

KNX Catalogue

Plan for intelligent Future Safety

Building Control Systems



Efficiency is the success factor in modern buildings



Contemporary building control has got to be easy and intelligent

Content

Presentation	4
Software	25
Overview power supplies	26
System components	27
Energy measurement	33
Interfaces/gateways	351
Wiser for KNX / spaceLYnk	36
U.motion	40
Visualization	54
Control and display devices	55
Access Control	58
Push-button	60
Binary inputs	80
Presence detectors and movement detectors	86
Other sensors	104
Switch actuators	114
Blind/switch actuators	134
Blind actuators	138
Dimming actuators/control units	144
DALI	153
Other actuators	156
Room temperature control units	157
Accessories	173
Index	174

Intelligent building
control simply
implemented!



KNX combines current requirements into one system

KNX is the intelligent building control system for all areas in which your customers live and work. From single-family houses to office complexes, the comprehensive portfolio of KNX solutions from Schneider Electric enables you to achieve flexible, energy-efficient, comfortable and safe solutions that are easy to plan, install and operate.



A KNX system grows with the customers' requirements

Comfort

Everyone nowadays expects more comfort and convenience in their domestic and working lives. What is called for are comfortable solutions that can be operated straightforwardly and without fuss, to make living and working easier.

Cost efficiency

Intelligent networking of all building systems can avoid unnecessary energy consumption and reduce operating costs on a sustained basis. The ability to expand modular KNX system technology ensures economical solutions that are guaranteed to remain tailor-made over the long haul.

Flexibility

In order to allow for flexible room usage over several decades, it is necessary for building functions to be adapted to the users' requirements easily in a cost-effective way – without the need for walls to be opened up and new cables to be laid.

Safety and security

To let residents feel as safe as possible, building technology must be able to react in a fast and intelligent way in any situation and at any time. No matter whether the building is full of life or quiet.

Combining building control with the technologies of the future



KNX combines modern building technologies in one system

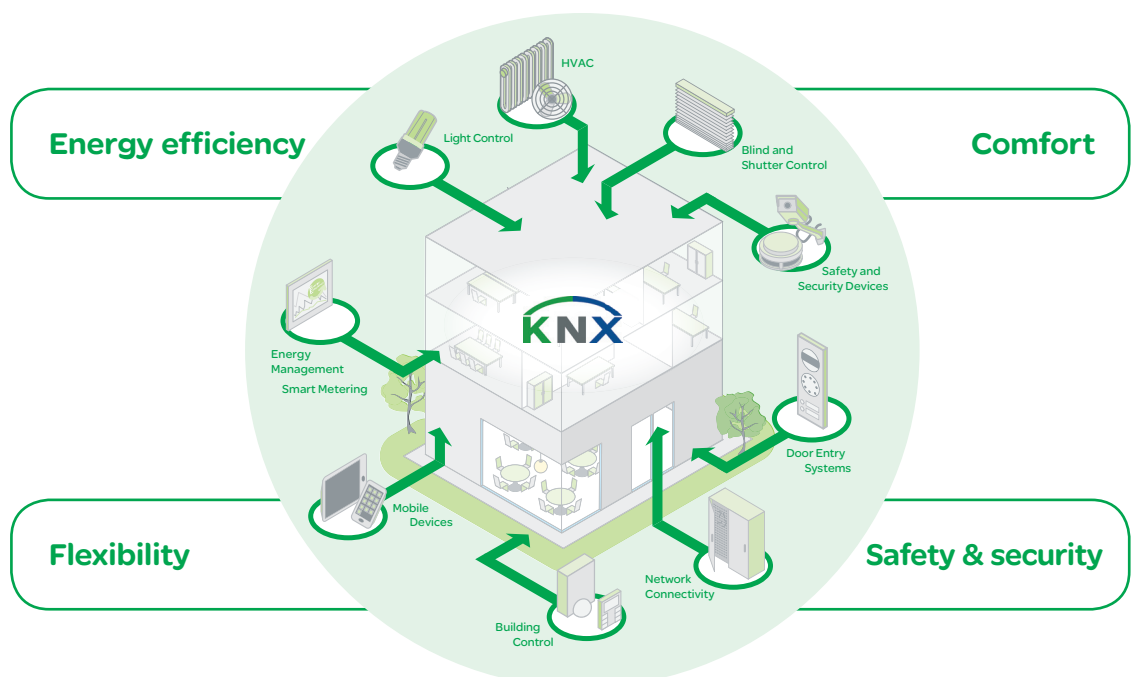



The advantages of modern building control with KNX

KNX offers convincing flexibility and cost efficiency. Whether in new buildings or for retrofitting, in private homes, offices, hotels or public buildings – KNX installations can easily be expanded and adapted again and again to new requirements.



The more extensive the application, the greater the efficiency

Low operating costs

KNX enables the operating costs of a building to be reduced in the long term by only activating loads such as air conditioning, heating and lighting when they are actually needed.

Control is effected automatically by means of time profiles as well as movement and presence detectors, thus leading to significant energy savings in offices and public buildings in particular.

Time savings

By networking all components via a single bus, it is possible to simplify the cable routing,

reduce the complexity of the wiring and make the system both clearly comprehensible and easy to expand. The Engineering Tool Software (ETS) makes the planning, installation and configuration of KNX easy, quick and efficient.

Flexibility and expandability

Changes of use are also effortless with KNX. The installation can be adapted to modified requirements or future developments at any time. Additional components can be integrated into the existing bus system without requiring further installation work.

Greater safety, security, comfort and efficiency in all building types

Comfort, safety and security in private homes

In private homes, the priority is on control convenience with high levels of safety and security. KNX conveniently connects different utilities together, realising comfortable solutions that are easy to operate and have intelligent functions for when the residents are not at home. Intelligent light and scene control provides the householders with a good feeling of safety and security – day and night.

Furthermore, the possibilities of KNX do not end at the boundaries of the property. Many functions can also be controlled from mobile devices or PCs by online access.

Flexibility and efficiency in offices and public buildings

Flexibility and cost efficiency are particularly important when it comes to commercial buildings. Due to their large number of differently used areas, offices and public buildings offer plenty of scope for significant energy-savings.

Automated building control can be perfectly adapted to the behaviour of users, and changed at any time in a straightforward procedure without any major expense.



Perfect working conditions

During everyday office activities, KNX solutions facilitate work and save energy – fully automatically. Adapting the lighting, heating and air conditioning to particular situations means that optimum working conditions can be achieved at any time. Unnecessary energy consumption is prevented by ensuring that loads are switched off automatically.



A KNX installation in the office raises the degree of comfort and transparency and saves energy at the same time

Open-plan office

Flexible lighting control

It is a normal situation in open-plan offices that employees do not leave their workplaces at the same time in the evening, but in dribs and drabs. Presence detectors over the desk clusters detect when areas are no longer being used, and then automatically deactivate the lighting. Constant lighting control ensures an ideal lighting situation from morning to evening.

Conference room

Presentation mode at the push of a button

With KNX, it is amazingly easy to prepare a presentation. At the push of a button, the lighting is dimmed in the entire conference room, the blinds and the presentation screen are lowered, the sound system and the beamer are activated, and the heating or air conditioning are set to the required temperature. And if the meeting turns out to be a long one, CO₂ sensors automatically activate the ventilation system.



spaceLYnk



ARGUS presence detector



KNX push-button plus with room temperature control unit



OptiLine



Secure living comfort

In the home, a modern KNX installation increases the quality of life by allowing everyday building functions to be controlled easily, more comfortably as well as more safely and cost-effectively with KNX.



KNX offers various control modes: manual, automatic, or mobile

Entrance area

Greater safety and security with central functions

It gives you a good feeling when you can see at a glance on leaving a building that everything is OK. A U.motion Touch Panel in the entrance hall provides an overview of the building status and allows central functions such as the "presence simulation" or "central off". Selected loads such as the lighting or appliances connected to socket-outlets can be integrated in functions of this kind. When the householders are absent, sensors detect storms or excessive sunlight and automatically activate awnings and blinds in the relevant areas as a protective measure.



U.motion Client Touch 10

Living room

Individual living comfort

Whether you plan to spend your evening playing games, watching TV or reading, or to have a cosy get-together with friends – every situation can be enhanced with an individual KNX scene. At the push of a single button, all required functions are activated at the same time: blinds are lowered, mood lighting is switched on and the room is heated or air-conditioned to just the right temperature. At the end of the evening, all functions can be switched off at the push of a button, thus putting the entire home into energy-saving night mode.



KNX push-button plus with room temperature control unit



Flush-mounted movement detector

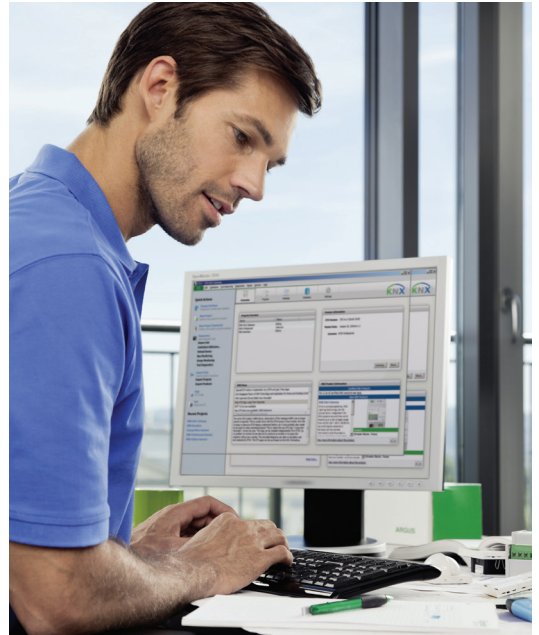

KNX – Technology with future

Systematic building control

As a global standard in building system technology, KNX offers unique advantages for all users. By intelligently linking together distributed system components via a bus system, it is possible to offer not only many more possibilities than in a conventional installation but also significant potential in the areas of energy efficiency, safety, security and comfort.



KNX guarantees that all components are compatible

Future-proof industry standard

KNX is the world's open standard for house and building system technology. In Europe, KNX is established in the EN 50491 and CEN EN 13321-1 and 13321-2 standards, and internationally by the ISO/IEC 14543-3 standard. In China, it corresponds to the GB/Z 20965 standard, and in the USA to the ANSI/ASHRAE 135 standard. KNX is thus a globally valid as well as applied standard. All KNX products from all manufacturers are certified by the KNX association. This means all components are guaranteed to be compatible and future-proof, across all manufacturers. The Engineering Tool Software (ETS) simplifies the tasks of project planning and commissioning of all KNX-certified products.

A successful system in figures

The total of around 300 members in 33 countries speaks for itself. At present, there are more

than 7,000 certified product groups, and about 70,000 projects have been implemented to date. This corresponds to more than 15 million installed KNX products. Today, there are already more than 30,000 ETS users who have been trained in one of the 150 training centres worldwide. Training and development of KNX are supported by 60 partners from the business and training establishments.

A strong partner for KNX solutions

Schneider Electric, the global specialist for energy-efficient solutions, offers a complete assortment of KNX products – from the strong design of the control interface through to all necessary DIN rail system components. All energy-saving solutions can be harmonised with one another in order to compose the right system for every need.



The intelligent bus principle

In conventional electrical installations, the control functions are mostly carried over the load cables. This means each function needs its own control cable. The intelligent solution is achieved by the installation bus which carries all the control signals in a building, thus making subsequent changes easy to implement.



Simply intelligent: an installation bus carries all control signals within a building

One bus for maximum flexibility

As part of a conventional electrical installation, it is necessary to specify how and where household systems are to be controlled prior to the building work. A KNX installation is flexible, because all functions can be changed and expanded at any time.

The two-wire installation bus routed in parallel to the 230 V electrical power supply connects all devices and systems of the household technology together, and transmits all the control signals. This is based on fast transmission rates with the highest levels of immunity to interference.

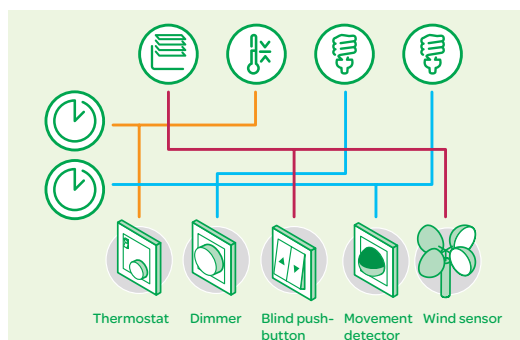

The conventional solution:
many separate lines, meaning less flexibility

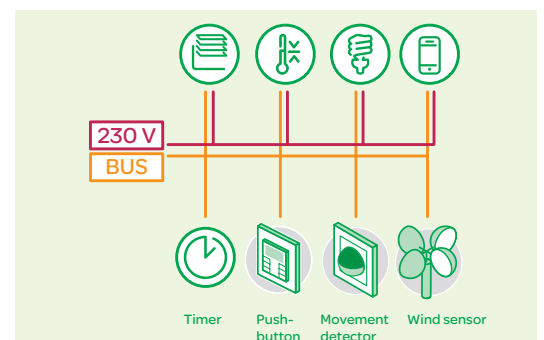

The intelligent KNX solution:
the bus carries out all control functions for maximum flexibility



The system components

All the devices for a KNX installation are connected together by a bus, thus allowing them to exchange data. The function of the individual bus devices is determined by their project planning, which can be changed and adapted at any time.



A KNX system is modular and flexible

System devices and components

They are needed for the fundamental functioning of the system. They consist of power supply units for generating bus voltage, couplers for connecting bus segments and interfaces for connecting programming devices.

Sensors

These are the starting point for every action, because they gather information and send it on the bus as a data telegram. This can be information about room temperatures, movements, wind measurements or manually input instructions.

Actuators

They receive data which are then converted into actions. This can include controlling blinds, dimming lights or controlling heating and air conditioning systems.

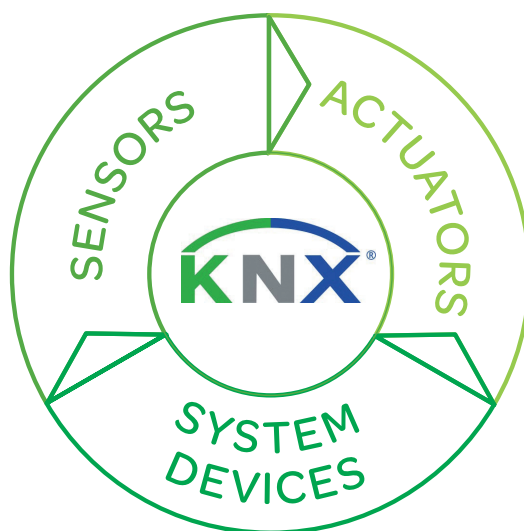



System devices (selection)



Power supply unit



KNX logic module



USB interface
REG-K



Line coupler



IP Router



Wiser for KNX

Sensors (selection)



KNX push-button



Movement detector



Room temperature
control unit



Binary input



Anemometer

Actuators (selection)



Switch actuator



Dimming actuator



Heating actuator

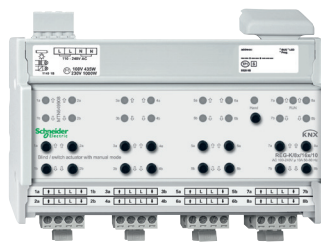

Blind actuator



KNX DALI-Gateway

Energy Efficiency with KNX and U.motion

Energy saving is not just a matter of conviction but is also a cost factor that puts money in your customers' pockets. U.motion offers the optimum basis for energy efficiency and can be expanded with additional components as required.



Energy Saving just by visualising consumption

Comprehensive energy management

Schneider Electric – leading supplier of energy management solutions – offers a large scope of energy solutions which can be perfectly combined with U.motion. And all of this is from a single source, so compatibility is assured.

LifeSpace Management is a comprehensive solution that you can adapt to each customer's individual situation.

Measuring and visualising – the first step to savings

Energy efficiency starts with the clear visualisation of all energy consumption values. Studies have shown that simply visualising energy consumption values prompts users to change their behaviour – with a potential saving of up to 10%!



U.motion Touch 10
Visualisation of Energy Consumption

Saving and evaluating energy data

The energy data can be measured and recorded, and then displayed as graphs. The longer the time frame of energy recording, the more precisely a building can be evaluated in terms of energy.

Devices with a high energy consumption can easily be identified, and their consumption can be immediately optimised via U.motion. Energy management with U.motion pays off – for you and for your customers.

Improvement starts with a decision about what to measure

The trump card of LifeSpace Management with U.motion is flexibility. For each requirement, Schneider Electric offers solutions for achieving individual energy efficiency concepts and energy

saving scenarios. The combination of switch actuators with current detection or KNX Energy Meter plus individually set switching times helps your customers to save energy.

Monitoring with high accuracy

The KNX Energy Meter provides energy measuring with class 1 accuracy for single and groups of devices. It measures total and period energy as well as instant power and provides 8 different alarm thresholds. When consumption exceeds preset limit, commands for switching or dimming can be sent or KNX scenes can be activated. The commands can be provided with adjustable delays if needed. Alarms can be sent to U.motion as well in case of current power, e.g. if server cooling falls below preset limits.



KNX and Modbus: an intelligent combination

The KNX Metering Gateway combines the expertise of the Modbus open standard with KNX intelligent building control. Measured values of up to 10 meters with a Modbus interface and connected SIM modules for recording gas and water consumption via impulse can be integrated into the KNX Energy Management, thus enabling comprehensive analysis of consumption.



Application Example

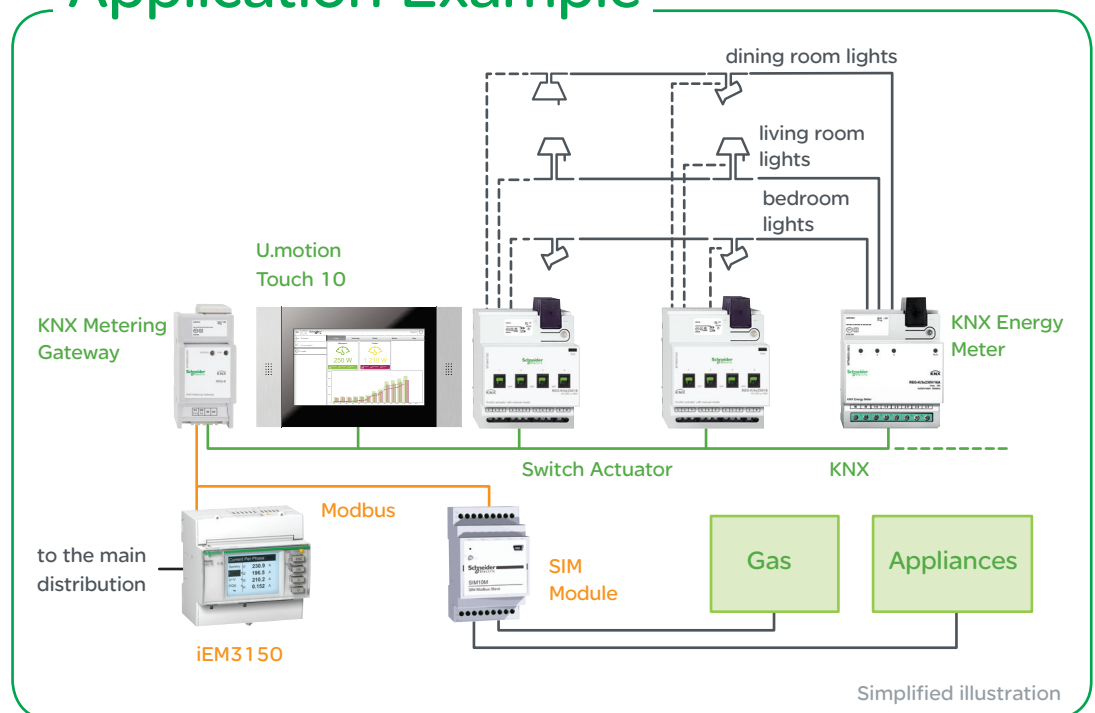

Become the building manager for your customers

Flexibility for today and tomorrow

There is a great desire for flexibility in both privately and commercially used properties alike. Demands change, and this has effects on the existing electrical installation. On such occasions in particular, it is good to be able to benefit from the advantages of flexible building control.



KNX configurations can be changed easily and inexpensively

Flexibility right from the start

Even during the planning of a new building, KNX offers the greatest possible flexibility for future room use. In this way, for example, meeting rooms can be designed for different forms of use – from conference through to presentation mode. It is easy to reconfigure individual KNX scenes, even when individual employees change locations.

Changing the use of rooms and floors

Whether a private home, an office complex or a hotel – the KNX structure can be adapted

and expanded in response to changes of use or modified partition positions without requiring new installation cables. This applies to retrofitting individual functions just as much as creating new central functions. Functional buildings with a KNX installation are especially attractive because it is easy to gear them up for new requirements; consequently, they remain straightforward to let or sell. Thanks to the comfortable configuration with ETS, it is quick, easy and inexpensive to make changes of function – from the single room to the entire office floor.





Profitability for your customers

Factors that are decisive for the cost efficiency of a KNX installation include the ongoing operational costs and, in particular, the investment costs, compared to conventional systems. The required range of functions is quite decisive in this case, because KNX will very quickly make itself pay if the functions go beyond those possible from a conventional solution.



With KNX, it is possible to save up to 30% operating costs in the long term

When it comes to a comparison between the investment costs of a KNX system and those of a conventional installation, what counts is the required range of functions. Often, even simple scene functions can be implemented more cost-effectively with KNX than on a conventional basis. One aspect to remember with regard to investment costs concerns the lower operating costs. As time goes by, building management requirements will change: private homes will be inhabited by several generations, rooms in commercial objects are put to different uses in their lifetime due to reorganisation or new tenants. Whereas a change of use or an expansion of a conventional installation is complicated and expensive, the flexibility of a KNX system pays off due to the minimum level of complexity. KNX opens the door to many possible savings in terms of a building's operating costs. From demand-related lighting control to energy management, the potential savings are determined by the depth of use.

Efficient and profitable for your customers

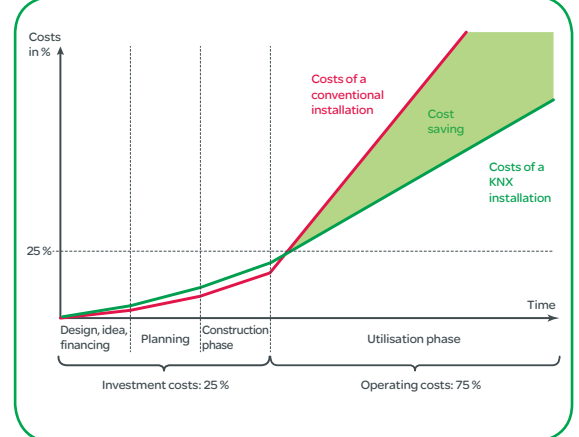



Intuitive user interfaces

The familiar KNX system devices, actuators and sensors are now complemented by the new KNX Multitouch Pro and KNX Push-button Pro – two new user interfaces that provide more functions and flexibility than a conventional range of multi-function push-buttons. They are also easy to install and commission, saving you valuable time.

In touch with comfort

The new KNX Multitouch Pro and Pushbutton Pro user interfaces are the perfect addition to modern KNX installations. They feature a high-quality design that sits perfectly flush in D-Life frames and an operating interface that has a similar look and feel to that of a smartphone or tablet. Incorporating innovative technology, this range delivers the ultimate in convenient operation and flexible control for room comfort functions.



KNX Multitouch Pro and
KNX Push-button Pro,
D-Life Metal, nickel metallic

KNX Multitouch Pro



The new KNX Multitouch Pro stands out thanks to its exceptional design. Its function control is similar to that of a smartphone or tablet. Swiping is used to achieve simple and intuitive switching between eight possible main functions. The unit offers a choice of two interface designs, vertical or rotary, which can also be

used in combination.

Special product features:

- Proximity sensor: Display illumination is activated automatically upon approach
- Gesture function: controls one previously defined function using a particular gesture
- Customizable screen saver

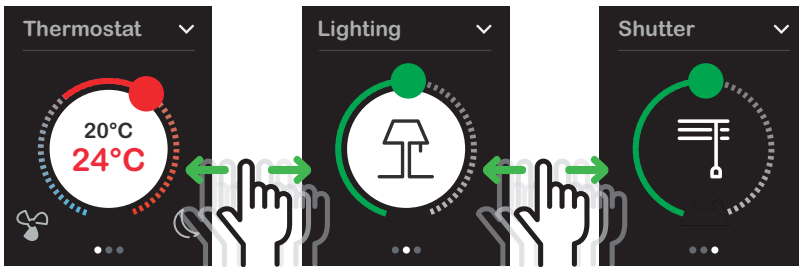

Swipe to switch between main functions

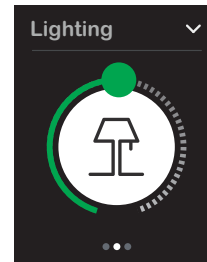

Lighting control – in rotary display mode
Uses a control-dial look and feel

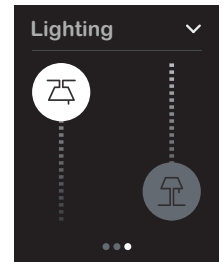

Lighting control – in vertical display mode
Enables control of two functions per display

KNX Push-button Pro



High-quality design and intuitive operability – the new KNX Push-button Pro concentrates on what is essential.

The individual touch-sensitive zones of the sensor cover are shown using illuminated function icons that shine through the translucent surface and emphasize the high-quality look of the new push-button.

The sensor cover is available in in all the System Design colors.

Up to four light, shutter and scenario functions can be controlled using the KNX Push-button Pro. This means that, in combination with the KNX Multitouch Pro, it offers the perfect solution for intuitive and flexible room control at home or in commercial spaces.

Customizable

The foil set included with the KNX Push-button Pro interface allows you to clearly and professionally label basic functions. A blank carrier foil can also be used to add individual symbols as required.

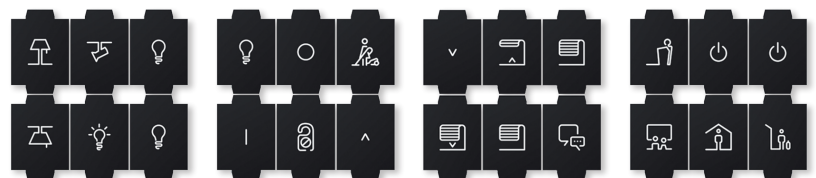

Individual symbols for use with carrier foil

Installation and commissioning

The new KNX user interface range offers a completely new approach to planning, commissioning and installation. Simpler, faster and more flexible.

Features that you and your customers will love

In the past, all KNX functions had to be pre-defined before installation. Now the new KNX user interface makes planning simpler. Only two references are required for a simple KNX installation in all rooms, based on the number of required functions. The allocation of desired functions can be implemented at the time of commissioning.

An express commissioning feature enables rapid project design. Frequently used functions are pre-defined in the ETS application. The allocation of desired functions can be modified at any time with no risk of losing group addresses. The KNX Multitouch Pro and KNX Push-button Pro do not require an additional power supply.

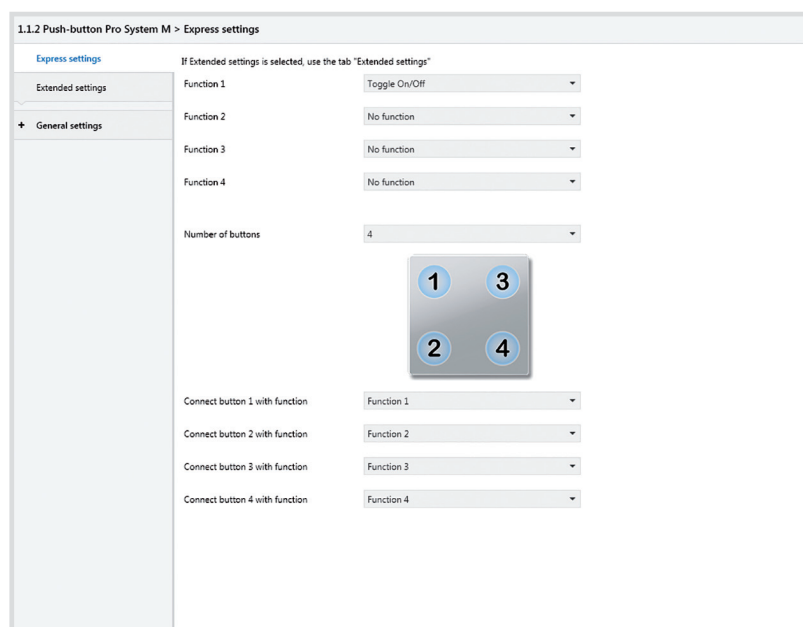

ETS express settings for the KNX Push-button Pro.

Flexible in every detail

At Schneider Electric, comfort, safety, security and flexibility are combined with an extensive variety in design and function. Customers' wishes can be met easily, from the movement detector to the touch panel.

Example: Merten System M



KNX push-buttons



KNX push-button 4-gang plus with room temperature control unit



KNX push-button 2-gang plus with room temperature control unit



KNX push-button 1-gang plus



KNX push-button 2-gang plus



KNX push-button 4-gang plus



KNX push-button 4-gang plus with IR receiver



Push-button modules



Push-button 1-gang



Push-button with 1/0 imprint 1-gang



Push-button 2-gang



Push-button with 1/0 imprint and up/down arrows 2-gang



KNX Movement and presence detectors



KNX ARGUS movement detector 180, flush-mounted



KNX ARGUS movement detector 180/2.20, flush-mounted



KNX ARGUS presence detector, flush-mounted

Example: Unica



KNX push-buttons



KNX push-button



KNX push-button with
IR receiver



KNX push-button,
2-gang



KNX room temperature
control unit



KNX Movement and
presence detectors



KNX movement detector

Example: Altira



KNX push-buttons



KNX push-button



KNX push-button with
IR receiver



KNX push-button,
2-gang



KNX room temperature
control unit



KNX Movement and
presence detectors



KNX movement detector

Innovations

U.motion LifeSpace Management



U.motion combines simplicity, flexibility and energy efficiency

Bringing spaces to life

U.motion is an open, maximally compatible system for KNX building control that provide every individual function from a single source. From a basic installation through a large server solution with numerous Touch Panels – U.motion is freely scalable. The Touch Panels are available in three different sizes: with 7", 10" and 15" screen as well as a special version of the U.motion KNX Server Plus integrated in an U.motion Touch Panel 10" or 15".



U.motion KNX Server



Adapt to requirements while keeping the right price

Two versions available

The U.motion KNX Server is the entry point to the U.motion solution and is an ideal option for those cases where Apps and mobile devices or 7" Touch Panels will be used for visualisation and control. Where a high-performance solution is required, the U.motion KNX Server Plus allows for establishing more complex systems that integrate the larger Touch Panel versions or integration of Door Entry systems.



U.motion Apps



Scan the QR-Code to discover more about U.motion

100% mobile

The U.motion Interface is standardised on all control devices. Whether you use a Touch Panel, smartphone or tablet, you always use the same interface. This makes U.motion even more comfortable. The U.motion Control App and the Communication App are fully free of charge and can be downloaded for free.



Innovations

InSideControl



Available on the common platforms

Upgrade KNX to the next comfort level

Whether in a private home or small office buildings, as part of a new installation or when retrofitting existing KNX installations: Schneider Electric InSideControl easily turns smartphones and tablets into remote controls for building functions. Controlling lights and temperature, calling up scenes or visualizing the energy consumption are just a few of the possibilities the app comes up with.



KNX Energy Meter



Easy visualisation

High precision for low consumption

The KNX Energy Meter from Schneider Electric allows for measuring the energy consumption of individual devices or groups of devices. Individual energy-saving functions can be programmed, such as dimming, switching and retrieving scenes, as can alarms for specific threshold values. This actively helps to save energy.

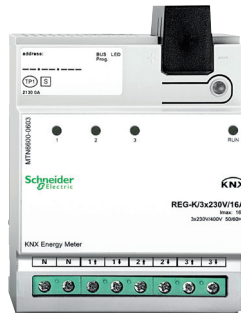

Wiser for KNX | spaceLYnk



Wiser for KNX and spaceLYnk are ready to communicate with several protocols

KNX home automation Building automation

Schneider Electric offers two new logic controllers for home and building automation, connecting different standards and protocols to increase comfort and allow energy monitoring. Each is optimised for a certain building type:

- Wiser for KNX for home automation
- spaceLYnk for building automation.



Software

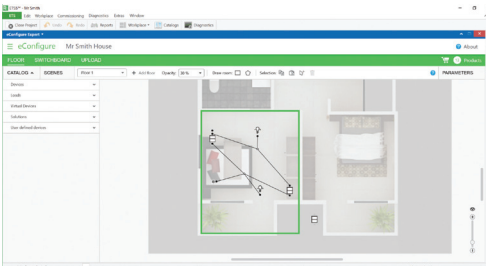
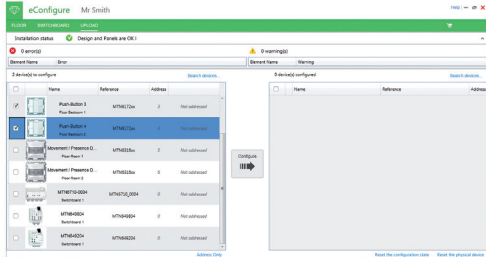
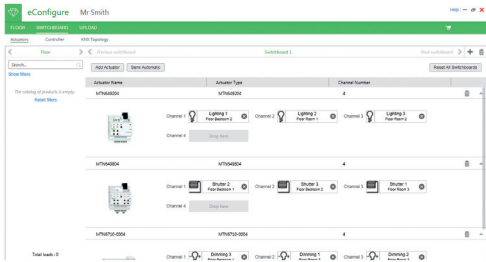

eConfigure KNX Lite



Version	Art. no.
Lite	LSS900100 New

“eConfigure KNX Lite” is a graphical tool for seamless configuration and set-up of a home & building automation solutions.

The user creates his installation graphically directly on the plans of his installation and determines the functions of each KNX sensors (pushbuttons, thermostats, detectors, ...) in a simple, fast and intuitive way. KNX products in switchboards are generated automatically, which allows the user to save time, while being assured of a functional installation.

A library of solutions can be integrated in the software, allowing the novice or experienced user who wants to optimize his time to quickly create his project. It is also possible for the user to create his own solutions.

An installation report and list of products (bill of materials) can also be edited to allow the user to build a complete and professional file for the rest of his team or for his own clients.

Compatible operating system: Windows 7 SP1, Windows 8, Windows 10

Minimum computer requirements: Refer to user manual.

List of compatible KNX products: Refer to user manual

Note: This software must be installed on a computer using the Windows® operating system.

Contents: Box with KNX Dongle and USB stick containing software.

eConfigure KNX Expert

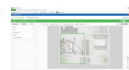

Version	Art. no.
Expert	Available on knx.org shop New (ETS App)

‘eConfigure KNX Expert’ is a graphical ETS App for seamless configuration and set-up of a home & building automation solutions.

The user creates his installation graphically directly on the plans of his installation and determines the functions of each KNX sensors (pushbuttons, thermostats, detectors, ...) in a simple, fast and intuitive way. KNX products in switchboards are generated automatically, which allows the user to save time, while being assured of a functional installation.

A library of solutions can be integrated in the software, allowing the novice or experienced user who wants to optimize his time to quickly create his project. It is also possible for the user to create his own solutions.

An installation report and list of products (bill of materials) can also be edited to allow the user to build a complete and professional file for the rest of his team or for his own clients.

All projects done with the Lite version are compatible with the Expert version. It is possible to export the complete project in ETS.

Compatible operating system: Windows 7 SP1, Windows 8, Windows 10



Minimum computer requirements: Refer to user manual.

List of compatible KNX products: Refer to user manual

Note: ETS5 with Pro license shall be used..

KNX

Overview power supplies

	KNX power supply REG-K			KNX power supply REG-K with emergency power input		
						
Article number	MTN684032	MTN684064		MTN683832	MTN683890	
Output current	320 mA	640 mA		320 mA	640 mA	
Maximum number of bus devices	64	64		64	64	
Input voltage, 50-60 Hz	AC 110-230 V			AC 110-230 V		
Output voltage	DC 30 V			DC 30 V		
Device width	4 modules			4 modules		
Connections and displays						
LED display for maximum current		■			■	
Reset switch		■			■	
Connection for emergency power supply art. no. MTN683901		—			■	

Bus voltage supply



The current product database can be obtained from the Internet at <http://www.schneider-electric.com> or PI@net.

KNX power supply REG-K/320 mA



Version	Art. no.
light grey	MTN684032

For generating the bus voltage for a line with up to 64 bus devices.
 With integrated choke to decouple the power supply from the bus and a push-button to disconnect the power and reset the bus devices connected to the line.
 For installation on DIN rails TH35 according to EN 60715. The bus is connected using a bus connecting terminal; a data rail is not necessary.
Nominal voltage: AC 110-230 V $\pm 10\%$
Operating voltage: min. AC 92 V - max. AC 253 V
Mains frequency: 50-60 Hz $\pm 10\%$
Output voltage: DC 30 V
Output current: max. 320 mA, short-circuit-proof
Device width: 4 TE = approx. 72 mm
Contents: With bus connecting terminal and cable cover.

KNX power supply REG-K/320 mA with emergency power input



Version	Art. no.
light grey	MTN683832

For generating the bus voltage for a line with up to 64 bus devices. The emergency power supply REG can be connected in order to buffer the bus voltage.
 With integrated choke to decouple the power supply from the bus and a push-button to disconnect the power and reset the bus devices connected to the line.
 For installation on DIN rails TH35 according to EN 60715. The bus is connected using a bus connecting terminal; a data rail is not necessary.
Nominal voltage: AC 110-230 V $\pm 10\%$
Operating voltage: min. AC 92 V - max. AC 253 V
Mains frequency: 50-60 Hz $\pm 10\%$
Output voltage: DC 30 V
Output current: max. 320 mA, short-circuit-proof
Device width: 4 TE = approx. 72 mm
Accessories: REG emergency power supply MTN683901
Contents: With bus connecting terminal and cable cover.

System components



KNX power supply REG-K/640 mA		KNX power supply REG-K/640 mA with emergency power input	
Version	Art. no.	Version	Art. no.
light grey	MTN684064	light grey	MTN683890
<p>For generating the bus voltage for a line with up to 64 bus devices. With integrated choke to decouple the power supply from the bus and a push-button to disconnect the power and reset the bus devices connected to the line. For installation on DIN rails TH35 according to EN 60715. The bus is connected using a bus connecting terminal; a data rail is not necessary. Nominal voltage: AC 110-230 V ±10% Operating voltage: min. AC 92 V - max. AC 253 V Mains frequency: 50-60 Hz ±10% Output voltage: DC 30 V Output current: max. 640 mA, short-circuit-proof Device width: 4 TE = approx. 72 mm Contents: With bus connecting terminal and cable cover.</p>		<p>For generating the bus voltage for a line with up to 64 bus devices. The emergency power supply REG can be connected in order to buffer the bus voltage. With integrated choke to decouple the power supply from the bus and a push-button to disconnect the power and reset the bus devices connected to the line. For installation on DIN rails TH35 according to EN 60715. The bus is connected using a bus connecting terminal; a data rail is not necessary. Nominal voltage: AC 110-230 V ±10% Operating voltage: min. AC 92 V - max. AC 253 V Mains frequency: 50-60 Hz ±10% Output voltage: DC 30 V Output current: max. 640 mA, short-circuit-proof Device width: 4 TE = approx. 72 mm Accessories: REG emergency power supply MTN683901 Contents: With bus connecting terminal and cable cover.</p>	

System components



REG emergency power supply



Version	Art. no.
light grey	MTN683901

To buffer the bus voltage. If a complete mains failure occurs, an external lead gel battery with a voltage of DC 12 V (SELV) can be connected to the REG power supply for buffering. The lead gel battery is recharged or maintained in its charged state by integrated charging electronics.

A binary input can be connected in order to register the operational statuses (mains voltage, error warning, battery operation).

For installation on DIN rails TH35 according to EN 60715. A data rail is not necessary.

Nominal voltage: AC 110-230 V ±10%

Operating voltage: min. AC 92 V - max. AC 253 V

Mains frequency: 50-60 Hz ±10%

Output to power supply:

Output voltage: DC 30 V ±2 V

Output current: without battery with mains supply max. 300 mA, with battery without mains supply max. 640 mA

Buffer time with lead gel battery 7,2 Ah:

683890: approx. 0.5 h

683832: approx. 1 h

683816: approx. 2 h

Buffer time with lead gel battery 18 Ah:

683890: approx. 1.25 h

683832: approx. 2.5 h

683816: approx. 5 h

Short-circuit current: < 1.5 A

Charging current: max. 1 A

Connections: plug-in screw terminal for main connector, operating state (4-pin, 3 floating contacts) and emergency power supply. Plug-in terminal for battery connection (two 1 mm pins)

Device width: 4 modules = approx. 72 mm

In KNX, to be completed with: KNX power supply REG-K/160 mA with emergency power input MTN683816

KNX power supply REG-K/320 mA with emergency power input MTN683832

KNX power supply REG-K/640 mA with emergency power input MTN683890

Accessories: Lead gel battery MTN668990

MTN668991

Binary input REG-K/4x24 MTN644892

Spannungsversorgung REG, DC 24 V/0,4 A MTN693003

Contents: With connecting terminal and cable cover



Lead gel battery



Version	Art. no.
7.2 Ah	MTN668990

Lead gel battery to connect to the emergency input of the power supply 320 REG-K with battery connection.

Nominal voltage: DC 12 V

Capacity: 7.2 Ah

In KNX, to be completed with: REG emergency power supply MTN683901

Lead gel battery



Version	Art. no.
	MTN668991

Lead gel battery for connecting to the emergency power supply REG.

Nominal voltage: DC 12 V

Capacity: 18 Ah

In KNX, to be completed with: REG emergency power supply MTN683901

System coupler



Coupler REG-K



Version	Art. no.
light grey	MTN680204

For logical connection and electrical isolation of lines and areas.
For installation on DIN rails TH35 according to EN 60715. The bus is connected using a bus connecting terminal; a data rail is not necessary.

KNX software functions: The device can be used as a backbone / line coupler or as a repeater for forming line segments in existing or new KNX systems. The function as a coupler or repeater can be parameterised.

Functions as coupler

Use as a backbone or line coupler depending on the physical address. Reduction of the bus load through the filter function (filter table). Support of the full address area (Group 0-31) with filter function. Forwarding of physically addressed telegrams (line => main line, main line => line) can be parameterised. Forwarding of group telegrams (line => main line, main line => line) can be parameterised. Telegram repetitions in the event of transmission errors can be set separately for group telegrams, broadcast telegrams and physically addressed telegrams. Telegram confirmation for group telegrams and physically addressed telegrams can be parameterised separately.

Functions as repeater

Expansion of a line to max. 4 line segments with up to 64 participants each (incl. line coupler or repeater). Telegram repetitions in the event of transmission errors can be set separately for group telegrams, broadcast telegrams and physically addressed telegrams. With repeaters, the telegrams are always forwarded.

Device width: 2 modules = approx. 36 mm

Note: With the coupler/repeater 7116/1.1 application, the entire group address range from 0 to 31 can be used for the filter function of the coupler (support for extended group addresses). This application requires ETS 4.1 or higher.

Contents: With 2 bus connecting terminals.



KNX/IP router REG-K



Version	Art. no.
light grey	MTN680329

The KNX/IP router enables telegrams to be forwarded between different lines via LAN (IP) as a rapid backbone. The device can additionally serve as a programming interface in order to connect a PC with the KNX bus (e.g. for ETS programming with suitable ETS).

The IP address can be assigned dynamically via a DHCP server or via manual configuration (ETS parameter). The device operates in accordance with the KNXnet/IP specification using Core, device management, tunnelling and routing.

The KNX/IP router forwards telegrams in both directions whilst taking a filter table into account and can buffer up to 150 telegrams.

For installation on DIN rails TH35 according to EN 60715. The bus is connected using a bus connecting terminal; a data rail is not necessary.

Supply voltage: DC 12-30 V (at DC 24 V 40 mA), AC 12-24 V

Device width: 2 modules = approx. 36 mm

In KNX, to be completed with: Spannungsversorgung REG, DC 24 V/0,4 A MTN693003
Power supply REG, AC 24 V/1 A MTN663529



Also alternatively Power over Ethernet (PoE).

Note: With version 0C and higher, a total of up to 5 simultaneous connections is supported.

Contents: With bus connecting terminal.

System accessories



Bus connecting terminal		Branch terminal, yellow/white	
			
Version	Art. no.	Version	Art. no.
red/dark grey	MTN689701	yellow/white	MTN689702
<p>For connecting max. 4 core pairs to an KNX device, can also be used as a branch terminal. Consists of two interlocked terminal parts in red ("+") and dark grey ("-"), each with 4 plug-in terminals. For solid conductors with a diameter of 0.6 to 0.8 mm. Contents: 1 PU = 50 terminals.</p>		<p>Branch terminal comprising two interlocking terminal parts in yellow and white, each with 4 plug-in terminals. For solid conductors with a diameter of 0.6 to 0.8 mm. For wiring the yellow/white cores of the bus cable. Contents: 1 PU = 50 terminals.</p>	

IR universal remote control



Version	Art. no.
black/white	MTN5761-0000
<p>10 channel IR remote control. For the control of all TELE sensor covers, blind push-buttons with IR receiver, presence detectors with IR receivers and KNX devices with IR receivers. Battery: 2 microcells (IEC LR 0.3 AAA) (not included) Range: up to 12 m Receiver: TELE sensor cover System M MTN5779.., MTN5703.. Blind push-button with IR receiver and sensor connection System M MTN5880.., MTN5864.. ARGUS Presence Master with IR, relay 1-gang MTN5510-1119 ARGUS Presence Master with IR, relay 2-gang MTN5510-1219 ARGUS Presence Master with IR, 1-10 V MTN5510-1419 ARGUS Presence Master with IR, DALI MTN5510-1519 KNX ARGUS Presence with light control and IR receiver MTN6309.. Push-button, 4-gang plus with IR receiver System M MTN6279.., MTN6175.. KNX 1-gang push-button with IR receiver Altira ALB4x152 Unica MGU3.532.18, MGU3.532.25 Unica Top MGU3.532.12, MGU3.532.30 Unica MGU5.532.18, MGU5.532.25 Unica Top MGU5.532.12, MGU5.532.30 Push-button 4-gang plus with room temperature control unit System M MTN6214-03.. /-04.. Contents: Without battery.</p>	

Logic module



KNX Logic module Basic REG-K



Version	Art. no.
light grey	MTN676090

In KNX installations, the logic module serves as a logic and control device. It has 10 logic, 10 filter/timer, 8 converter and 12 multiplexer modules.

With 3 freely programmable push-buttons and 3 status LEDs. They can be assigned control and test functions and can be operated on the device.

For installation on DIN rails TH35 according to EN 60715. The bus is connected using a bus connecting terminal; a data rail is not necessary.

KNX software functions:

10 logic modules (AND, OR, XOR)

- Each with up to 8 binary input objects and an output object.
- Input and output object inversion.
- Output disable via gate function.
- Behaviour of each input object after bus reset.
- Adjustable sending behaviour.

10 filter and timer modules

- Binary input objects and an output object with time delays.
- Binary input object filtering before output.
- Output disable via gate function.
- Behaviour of each input object after bus reset.
- Adjustable sending behaviour.

8 converter modules

- Conversion of 1 bit switching telegrams into 2 bit priority control.
- Conversion of 1 bit switching telegrams into 8 bit value telegrams.
- Conversion of 8 bit value telegrams into 1 bit switching telegrams.
- Output disable via gate function.
- Behaviour of each input object after bus reset.
- Adjustable sending behaviour.

12 multiplexer modules (lighting control)

Multiplexer modules are used to selectively control telegrams, e.g. to toggle between single room and total room control for conference rooms with partition walls.

- Supported telegram formats by module: 1 bit, 2 bit, 4 bit, 8 bit, 2 byte.
- A module can be used for the 4 byte format.
- Telegram forwarding/blocking in one or both directions using the control object.
- Adjustable gate behaviour.
- Adjustable control object behaviour.
- Output disable via gate function.
- Adjustable sending behaviour.
- Adjustable sending delay.

Push-button and LED assignment

- The three push-buttons and the three LEDs can be freely assigned with binary objects.
- Behaviour per LED.
- Behaviour per push-button.

Behaviour after bus reset

- Adjustable module start-up delay after bus voltage recovery.

Device width: 2.5 module = approx. 45 mm

Energy measurement



KNX Energy Meter, REG-K/3x230 V/16 A



Version	Art. no.
light grey	MTN6600-0603

Device for measuring and monitoring energy consumption at up to three channels. Different phases can be connected to the channels. The data is transmitted to the KNX bus for analysis and visualisation.

There is a resettable energy counter and a total energy counter for each channel. The device saves the values in the event of a power failure. If one of up to 8 threshold values is exceeded, telegrams for energy-saving and alarm functions can be sent to different loads via the bus. The energy meter can receive energy values measured externally (e.g. from other energy meters or switch actuators with current detection) via the KNX bus and summate them. With screw terminals.

Suitable for installation on DIN rails TH35 according to EN 60715.

KNX software functions: Functions per channel:

Adjustable energy unit (Wh/kWh). Energy meter (resettable). Total energy meter. Adjustable transmission of power and current values.

Energy-saving function: telegrams for saving energy (switch object, value object, dimming object, scene object and temperature object) are sent when one of up to 8 threshold values is exceeded. 8 separately adjustable threshold values with tolerance (selectable via object).

Adjustable tolerances and delays.

Alarm function: alarms are sent when current values fall above or below threshold values.

Adjustable tolerances and delays.

Functions for all channels:

Consumption values with time stamp. Time can be received via an external KNX timer.

Adjustable nominal voltage (210-240 V). 4 energy counters to count separately depending on tariff. Summation of energy values from several channels and external energy values. Status responses regarding bus voltage failure, exceedance of power, total power and tariff meters.

Energy measurement:

Number of channels: 3

Nominal voltage: AC 220/230 V, 50/60 Hz

Max. current per channel: 16 A

Min. current per channel: 20 mA (power factor 1)

Detection accuracy:

Power and current measurement (calculated): max. 10 %

Capacity of total power meter: > 2 million kWh

Temperature range: -5°C to + 45°C

Type of protection: IP 20

Device width: 4 modules = approx. 72 mm



KNX Metering Gateway Modbus REG-K



Version	Art. no.
light grey	MTN6503-0201

The KNX Metering Gateway Modbus REG-K is a gateway between a Modbus installation and the KNX bus.

The device transmits measured power and consumption values from connected Modbus power counters to the KNX bus. These power counter data can be used to evaluate, visualise, or reduce the power consumption in your KNX installation.

Up to ten Modbus counters can be connected to the gateway in parallel with RTU transfer protocol. These counters send data to the KNX via the gateway. The gateway always works in master mode, and the connected Modbus devices work in slave mode. Communication from KNX to the Modbus is not possible. The ETS application has pre-programmed templates for 17 different Schneider Electric models of Modbus counters. In ETS, a corresponding template can be assigned to each connected Modbus counter. The corresponding Modbus registers are then automatically assigned to the communication objects on the KNX side.

The following models of Schneider Electric Modbus counters are supported:

- PM9C universal meter
- PM210 universal meter
- PM710, PM750 universal meters
- PM810, PM820, PM850, PM870 universal meters
- PM1200, PM6200 universal meters
- iEM3150, iEM3155, iEM3250, iEM3255 energy counters
- PM3250, PM3255 universal meters
- SIM10M Smart Interface Module

For Modbus devices without a template, up to 40 Modbus registers can be directly assigned to the communication objects on the KNX side.

The device is supplied with power via the KNX bus.

With integrated bus coupler. For installation on DIN rails TH35 according to EN 60715. The bus is connected using a bus connecting terminal.

With screw terminals.

KNX software functions: Modbus communication settings (baud rate, parity, delays). Selection of pre-programmed templates for 17 Modbus counters with detection of: voltage (phase 1-3), current (phase 1-3), frequency, power factor, active power, reactive power, apparent power, active energy, reactive energy, 6 binary counters, 2 analogue inputs (using Smart Interface Module SIM10M template). In addition to the template, direct access to Modbus registers and manual assignment of the register values to communication objects are possible. Diagnostic function: active and passive evaluation of errors in the Modbus installation. All values can be reset by a reset object.

Device width: 2.5 modules = approx. 44 mm

Data interfaces



Central plate with square opening



Version	Art. no.
<input checked="" type="checkbox"/> white, glossy	MTN296044
<input type="checkbox"/> polar white, glossy	MTN296019
<input type="checkbox"/> active white, glossy	MTN296025
<input checked="" type="checkbox"/> anthracite	MTN297914
<input type="checkbox"/> aluminium	MTN297960

For System M.
for loudspeaker connection inserts or flush-mounted USB interface.
To be completed with: Telephone socket-outlet TAE, 1-gang MTN465206, Telephone socket-outlet TAE, 3-gang MTN465226/36, Combination socket-outlet RJ45/TAE (Cat 3) MTN465707, Loudspeaker connection insert, 1-gang MTN466919/14, Loudspeaker connection insert, 2-gang MTN467019/14, USB power supply MTN4366-0000, USB interface, flush-mounted MTN681799

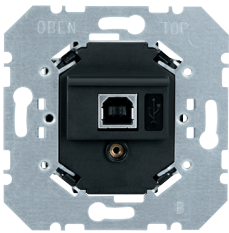

USB interface, flush-mounted



Version	Art. no.
	MTN681799

For connecting a programming or diagnostics device with a USB1.1 or USB2 interface to the KNX.
For screw mounting in the size 60 installation box. With integrated bus coupler. The device is connected to the bus with a bus connecting terminal. Compatible with ETS 3.
Mounting depth: 20 mm
To be completed with: Central plate with square opening System M
Contents: With bus connecting terminal.



USB interface REG-K



Version	Art. no.
light grey	MTN681829

For connecting a programming or diagnostics device with a USB1.1 or USB2 interface to the KNX.
With integrated bus coupler. For installation on DIN rails TH35 according to EN 60715. The bus is connected using a bus connecting terminal; a data rail is not necessary.
Device width: 2 modules = approx. 36 mm
Contents: With bus connecting terminal and cable cover.

Wiser for KNX

KNX home automation

Wiser for KNX is the perfect choice for houses, collective homes and flats. With 150 BACnet points it is perfectly suitable for an integration in a large building management system of the complete residential building.

Wiser for KNX connects KNX systems and Modbus meters, which conveniently allows control of building functions like lights, shutters and heating and enables energy monitoring with record data

on a daily, monthly and yearly basis. Wiser for KNX enables to create advanced logic functions in order to optimize energy efficiency and comfort at home.



Wiser for KNX
is perfectly set for residential buildings

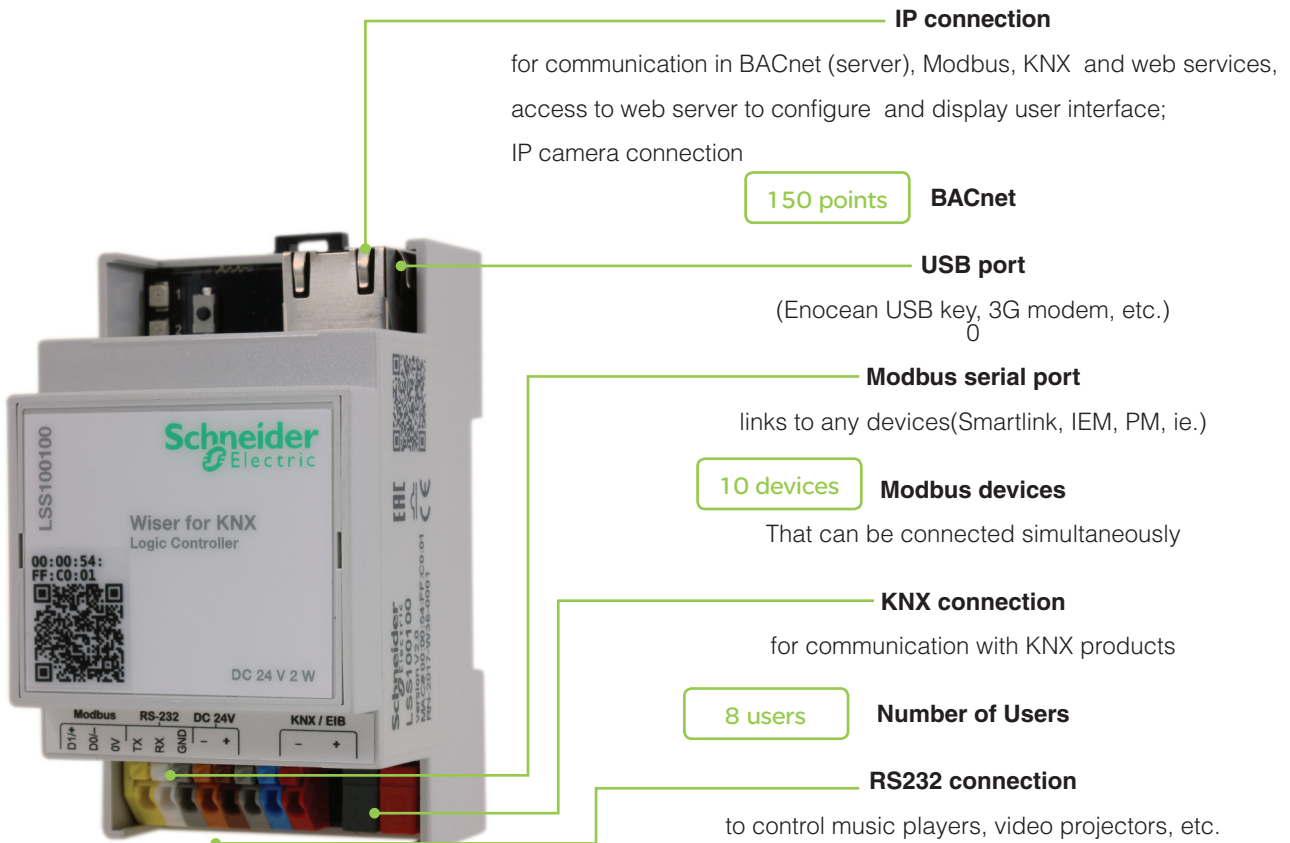
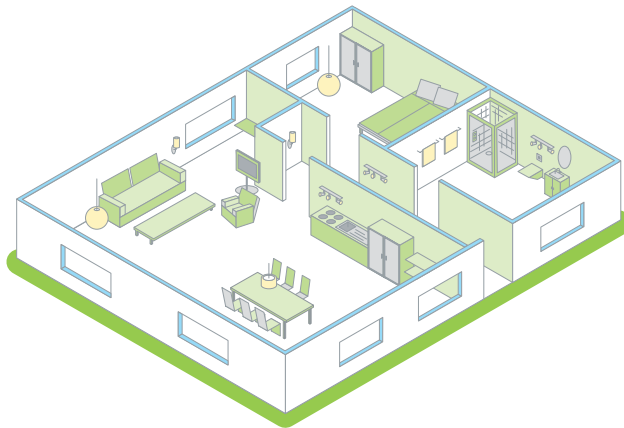

Wiser for KNX



Solutions are tested and validated according to Schneider Electric process

Wiser for KNX



Version	Art. no.
	LSS100100

Logic Controller
 Wiser for KNX is the easiest way to visualise and control a complete Home Automation Solution in a KNX and Modbus networks.

- Wiser for KNX (formerly know as homeLYnk) can be used in several ways:
- As an user interface to display and control relevant informations on mobile devices
 - As a gateway to translate and enable communication between different products
 - As an aggregator to stock, analyze, and send the data (.csv file for example)
 - As an event controller that sends email in case of issues

Applications:

- Logical functions
- WEB SCADA visualization for PC and touch-devices
- Cross-standard gateway between KNX and Modbus RTU/TCP
- BACnet Server (150 points)
- Integration with third party devices over RS-232 (IR, AV)
- Scheduling
- Camera streaming
- Data logger with trends
- Pre-made Modbus templates
- Easy bloc programming
- Up to 8 users with different login and password
- BACnet certified "BACnet Application Specific Controller (B-ASC)"
- New icons

Supply voltage: 24 V DC

Power consumption: 2 W

LED indicator 1: Green LED (CPU load)

LED indicator 2: Green LED (Operation) or Red LED (Reset)

Interface: 1x KNX, 1x10BaseT/100BaseTX, 1x RS-485 (incl. Polarization resistors 47 kΩ, no termination), 1x RS-232, 1x USB2.0, 1x Reset push button

Terminal:

KNX bus: Bus connecting terminal 2 x 0.8 mm

Power supply: Clamp, 0.5 mm²–1.5 mm²

Serial: Clamp, 0.5 mm²–1.5 mm²

Operation: -5°C to +45°C

Environment: Can be used at elevations up to 2000 m above sea level (MSL)

Max. humidity: 93 %, no condensation

Dimension: 90 x 52 x 58 mm (HxWxD)

Device width: 3 modules = approx. 54 mm

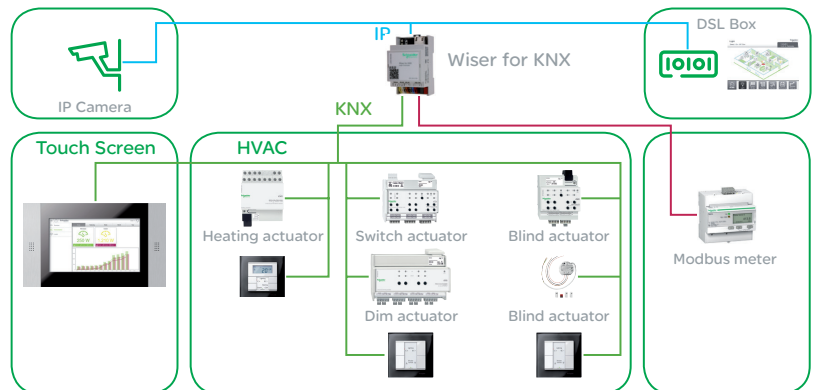

In buildings spaceLYnk provides the ideal solution. Thanks to 500 BACnet points spaceLYnk can easily be integrated into complete building management systems.

spaceLYnk allows efficient facility management thanks to the convenient web-based user interface with maintenance information like lamp statuses

and easy scheduling of all building functions. The webbased interface is accessible from everywhere, enabling remote maintenance.



spaceLYnk is perfectly set for commercial buildings

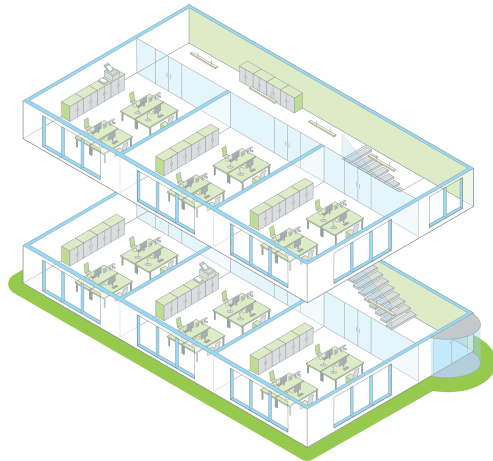

IP connection — for communication in BACnet (server), Modbus, KNX and web services, access to web server to configure and display user interface; IP camera connection

BACnet 500 points

USB port — (EnOcean USB key, 3G modem, etc.)

Modbus serial port — links to any devices(Smartlink, IEM, PM, ie.)

Modbus devices 31 devices

That can be connected simultaneously

KNX connection — for communication with KNX products

Number of Users 50 users

RS232 connection — to control music players, video projectors, etc.

IP/TP KNX filtering Available

Quick IP/TP KNX filtering on object tab



spaceLYnk

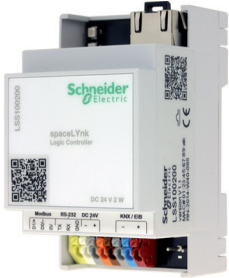

Solutions are tested and validated according to Schneider Electric process

spaceLYnk



Version

Art. no.

LSS100200

Logic Controller

spaceLYnk is the easiest way to build a complete Building Automation Solutions for commercial segments :

- Complete Building Automation solution for Small and Medium building with a complete architecture including Light and Room Control (KNX, DALI Control), Metering (Modbus offer, Smartlink RTU and IP), and boiler management (SSL)
- Complete Building Automation solution for Large Building with a complete architecture managed by SBO (BMS from Schneider Electric) and including Light and Room Control (KNX, DALI Control) and Metering (Modbus offer, Smartlink RTU and IP)

spaceLYnk can be used in several ways:

- As a gateway to translate and enable communication between different products
- As an aggregator to stock, analyze, and send the data (.csv file for example)
- As an user interface to display relevant informations on mobile devices
- As an event controller that sends email in case of issues

Applications:

- Logical functions
- WEB SCADA visualization for PC and touch-devices
- Cross-standard gateway between KNX and Modbus RTU/TCP
- BACnet Server (500 points)
- Integration with third party devices over RS-232 (IR, AV)
- Scheduling
- Camera streaming
- Data logger with trends
- Pre-made Modbus templates
- Easy bloc programming
- Up to 50 users with different login and password
- BACnet certified "BACnet Application Specific Controller (B-ASC)"
- New icons

Supply voltage: 24 V DC

Power consumption: 2 W

LED indicator 1: Green LED (CPU load)

LED indicator 2: Green LED (Operation) or Red LED (Reset)

Interface: 1x KNX, 1x10BaseT/100BaseTX, 1x RS-485 (incl. Polarization resistors 47 kΩ, no termination), 1x RS-232, 1x USB2.0, 1x Reset push button

Terminal:

KNX bus: Bus connecting terminal 2 x 0.8 mm

Power supply: Clamp, 0.5 mm²-1.5 mm²

Serial: Clamp, 0.5 mm²-1.5 mm²

Operation: -5°C to +45°C

Environment: Can be used at elevations up to 2000 m above sea level (MSL)

Max. humidity: 93 %, no condensation

Dimension: 90 x 52 x 58 mm (HxWxD)

Device width: 3 modules = approx. 54 mm

Getting to know U.motion

U.motion, a networked system

U.motion is a web-server-based visualisation system for house and building automation networks that have been constructed with a KNX basis. The core of the system is a server that manages the various functions of the U.motion system and the KNX installation. The functions are visualised and controlled using different "client devices":

- U.motion Client Touch panels in different sizes
 - Smartphones and tablet PCs with the corresponding apps for U.motion
 - Standard computers (PC/Mac) with suitable browsers
- The devices can be connected to the server either through a local network or over the Internet.

U.motion links and manages the following functions:

- Controlling lighting, shading and temperature
- Energy management and load control
- Communication within the building (intercom and communication with the door station)
- Building monitoring with IP cameras
- Messages via e-mail, RSS feed, weather forecast, time synchronisation and remote control via Internet connection

The system can be expanded in many ways. From a small system with building control using smartphones and tablet PCs, through to a large system with multiple touch panels, video door stations and IP cameras, there are appropriate solutions for both residential and commercial buildings.

Design options

There is a uniform standard user interface for U.motion devices and it comes in two different design variants. Functions can be grouped together in different ways:

- As rooms and floors
- As functions
- As scenes
- As favourites

All the display variants are available in the default setting. If necessary, you can arrange the different variants individually. The "Functions in the visualisation" section contains an overview of the most important visualisation functions.

If multiple users use the visualisation system, it can be configured individually for each of them. The rooms can be set up specifically for each user group.

End users also have the option of making individual design changes:

- Adjusting and deactivating time functions
- Changing set values for automatic functions
- Changing device values within scenes
- Individual settings via load control: changing the limits, disabling/enabling load shedding
- Positioning elements in the room visualisation
- Grouping together the most important functions as favourites

Server and touch panel: a brief introduction

Server

Depending on the system requirements and size, there is a choice of different servers:



U.motion KNX Server

A DIN rail device that supports a small to medium-sized KNX installation



U.motion KNX Server Plus

A DIN rail device that supports the functions in a larger system, including door communication

Touch panels with integrated server

Touch panels with the functions of a server. The benefit: all the functions are visualised and accessed directly



U.motion KNX Server Plus Touch 10

The touch panel has a screen diagonal of 10 inches



U.motion KNX Server Plus Touch 15

The touch panel has a screen diagonal of 15 inches

Touch panels

Touch panels call up functions and can also access the server's configuration area. The U.motion Client Touch is available in different sizes:



U.motion Client Touch 7

The smallest touch panel with an Android system. You can call up functions from here and also use apps. U.motion Client Touch 7 can be installed either horizontally or vertically.



U.motion Client Touch 10

The touch panel has a screen diagonal of 10 inches



U.motion Client Touch 15

The touch panel has a screen diagonal of 15 inches

System design

There are essentially three extensions for the U.motion visualisation system:

- Solution with **U.motion KNX Server Plus**
- Solution with **U.motion KNX Server**
- Solution with **U.motion KNX Server Plus, Touch**

U.motion is a web-server-based visualisation system for house and building automation networks that have been constructed with a KNX basis. The core of the system is a server that manages the various functions of the U.motion system and the KNX installation. The functions are visualised and controlled using different "client devices":

- U.motion Client Touch panels in different sizes
- Smartphones and tablet PCs with the corresponding apps for U.motion
- Standard computers (PC/Mac) with suitable browsers

The server is configured directly on its web interface in a browser. It can also be configured offline using the U.motion Builder, which is available free of charge.

The following sections describe the system limits and applications of each server, as well as an overview of the visualisation functions. The section on the U.motion door communication describes how the intercom is connected to door stations.

Solution with U.motion KNX Server Plus

The following client devices can use the Server Plus as a master:

- U.motion Client Touch 7
- U.motion Client Touch 10
- U.motion Client Touch 15
- Smartphones
- Tablet PCs
- Devices with a suitable browser (PCs and Macs)

The following technologies are grouped together in the visualisation system:

- KNX building automation
- Monitoring with IP cameras
- Intercom between internal devices
- Door communication between internal devices and door stations
- Internet services, e.g. RSS news, weather forecast and system e-mails
- Family board for messages to the display devices

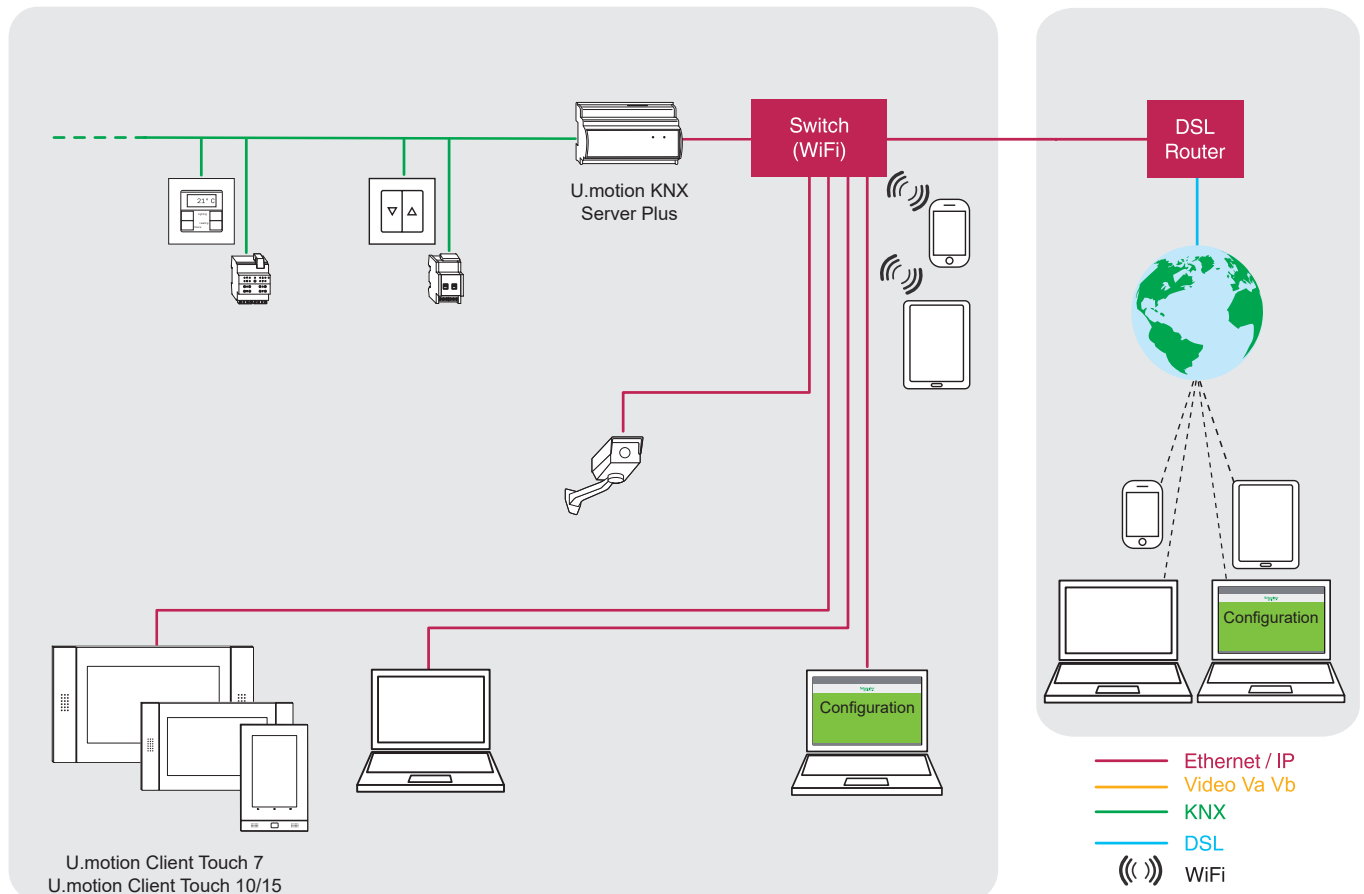

U.motion

Solution with U.motion KNX Server

The following client devices can use the Server as a master:

- U.motion Client Touch 7
- Smartphones
- Tablet PCs
- PCs* or Macs*

The following technologies are grouped together in the visualisation system:

- KNX building automation
- Monitoring with IP cameras
- Internet services, e.g. RSS news, weather forecast and system e-mails
- Family board for messages to the display devices

* two hour time limit after logging on for PCs and Macs

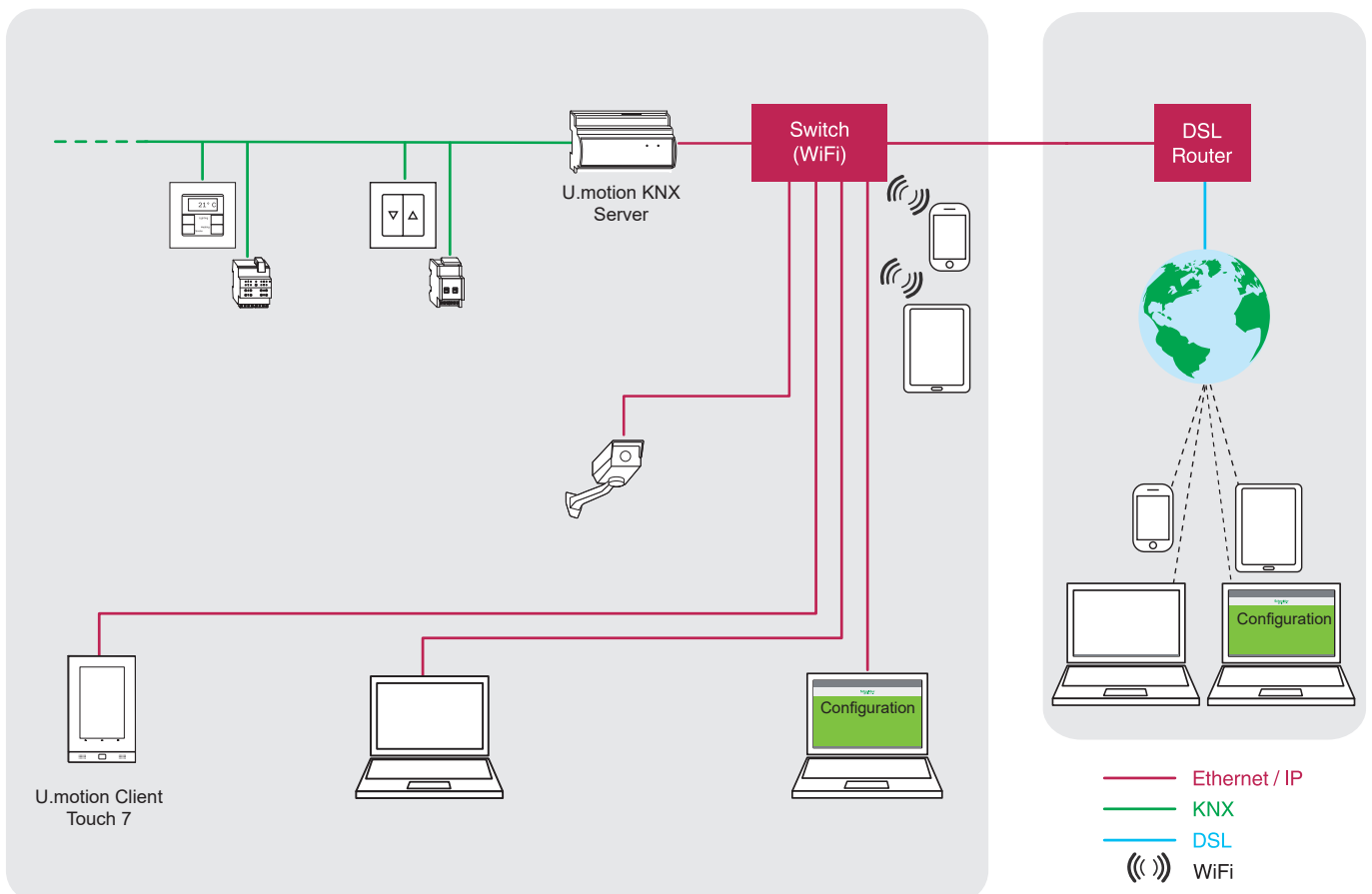

Solution with U.motion KNX Server Plus, Touch

The following client devices can use the Server Plus as a master:

- U.motion Client Touch 7
- Smartphones
- Tablet PCs
- PCs* and Macs*

The following technologies are grouped together in the visualisation system:

- KNX building automation
- Monitoring with IP cameras
- Intercom between internal devices
- Door communication between internal devices and door stations
- Internet services, e.g. RSS news, weather forecast and system e-mails
- Family board for messages to the display devices

* two hour time limit after logging on for PCs and Macs

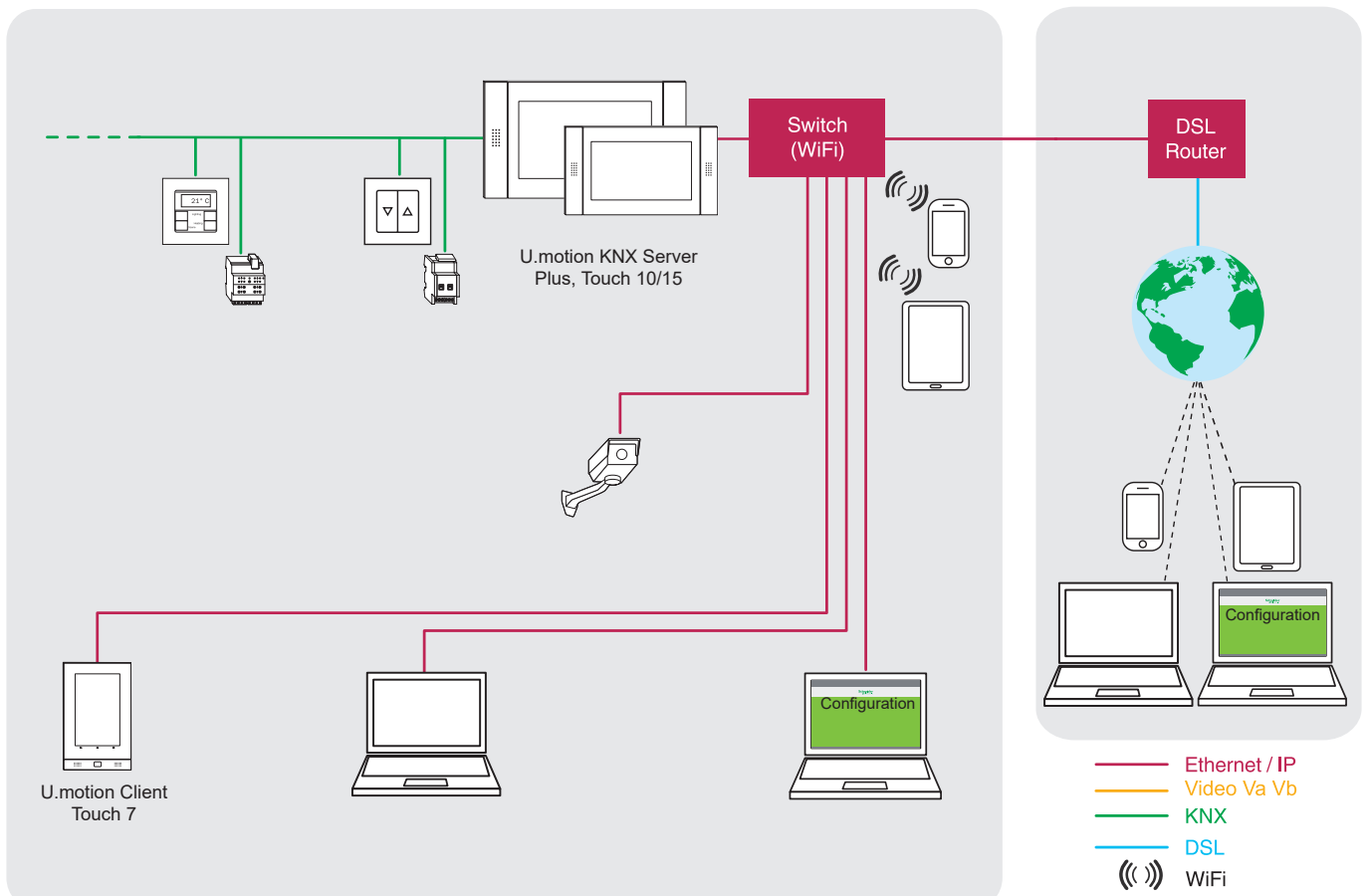

U.motion server



U.motion KNX Server



Version

Art. no.

MTN6501-0001**Discontinued**

The U.motion KNX Server visualises, manages and controls KNX building functions across platforms e.g. building monitoring with IP cameras or visualising the energy efficiency. The KNX server is suitable for controlling buildings with up to 150 KNX group addresses. (e.g. single-family house, shop)

The server acts as a master and provides "client devices" with all the data and functions for visualisation. The client devices include:

- U.motion Client Touch 7
- Smartphones and tablet PCs with the U.motion Control app (Android and iOS)

It is possible to access the server either via the local network or through the Internet via remote access. Automatic size adjustment ensures that the image fits various mobile devices perfectly.

Configuration is carried out using U.motion Builder software and parameterisation either occurs directly on its web interface or offline in a different location.

For installation on DIN rails TH35 according to EN 60715.

Functions: Controllable elements: Display/compare lighting, heating/cooling, shading, temperature control and energy consumption values as well as switch loads on/off, weather stations, IP cameras

Advanced functions: Scenarios, complex objects for combining functions, logic functions, comparisons of values and conditions, virtual objects, integrators, time switch, notifications on the screen and via e-mail.

Visualisation: Different representations of the floor plans and controllable elements, personalisation of the navigation menu, creation of favourites.

System properties: KNX group addresses: 150

Scenes: 5

Logic units: 5

Conditions: 5

Areas/rooms: 10

Energy management: 1 energy meters, 4 loads

IP cameras: 2

Intercom function: No

Nominal voltage: DC 12 - 24 V

Energy consumption: 3 W (240 mA at 12 V)

Connections and interfaces:

1x LAN connection, Ethernet RJ45, 10/100 Mbit/s

IP protection rating: IP 20

Device width: 9 modules = approx. 162 mm

To be completed with: Power supply REG, 24 V DC / 0.4 A MTN693003

Accessories: U.motion Client Touch 7 MTN6260-0307

Contents: Plug-in screw terminals.

U.motion USB stick with additional software and documentation.



U.motion KNX Server Plus



Version

Art. no.

MTN6501-0002**Discontinued**

The U.motion KNX Server Plus visualises, manages and controls KNX building functions across platforms e.g. communication with door stations (IP-SIP), building monitoring with IP cameras or visualising the energy efficiency.

The KNX Server Plus is suitable for controlling larger residential buildings, office buildings, schools, etc. It supports communication with a door station and VoIP intercom.

The Server Plus acts as a master and provides "client devices" with all the data and functions for visualisation. The client devices include:

- U.motion Client Touch 7
- U.motion Client Touch 10/15
- Smartphones and tablet PCs with the U.motion Control app (Android and iOS) and U.motion Communication app (Android)
- Standard computers (PC/Mac) with suitable browsers

It is possible to access the server either via the local network or through the Internet via remote access. Automatic size adjustment ensures that the image fits various mobile devices perfectly.

Configuration is carried out using U.motion Builder software and parameterisation either occurs directly on its web interface or offline in a different location.

For installation on DIN rails TH35 according to EN 60715.

Functions: Controllable elements: Display/compare lighting, heating/cooling, shading, temperature control and energy consumption values as well as switch loads on/off, weather stations, IP cameras, door communication, VoIP intercom.

Advanced functions: Scenarios, complex objects for combining functions, logic functions, comparisons of values and conditions, virtual objects, integrators, time switch, notifications on the screen and via e-mail.

Visualisation: Different representations of the floor plans and controllable elements, personalisation of the navigation menu, creation of favourites.

System properties: KNX group addresses: 1000

Scenes: 50

Logic units: 100

Conditions: 100

Areas/rooms: unlimited number

Energy management: 10 energy meters, 30 loads

IP cameras: unlimited number

Intercom function: Yes

Nominal voltage: DC 12 - 24 V

Energy consumption: 3 W (240 mA at 12 V)

Connections and interfaces:

1x LAN connection, Ethernet RJ45, 10/100 Mbit/s

IP protection rating: IP 20

Device width: 9 modules = approx. 162 mm

To be completed with: Power supply REG, 24 V DC / 0.4 A MTN693003

Accessories: U.motion Client Touch 7 MTN6260-0307

U.motion Client Touch 10 MTN6260-0310

U.motion Client Touch 15 MTN6260-0315

U.motion Door station set, 1 unit MTN6910-0033

U.motion Door station set, 2 units MEG6910-0034

Contents: Plug-in screw terminals.

U.motion USB stick with additional software and documentation.



U.motion KNX Server Plus, Touch 10



Version

Art. no.

MTN6260-0410**Discontinued**

The U.motion KNX Server Plus Touch visualises, manages and controls KNX building functions across platforms e.g. communication with door stations (IP-SIP), building monitoring with IP cameras or visualising the energy efficiency.

Both the visualisation and configuration can be called up using the touch-sensitive screen. The KNX Server Plus Touch is suitable for controlling larger residential buildings, office buildings, schools, etc. It supports communication with a door station and VoIP intercom.

The Server Plus Touch acts as a master and provides "client devices" with all the data and functions for visualisation. The client devices include:

- U.motion Client Touch 7
- Smartphones and tablet PCs with the U.motion Control app (Android and iOS) and U.motion Communication app (Android)

It is possible to access the server either via the local network or through the Internet via remote access. Automatic size adjustment ensures that the image fits various mobile devices perfectly.

Configuration is carried out using U.motion Builder software and parameterisation either occurs directly on its web interface or offline in a different location.

Suitable for flush-mounted installation, cavity wall installation and cavity wall installation in which the touch panel is flush-mounted with the wall.

For horizontal installation.

Functions: Controllable elements: Display/compare lighting, heating/cooling, shading, temperature control and energy consumption values as well as switch loads on/off, weather stations, IP cameras, door communication, VoIP intercom.

Advanced functions: Scenarios, complex objects for combining functions, logic functions, comparisons of values and conditions, virtual objects, integrators, time switch, notifications on the screen and via e-mail.

Visualisation: Different representations of the floor plans and controllable elements, personalisation of the navigation menu, creation of favourites.

System properties: KNX group addresses: 1000

Scenes: 50

Logic units: 100

Conditions: 100

Areas/rooms: unlimited number

Energy management: 10 energy meters, 30 loads

IP cameras: unlimited number

Intercom function: Yes

Nominal voltage: AC 100 - 240 V

Energy consumption: max. 20 W

Connections and interfaces:

1 x LAN connection, Ethernet RJ45, 10/100/1000 Mbit/s

4x USB (1x front, 3x back), KNX interface

Display size: 25.6 cm (10.1")

Display type: TFT, capacitive touchscreen

Resolution: WSVGA 1024x600

Light intensity: 200 cd/m²

Contrast ratio: 400:1

Features: Loudspeaker, microphone

IP protection rating: IP 20

Dimensions: 343x201x81 mm (LxHxW)

To be completed with: U.motion Touch 10 Flush mounting box MTN6270-5004

U.motion Touch 10 Cavity wall set MTN6270-5005

U.motion Touch 10 Cavity wall set, flush mounting MTN6270-5006

Accessories: U.motion Client Touch 7 MTN6260-0307

U.motion Door station set, 1 unit MTN6910-0033

U.motion Door station set, 2 units MEG6910-0034

Contents: U.motion Touch 10 design elements.

RJ45 connection adapter and Cat 6 patch cable 35 cm.

U.motion USB stick with additional software and documentation.



U.motion KNX Server Plus, Touch 15



Version

Art. no.

MTN6260-0415**Discontinued**

The U.motion KNX Server Plus Touch visualises, manages and controls KNX building functions across platforms e.g. communication with door stations (IP-SIP), building monitoring with IP cameras or visualising the energy efficiency.

Both the visualisation and configuration can be called up using the touch-sensitive screen. The KNX Server Plus Touch is suitable for controlling larger residential buildings, office buildings, schools, etc. It supports communication with a door station and VoIP intercom.

The Server Plus Touch acts as a master and provides "client devices" with all the data and functions for visualisation. The client devices include:

- U.motion Client Touch 7
- Smartphones and tablet PCs with the U.motion Control app (Android and iOS) and U.motion Communication app (Android)

It is possible to access the server either via the local network or through the Internet via remote access. Automatic size adjustment ensures that the image fits various mobile devices perfectly.

Configuration is carried out using U.motion Builder software and parameterisation either occurs directly on its web interface or offline in a different location.

Suitable for flush-mounted installation, cavity wall installation and cavity wall installation in which the touch panel is flush-mounted with the wall.

For horizontal installation.

Functions: Controllable elements: Display/compare lighting, heating/cooling, shading, temperature control and energy consumption values as well as switch loads on/off, weather stations, IP cameras, door communication, VoIP intercom.

Advanced functions: Scenarios, complex objects for combining functions, logic functions, comparisons of values and conditions, virtual objects, integrators, time switch, notifications on the screen and via e-mail.

Visualisation: Different representations of the floor plans and controllable elements, personalisation of the navigation menu, creation of favourites.

System properties: KNX group addresses: 1000

Scenes: 50

Logic units: 100

Conditions: 100

Areas/rooms: unlimited number

Energy management: 10 energy meters, 30 loads

IP cameras: unlimited number

Intercom function: Yes

Nominal voltage: AC 100 - 240 V

Energy consumption: max. 25 W

Connections and interfaces:

1 x LAN connection, Ethernet RJ45, 10/100/1000 Mbit/s

4x USB (2x front, 2x back), KNX interface

Display size: 39.6 cm (15.6")

Display type: TFT, capacitive touchscreen

Resolution: WXGA 1366x786

Light intensity: 300 cd/m²

Contrast ratio: 500:1

Features: Loudspeaker, microphone

IP protection rating: IP 20

Dimensions: 525x306x92 mm (LxHxW)

To be completed with: U.motion Touch 15 Flush mounting box MTN6270-5007

U.motion Touch 15 Cavity wall set MTN6270-5008

U.motion Touch 15 Cavity wall set, flush mounting MTN6270-5009

Accessories: U.motion Client Touch 7 MTN6260-0307

U.motion Door station set, 1 unit MTN6910-0033

U.motion Door station set, 2 units MEG6910-0034

Contents: U.motion Touch 15 design elements

RJ45 connection adapter and Cat 6 patch cable 35 cm.

U.motion USB stick with additional software and documentation.

U.motion client



U.motion Client Touch 7, Version 2



Version	Art. no.
Version 2	MTN6260-0307

Using the U.motion Client Touch, it is possible to visualise and control the functions transferred from a U.motion KNX server.

These functions include:

- Control of the lighting, blinds and room temperature control, scenarios
- Visualisation of the energy efficiency
- In conjunction with a KNX Server Plus, communication within a building is possible (intercom, communication with the door station)
- Building monitoring using IP cameras

Operation is interactive on the touch-sensitive TFT display.

The touch panel uses the Android operating system, which means the image is displayed on the device by an Android app. You can use the pre-installed U.motion Access app to configure the most frequently used apps on the front panel, e.g. the U.motion Control app (to control the KNX installation) and the U.motion Communication app (for the intercom system).

Can be flush-mounted and installed in cavity walls.

For horizontal and vertical installation.

Nominal voltage: DC 12 - 32 V or alternatively via PoE (compatible with Cat5e/Cat6 UTP cable, maximum length 100 m, IEEE standard 802.3at)

Energy consumption: max. 7 W

Connections and interfaces:

1x LAN connection, Ethernet RJ45, 10/100 Mbit/s

2x USB 2.0

Display size: 17.78 cm (7")

Display type: TFT, capacitive touchscreen

Resolution: WSVGA (1024*600)

Light intensity: 500 cd/m²

Contrast ratio: 400:1

Features: Loudspeaker, microphone

IP protection rating: IP 20

Dimensions: 136x215x31 mm (LxHxW)

To be completed with: U.motion Touch 7 Mounting Set MTN6270-5001

U.motion KNX Server MTN6501-0001

U.motion KNX Server Plus MTN6501-0002

U.motion KNX Server Plus, Touch 10 MTN6260-0410

U.motion KNX Server Plus, Touch 15 MTN6260-0415

Inside Control, MTN6500-0113

Wiser for KNX, LSS100100

spaceLYnk, LSS100200

Contents: U.motion Touch 7 design elements.

RJ45 connection adapter and Cat 6 patch cable 35 cm.

U.motion USB stick with additional software and documentation.



U.motion Client Touch 10



Version

Art. no.

MTN6260-0310

Using the U.motion Client Touch, it is possible to visualise and control the functions transferred from a U.motion KNX server.

These functions include:

- Control of the lighting, blinds and room temperature control, scenarios
- Visualisation of the energy efficiency
- In conjunction with a KNX Server Plus, communication within a building is possible (inter-com, communication with the door station)
- Building monitoring using IP cameras

Operation is interactive on the touch-sensitive TFT display.

The touch panel has its own administration system where functions, such as language, network parameters, date, screensaver, energy saving mode, etc., can be configured. You can either gain access to the administration system locally on the device or via its web interface, which can be called up on a browser.

After configuration the image is displayed directly on the touch panel.

Suitable for flush-mounted installation, cavity wall installation and cavity wall installation in which the touch panel is flush-mounted with the wall.

For horizontal installation.

Nominal voltage: AC 100 - 240 V

Energy consumption: max. 20 W

Connections and interfaces:

1 x LAN connection, Ethernet RJ45, 10/100/1000 Mbit/s

4x USB (1x front, 3x back)

Display size: 25.6 cm (10.1")

Display type: TFT, capacitive touchscreen

Resolution: WSVGA 1024x600

Light intensity: 200 cd/m²

Contrast ratio: 400:1

Features: Loudspeaker, microphone

IP protection rating: IP 20

Dimensions: 343x201x81 mm (LxHxW)

To be completed with: U.motion Touch 10 Flush mounting box MTN6270-5004

U.motion Touch 10 Cavity wall set MTN6270-5005

U.motion Touch 10 Cavity wall set, flush mounting MTN6270-5006

U.motion KNX Server Plus MTN6501-0002

Contents: U.motion Touch 10 design elements.

RJ45 connection adapter and Cat 6 patch cable 35 cm.

U.motion USB stick with additional software and documentation.



U.motion Client Touch 15



Version

Art. no.

MTN6260-0315

Using the U.motion Client Touch, it is possible to visualise and control the functions transferred from a U.motion KNX server.

These functions include:

- Control of the lighting, blinds and room temperature control, scenarios
- Visualisation of the energy efficiency
- In conjunction with a KNX Server Plus, communication within a building is possible (inter-com, communication with the door station)
- Building monitoring using IP cameras

Operation is interactive on the touch-sensitive TFT display.

The touch panel has its own administration system where functions, such as language, network parameters, date, screensaver, energy saving mode, etc., can be configured. You can either gain access to the administration system locally on the device or via its web interface, which can be called up on a browser.

After configuration the image is displayed directly on the touch panel.

Suitable for flush-mounted installation, cavity wall installation and cavity wall installation in which the touch panel is flush-mounted with the wall.

For horizontal installation.

Nominal voltage: AC 100 - 240 V

Energy consumption: max. 25 W

Connections and interfaces:

1 x LAN connection, Ethernet RJ45, 10/100/1000 Mbit/s

4x USB (2x front, 2x back)

Display size: 39.6 cm (15.6")

Display type: TFT, capacitive touchscreen

Resolution: WXGA 1366x786

Light intensity: 300 cd/m²

Contrast ratio: 500:1

Features: Loudspeaker, microphone

IP protection rating: IP 20

Dimensions: 525x306x92 mm (LxHxW)

To be completed with: U.motion Touch 15 Flush mounting box MTN6270-5007

U.motion Touch 15 Cavity wall set MTN6270-5008

U.motion Touch 15 Cavity wall set, flush mounting MTN6270-5009

U.motion KNX Server Plus MTN6501-0002

Contents: U.motion Touch 15 design elements

RJ45 connection adapter and Cat 6 patch cable 35 cm.

U.motion USB stick with additional software and documentation.

U.motion accessories



U.motion Touch 7 Mounting Set



Version Art. no.

MTN6270-5001

For flush-mounted installation and cavity wall installation of the U.motion Client Touch 7.

Dimensions: 211x130x80 mm (LxHxD)

To be completed with: U.motion Client Touch 7 MTN6260-0307

Contents: Installation box and wood elements for attachment in cavity walls.



U.motion Touch 10 Flush mounting box



Version Art. no.

MTN6270-5004

For flush-mounted installation of U.motion Touch 10 devices.

Dimensions: 325x202x80 mm (LxHxD)

To be completed with: U.motion KNX Server Plus, Touch 10 MTN6260-0410

U.motion Client Touch 10 MTN6260-0310



U.motion Touch 15 Flush mounting box

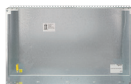

Version Art. no.

MTN6270-5007

For flush-mounted installation of U.motion Touch 15 devices.

Dimensions: 508x308x80 mm (LxHxD)

To be completed with: U.motion KNX Server Plus, Touch 15 MTN6260-0415

U.motion Client Touch 15 MTN6260-0315



U.motion Touch 10 Cavity wall set



Version Art. no.

MTN6270-5005

For cavity wall installation of U.motion Touch 10 devices.

Dimensions: 354x211x47 mm (LxHxD)

To be completed with: U.motion KNX Server Plus, Touch 10 MTN6260-0410

U.motion Client Touch 10 MTN6260-0310

U.motion



U.motion Touch 15 Cavity wall set



Version	Art. no.
---------	----------

MTN6270-5008

For cavity wall installation of U.motion Touch 15 devices.
Dimensions: 537x318x59 mm (LxHxD)
To be completed with: U.motion KNX Server Plus, Touch 15 MTN6260-0415
 U.motion Client Touch 15 MTN6260-0315



U.motion Touch 10 Cavity wall set, flush mounting



Version	Art. no.
---------	----------

MTN6270-5006

For cavity wall installation of U.motion Touch 10 devices. The touch panel is flush-mounted with the wall using this set.
Dimensions: 341x196x88 mm (LxHxD)
To be completed with: U.motion KNX Server Plus, Touch 10 MTN6260-0410
 U.motion Client Touch 10 MTN6260-0310



U.motion Touch 15 Cavity wall set, flush mounting



Version	Art. no.
---------	----------

MTN6270-5009

For cavity wall installation of U.motion Touch 15 devices. The touch panel is flush-mounted with the wall using this set.
Dimensions: 522x302x90 mm (LxHxD)
To be completed with: U.motion KNX Server Plus, Touch 15 MTN6260-0415
 U.motion Client Touch 15 MTN6260-0315



U.motion Touch 7 Design element



Version	Art. no.
---------	----------

MTN6270-4060

Aluminium cover for the U.motion Client Touch 7.
 The cover is pushed on.
Spare part of: U.motion Client Touch 7 MTN6260-0307
Contents: 1 design element made of aluminium.

**U.motion Touch 10 Design element**

Version

Art. no.

MTN6270-4160

Two aluminium covers for U.motion Touch 10 devices.

The covers are pushed on from the side.

Spare part of: U.motion KNX Server Plus, Touch 10 MTN6260-0410

U.motion Client Touch 10 MTN6260-0310

Contents: 2 design elements made of aluminium.

**U.motion Touch 15 Design element**

Version

Art. no.

MTN6270-4260

Two aluminium covers for U.motion Touch 15 devices.

The covers are pushed on from the side.

Spare part of: U.motion KNX Server Plus, Touch 15 MTN6260-0415

U.motion Client Touch 15 MTN6260-0315

Contents: 2 design elements made of aluminium.

Visualization



KNX InSideControl IP-Gateway



Version	Art. no.
light grey	MTN6500-0113 Discontinued

The KNX InSideControl IP-Gateway connects the KNX installation with the IP network (LAN). In combination with the applications "InSideControl App/HD App", the KNX installation can be controlled with up to 5 smartphones or tablets.

The gateway supports the internet protocol DHCP simultaneously. The IP address can be assigned dynamically via a DHCP server or manually via ETS settings. When accessing over KNXnet/IP tunnelling, a maximum of 5 simultaneous connections is possible.

The gateway can additionally serve as a programming interface in order to connect a PC with the KNX bus (e.g. for ETS programming with suitable ETS).

With integrated bus coupler. For installation on DIN rails TH35 according to EN 60715.

The bus is connected using a bus connecting terminal.

KNX software functions: Device name, IP address assignment (DHCP / Manual)

InSideControl App/HD App for smartphones and tablets:

The application is available for the operating systems Apple and Android. It operates only with the KNX InSideControl IP-Gateway. The features of the application are being configured with the additional software InSideControl Builder. The application, as well as the configuration software, are available for free at www.schneider-electric.com.

Functions: The app can be used, for example, to individually control the lighting, blinds or heating or to call up scenes for simultaneously controlling several devices. In addition, messages can be received from the KNX installation, such as a wind message or the indication of the energy consumption.

External power supply: 12-24 V AC or 12-30 V DC (SELV) or Power over Ethernet

Power consumption: max. 800 mW

Operating elements: Programming button

Display elements: 1 LED each for programming, KNX and Ethernet

Connection cross section: Supply: 2x1,5 mm²

Device width: 2 modules = approx. 36 mm

In KNX, to be completed with: Power supply REG, 24 V DC / 0.4 A MTN693003, Power supply REG, AC 24 V/1 A MTN663529, Also alternatively Power over Ethernet (PoE).

Accessories: InSideControl App, InSideControl HD App, Inside Control TP App, InSideControl Builder, U.motion Client Touch 7, Version 2, MTN6260-0307.

<http://www2.schneider-electric.com/sites/corporate/en/products-services/product-launch/KNX/KNX-inside-control.page>

Note: Apple and Android are registered trademarks and property of the respective owners.

Contents: With bus connecting terminal.

Control and display devices

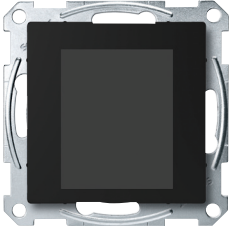

KNX Multitouch Pro



Version

Art. no.

MTN6215-0310

New

For System M.

Comfortable room controller for controlling up to 32 room functions and the room temperature. All functions are displayed on a touch screen and are called up using simple finger movements. The user chooses from 3 interface designs that can be freely assigned to the room functions. The room temperature control can be shown in 2 different designs.

With room temperature control unit, display and connection for the remote sensor.

The room temperature control unit can be used for heating and cooling with infinitely adjustable KNX valve drives or to trigger switch actuators and heating actuators.

ETS device functions:

- Switch-on behaviour of the user interface
- Proximity function: The display and the start screen only become visible when approached
- Gesture function: The device recognises a gesture (horizontal or vertical swipe movement) and triggers a function. In this way, the light can be switched on when you enter the room, for example.
- Cleaning mode: For a specific period of time, neither touches nor gestures are detected
- Adjusting the background lighting
- Setting the screen saver

With integrated bus coupler. The bus is connected using a bus connecting terminal.

KNX software functions:**Control unit/push-button:**

Switching, toggling, dimming (single/dual-surface), blind (single/dual-surface), pulse edges trigger 1-, 2-, 4- or 8-bit telegrams, pulse edges with 2-byte telegrams, 8-bit linear regulator, scene retrieval, scene saving, signal function, fan control, operating modes, setpoint adjustment

Functions of the room temperature control unit:

Controller type: 2-step controller, continuous-action PI control, switching PI control (PWM)

Output: continuous in the range 0 to 100% or switching ON/OFF

Controller mode:

- Heating with one controller output
- Cooling with one controller output
- Heating and cooling with separate controller outputs
- 2-step heating with 2 control outputs
- 2-step cooling with 2 control outputs
- 2-step heating and cooling with 4 control outputs

Operating modes: Comfort, comfort extension, standby (ECO), night reduction, frost/heat protection

Move all setpoints. Save all setpoint temperatures and operating modes when reset. External temperature monitoring. Additional output of the control value as 1 byte value on the PWM.

Signal function for the actual temperature, valve protection function.

Scene function.

Operation: Touch display

Accessories: Dismantling protection MTN6270-0000

Remote sensor for universal room temperature control unit with touch display MTN5775-0003

Note: Programmable with ETS4 and higher.

Contents: With bus connecting terminal and supporting plate.

Control and display devices



KNX Multitouch Pro



Version	Art. no.
	MTN6215-5910 New

For System Design.
 Comfortable room controller for controlling up to 32 room functions and the room temperature. All functions are displayed on a touch screen and are called up using simple finger movements. The user chooses from 3 interface designs that can be freely assigned to the room functions. The room temperature control can be shown in 2 different designs. With room temperature control unit, display and connection for the remote sensor. The room temperature control unit can be used for heating and cooling with infinitely adjustable KNX valve drives or to trigger switch actuators and heating actuators.

ETS device functions:

- Switch-on behaviour of the user interface
- Proximity function: The display and the start screen only become visible when approached
- Gesture function: The device recognises a gesture (horizontal or vertical swipe movement) and triggers a function. In this way, the light can be switched on when you enter the room, for example.
- Cleaning mode: For a specific period of time, neither touches nor gestures are detected
- Adjusting the background lighting
- Setting the screen saver

With integrated bus coupler. The bus is connected using a bus connecting terminal.

KNX software functions:

Control unit/push-button:

Switching, toggling, dimming (single/dual-surface), blind (single/dual-surface), pulse edges trigger 1-, 2-, 4- or 8-bit telegrams, pulse edges with 2-byte telegrams, 8-bit linear regulator, scene retrieval, scene saving, signal function, fan control, operating modes, setpoint adjustment

Functions of the room temperature control unit:

Controller type: 2-step controller, continuous-action PI control, switching PI control (PWM)

Output: continuous in the range 0 to 100% or switching ON/OFF

Controller mode:

- Heating with one controller output
- Cooling with one controller output
- Heating and cooling with separate controller outputs
- 2-step heating with 2 control outputs
- 2-step cooling with 2 control outputs
- 2-step heating and cooling with 4 control outputs

Operating modes: Comfort, comfort extension, standby (ECO), night reduction, frost/heat protection

Move all setpoints. Save all setpoint temperatures and operating modes when reset. External temperature monitoring. Additional output of the control value as 1 byte value on the PWM.

Signal function for the actual temperature, valve protection function.

Scene function.

Operation: Touch display

Accessories: Dismantling protection MTN6270-0000

Remote sensor for universal room temperature control unit with touch display MTN5775-0003

Fixing frame for 3-module box MTN6270-0015

D-Life frame, 1-gang, for 3-module box MTN6010-65xx

Note: Programmable with ETS4 and higher.

Contents: With bus connecting terminal and supporting plate.

Dismantling protection



Version	Art. no.
	MTN6270-0000 New

Prevents the KNX Push-button Pro and the KNX Multi-Touch Pro from being removed easily.

In KNX, to be completed with: KNX Push-button Pro System M MTN6180-04..

System Design MTN6180-60..

System Design MTN6181-6035

KNX Multitouch Pro System M MTN6215-03..

System Design MTN6215-59..

System Design MTN6216-5910

Contents: 2 stainless steel hooks.



Control and display devices



KNX Multitouch Pro



Version	Art. no.
	MTN6216-5910 New

For the Danish market.

For System Design.
 Comfortable room controller for controlling up to 32 room functions and the room temperature. All functions are displayed on a touch screen and are called up using simple finger movements. The user chooses from 3 interface designs that can be freely assigned to the room functions. The room temperature control can be shown in 2 different designs.
 With room temperature control unit, display and connection for the remote sensor.
 The room temperature control unit can be used for heating and cooling with infinitely adjustable KNX valve drives or to trigger switch actuators and heating actuators.

ETS device functions:

- Switch-on behaviour of the user interface
- Proximity function: The display and the start screen only become visible when approached
- Gesture function: The device recognises a gesture (horizontal or vertical swipe movement) and triggers a function. In this way, the light can be switched on when you enter the room, for example.
- Cleaning mode: For a specific period of time, neither touches nor gestures are detected
- Adjusting the background lighting
- Setting the screen saver

With integrated bus coupler. The bus is connected using a bus connecting terminal.
 With fixing frame for DK-Fuga wall box.

KNX software functions:

Control unit/push-button:

Switching, toggling, dimming (single/dual-surface), blind (single/dual-surface), pulse edges trigger 1-, 2-, 4- or 8-bit telegrams, pulse edges with 2-byte telegrams, 8-bit linear regulator, scene retrieval, scene saving, signal function, fan control, operating modes, setpoint adjustment

Functions of the room temperature control unit:

Controller type: 2-step controller, continuous-action PI control, switching PI control (PWM)

Output: continuous in the range 0 to 100% or switching ON/OFF

Controller mode:

- Heating with one controller output
- Cooling with one controller output
- Heating and cooling with separate controller outputs
- 2-step heating with 2 control outputs
- 2-step cooling with 2 control outputs
- 2-step heating and cooling with 4 control outputs

Operating modes: Comfort, comfort extension, standby (ECO), night reduction, frost/heat protection

Move all setpoints. Save all setpoint temperatures and operating modes when reset. External temperature monitoring. Additional output of the control value as 1 byte value on the PWM.

Signal function for the actual temperature, valve protection function.

Scene function.

Operation: Touch display

Accessories: Dismantling protection MTN6270-0000

Remote sensor for universal room temperature control unit with touch display

MTN5775-0003

Note: Programmable with ETS4 and higher.

Contents: With fixing frame for DK-Fuga wall box.

With bus connecting terminal.

Remote sensor for universal room temperature control unit with touch display



Version	Art. no.
	MTN5775-0003 New

For use with underfloor heating systems.

To be completed with: Universal temperature control unit insert with touch display MTN5775-0000

Programmable universal temperature control unit insert with touch display MTN5776-0000

KNX Multitouch Pro System M MTN6215-03..

System Design MTN6215-59..

System Design MTN6216-5910



Access control



KNX Access Control eSuite+PC



Version	Art. no.
	MTN6903-6300 Discontinued

With this server it is possible to connect up to 3 external clients with 3 KNX Access Control USB card programmers real time. The connection is done through Ethernet interface. USB dongle license is included for unlimited rooms.

Integration with third party ERP Fidelio, Leonardo, Gialb systems is possible.

Accessories: KNX Access Control RFID Card reader glass MTN6903-60..., KNX Access Control RFID Card holder glass MTN6903-61..., KNX Access Control RTC glass MTN6903-62..., KNX Access Control USB card prog. MTN6903-6301



KNX Access Control USB card prog.



Version	Art. no.
	MTN6903-6301 Discontinued

The device is fitted in a table container with 3 modules, and is equipped with a USB for the connection to a PC.

It is back lighted for signalling transponder reading or writing. The reader / writer is powered up through the USB port of the PC, which must be provided with the appropriate software to allow the following read/write data: system code, password and date.

In KNX, to be completed with: KNX Access Control eSuite+PC MTN6903-6300

Accessories: KNX Access Control RFID Card reader glass MTN6903-60..., KNX Access Control RFID Card holder glass MTN6903-61..



KNX Access Control RFID Card reader glass



Version	Art. no.
white	MTN6903-6019 Discontinued
black	MTN6903-6014 Discontinued
aluminium	MTN6903-6060 Discontinued

The device has two free potential binary inputs for door contact, window contacts, bathroom alarm or other needed inputs. On the device there are two low voltage relays for any other freely configurable use.

The front of the transponder is illuminated if no light is available (for dark locations), goes out if the card is invalid, and flashes for 3 seconds if access is not allowed. It is possible to open the door, execute some lighting scene and any other function through KNX bus.

Configuration is done with ETS.

Nominal voltage: 12/24 VAC/DC and KNX bus connection

Maximum current: 150 mA

Contact voltage: 24 Vdc

Contact current: 1mA

In KNX, to be completed with: Power supply REG, 24 V DC / 0.4 A MTN693003, Power supply REG, AC 24 V/1 A MTN663529

Accessories: KNX Access Control RFID Card holder glass MTN6903-61..., KNX Access Control RTC glass MTN6903-62..., KNX Access Control USB card prog. MTN6903-6301, KNX Access Control eSuite+PC MTN6903-6300

Access Control



KNX Access Control RFID Card holder glass



Version	Art. no.	
white	MTN6903-6119	Discontinued
black	MTN6903-6114	Discontinued
aluminium	MTN6903-6160	Discontinued

The device has two free potential binary inputs for door contact, window contacts, bathroom alarm or other needed inputs. On the device there are two low voltage relays for any other freely configurable use as locker open signal.

The front of the transponder is illuminated if no light is available (for dark locations), goes out if the card is invalid, and flashes for 3 seconds if access is not allowed. It is possible to execute some lighting scene, switch off HVAC system when card is removed and any other function through KNX bus.

Configuration is done with ETS. With integrated bus coupler. The bus is connected using a bus connecting terminal.

Nominal voltage: 12/24 VAC/DC and KNX bus connection

Maximum current: 150 mA

Contact voltage: 24 Vdc

Contact current: 1mA

In KNX, to be completed with: Power supply REG, 24 V DC / 0.4 A MTN693003, Power supply REG, AC 24 V/1 A MTN663529

Accessories: KNX Access Control RFID Card reader glass MTN6903-60..., KNX Access Control RTC glass MTN6903-62..., KNX Access Control USB card prog. MTN6903-6301, KNX Access Control eSuite+PC MTN6903-6300



KNX Access Control RTC glass



Version	Art. no.	
white	MTN6903-6219	Discontinued
black	MTN6903-6214	Discontinued
aluminium	MTN6903-6260	Discontinued

With room temperature control unit and display.

The room temperature control unit can be used for heating and cooling with infinitely adjustable.

KNX valve drives or to trigger switch actuators and heating actuators. With the white backlit display for showing e.g. the fan status, automatic/manual mode, temperature and operating mode.

The push-buttons are freely parameterisable as push-button pairs (dual-surface) or as single push-buttons.

The device has one free potential binary input for door contact, window contacts, bathroom alarm or other needed inputs. On the device there are one low voltage relay for any other freely configurable use as locker open signal.

With integrated bus coupler. The bus is connected using a bus connecting terminal.

Accessories: KNX Access Control RFID Card reader glass MTN6903-60..., KNX Access Control RFID Card holder glass MTN6903-61..., KNX Access Control USB card prog. MTN6903-6301, KNX Access Control eSuite+PC MTN6903-6300

Push-button

Push-buttons System M



KNX Push-button Pro



Version	Art. no.	
<input type="checkbox"/> polar white, glossy	MTN6180-0319	New
<input type="checkbox"/> active white, glossy	MTN6180-0325	New
<input checked="" type="checkbox"/> anthracite	MTN6180-0414	New
<input checked="" type="checkbox"/> aluminium	MTN6180-0460	New

For System M.

Push-button with 1 to 4 operating buttons and status displays. In idle state, the surface of the push-button appears as a uniform plane. The inscription of the keys only becomes visible via the backlit symbols following activation. For this, you can use the enclosed prefabricated foils or the individual symbols with various motifs.

The position of the operating buttons varies depending on the selected number of operating buttons.

ETS device functions:

- Behaviour and brightness of the status displays
- Night mode: LEDs light up with reduced brightness
- Proximity function: The LEDs are only activated and the functions only become visible when approached.

With integrated bus coupler. The bus is connected using a bus connecting terminal.

KNX software functions:

2 programming options:

- Express setting: Calls up a pre-set configuration
 - Advanced setting: Individual configuration
- Switching, toggling, dimming (single/dual-surface), blind (single/dual-surface), pulse edges trigger 1-, 2-, 4- or 8-bit telegrams (distinction between short and long operation), pulse edges with 2-byte telegrams (distinction between short and long operation), 8-bit linear regulator, scene retrieval, scene saving, disable functions.

Accessories: Dismantling protection MTN6270-0000

Foil set for KNX Push-button Pro MTN6270-0010

Note: Programmable with ETS4 and higher.

Contents: Device with inserted prefabricated foil.

With bus connecting terminal and supporting plate.

3 prefabricated foils and 24 different individual symbols with 1 carrier foil.

Foil set for KNX Push-button Pro

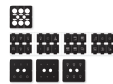

Version	Art. no.	
	MTN6270-0010	New

Spare part

For System M.

For individual marking of the KNX Push-button Pros.

In KNX, to be completed with: KNX Push-button Pro MTN6180-04..

Contents: 3 prefabricated foils and 24 different individual symbols with 1 carrier foil.

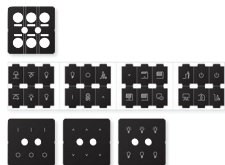

Push-button

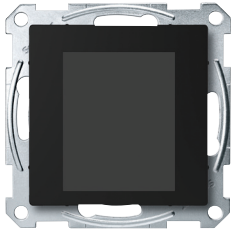

KNX Multitouch Pro



Version	Art. no.
	MTN6215-0310 New

For System M.
 Comfortable room controller for controlling up to 32 room functions and the room temperature. All functions are displayed on a touch screen and are called up using simple finger movements. The user chooses from 3 interface designs that can be freely assigned to the room functions. The room temperature control can be shown in 2 different designs.
 With room temperature control unit, display and connection for the remote sensor.
 The room temperature control unit can be used for heating and cooling with infinitely adjustable KNX valve drives or to trigger switch actuators and heating actuators.

ETS device functions:

- Switch-on behaviour of the user interface
- Proximity function: The display and the start screen only become visible when approached
- Gesture function: The device recognises a gesture (horizontal or vertical swipe movement) and triggers a function. In this way, the light can be switched on when you enter the room, for example.
- Cleaning mode: For a specific period of time, neither touches nor gestures are detected
- Adjusting the background lighting
- Setting the screen saver

With integrated bus coupler. The bus is connected using a bus connecting terminal.

KNX software functions:

Control unit/push-button:

Switching, toggling, dimming (single/dual-surface), blind (single/dual-surface), pulse edges trigger 1-, 2-, 4- or 8-bit telegrams, pulse edges with 2-byte telegrams, 8-bit linear regulator, scene retrieval, scene saving, signal function, fan control, operating modes, setpoint adjustment

Functions of the room temperature control unit:

Controller type: 2-step controller, continuous-action PI control, switching PI control (PWM)

Output: continuous in the range 0 to 100% or switching ON/OFF

Controller mode:

- Heating with one controller output
- Cooling with one controller output
- Heating and cooling with separate controller outputs
- 2-step heating with 2 control outputs
- 2-step cooling with 2 control outputs
- 2-step heating and cooling with 4 control outputs

Operating modes: Comfort, comfort extension, standby (ECO), night reduction, frost/heat protection

Move all setpoints. Save all setpoint temperatures and operating modes when reset. External temperature monitoring. Additional output of the control value as 1 byte value on the PWM.

Signal function for the actual temperature, valve protection function.

Scene function.

Operation: Touch display

Accessories: Dismantling protection MTN6270-0000

Remote sensor for universal room temperature control unit with touch display MTN5775-0003

Note: Programmable with ETS4 and higher.

Contents: With bus connecting terminal and supporting plate.

Remote sensor for universal room temperature control unit with touch display



Version	Art. no.
	MTN5775-0003 New

For use with underfloor heating systems.

To be completed with: Universal temperature control unit insert with touch display MTN5775-0000

Programmable universal temperature control unit insert with touch display MTN5776-0000

KNX Multitouch Pro System M MTN6215-03..

System Design MTN6215-59..

System Design MTN6216-5910



Push-button



Dismantling protection



Version	Art. no.
	MTN6270-0000 New

Prevents the KNX Push-button Pro and the KNX Multi-Touch Pro from being removed easily.
In KNX, to be completed with: KNX Push-button Pro System M MTN6180-04..
 System Design MTN6180-60..
 System Design MTN6181-6035
 KNX Multitouch Pro System M MTN6215-03..
 System Design MTN6215-59..
 System Design MTN6216-5910
Contents: 2 stainless steel hooks.

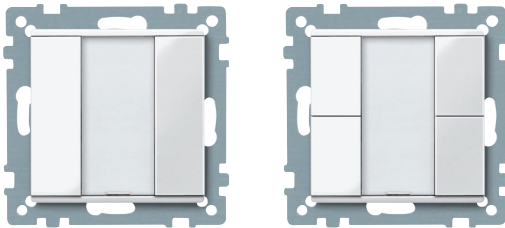

Push-button, 1-gang plus		Push-button, 2-gang plus	
--------------------------	--	--------------------------	--

Push-button, 1-gang plus		Push-button, 2-gang plus	
Version	Art. no.	Version	Art. no.
<input checked="" type="checkbox"/> white, glossy	MTN617144	<input checked="" type="checkbox"/> white, glossy	MTN617244
<input type="checkbox"/> polar white, glossy	MTN617119	<input type="checkbox"/> polar white, glossy	MTN617219
<input type="checkbox"/> active white, glossy	MTN617125	<input type="checkbox"/> active white, glossy	MTN617225
<input checked="" type="checkbox"/> anthracite	MTN627514	<input checked="" type="checkbox"/> anthracite	MTN627614
<input checked="" type="checkbox"/> aluminium	MTN627560	<input checked="" type="checkbox"/> aluminium	MTN627660

For System M.
 With integrated bus coupling unit.
 Push-button with 2 operating buttons, operating and status display and labelling field. The operating display can also be used as an orientation light.
 The device is connected to the bus line with a bus connecting terminal.
KNX software functions: Switching, toggling, dimming (single/dual-surface), blind (single/dual-surface), pulse edges trigger 1-, 2-, 4- or 8-bit telegrams (distinction between short and long operation), pulse edges with 2-byte telegrams (distinction between short and long operation), 8-bit linear regulator, scene retrieval, scene saving, disable functions.
Accessories: Labelling sheets for push-buttons System M MTN6183..
Contents: With protective hood for plaster. With bus connecting terminal.

For System M.
 With integrated bus coupling unit.
 Push-button with 4 operating buttons, operating and status display and labelling field. The operating display can also be used as an orientation light.
 The device is connected to the bus line with a bus connecting terminal.
KNX software functions: Switching, toggling, dimming (single/dual-surface), blind (single/dual-surface), pulse edges trigger 1-, 2-, 4- or 8-bit telegrams (distinction between short and long operation), pulse edges with 2-byte telegrams (distinction between short and long operation), 8-bit linear regulator, scene retrieval, scene saving, disable functions.
Accessories: Labelling sheets for push-buttons System M MTN6183..
Contents: With protective hood for plaster. With bus connecting terminal.

Push-button

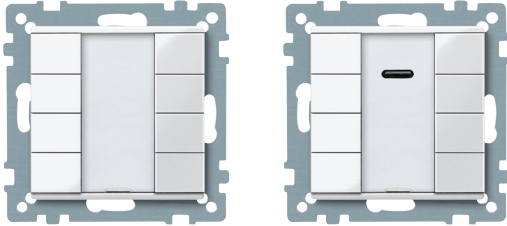

Push-button, 4-gang plus		Push-button, 4-gang plus with IR receiver	
--------------------------	--	---	--

Version	Art. no.	Version	Art. no.
<input checked="" type="checkbox"/> white, glossy	MTN617444	<input checked="" type="checkbox"/> white, glossy	MTN617544
<input type="checkbox"/> polar white, glossy	MTN617419	<input type="checkbox"/> polar white, glossy	MTN617519
<input type="checkbox"/> active white, glossy	MTN617425	<input type="checkbox"/> active white, glossy	MTN617525
<input checked="" type="checkbox"/> anthracite	MTN627814	<input checked="" type="checkbox"/> anthracite	MTN627914
<input checked="" type="checkbox"/> aluminium	MTN627860	<input checked="" type="checkbox"/> aluminium	MTN627960

For System M.
With integrated bus coupling unit.
Push-button with 8 operating buttons, operating and status display and labelling field. The operating display can also be used as an orientation light.
The device is connected to the bus line with a bus connecting terminal.
KNX software functions: Switching, toggling, dimming (single/dual-surface), blind (single/dual-surface), pulse edges trigger 1-, 2-, 4- or 8-bit telegrams (distinction between short and long operation), pulse edges with 2-byte telegrams (distinction between short and long operation), 8-bit linear regulator, scene retrieval, scene saving, disable functions.
Accessories: Labelling sheets for push-buttons System M MTN6183..
Contents: With protective hood for plaster. With bus connecting terminal.

For System M.
With integrated bus coupling unit.
Push-button with 8 operating buttons, operating and status display and labelling field. The operating display can also be used as an orientation light.
The functions of each of the keys can be triggered using an IR remote control.
The push-button is pre-programmed for operation with a Merten IR remote control Distance. Many other IR remote controls (e.g. existing TV or CD player remote controls) can be taught into the push-buttons.
The device is connected to the bus line with a bus connecting terminal.
KNX software functions: Switching, toggling, dimming (single/dual-surface), blind (single/dual-surface), pulse edges trigger 1-, 2-, 4- or 8-bit telegrams (distinction between short and long operation), pulse edges with 2-byte telegrams (distinction between short and long operation), 8-bit linear regulator, scene retrieval, scene saving, disable functions.
Accessories: Labelling sheets for multi-function push-button with IR receiver System M MTN6184..
Transmitter: IR universal remote control MTN5761-0000
Contents: With protective hood for plaster. With bus connecting terminal.

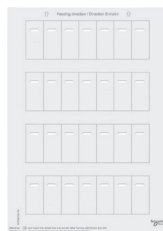
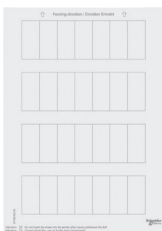

Labelling sheets for push-buttons		Labelling sheets for multi-function push-button with IR receiver	
-----------------------------------	--	--	--

Version	Art. no.	Version	Art. no.
polar white	MTN618319	polar white	MTN618419
silver	MTN618320	silver	MTN618420

For individual labelling of the System M push-buttons with text or symbols.
Accessories from: Push-button, 1-gang plus System M MTN6275.., MTN6171.., Push-button, 2-gang plus System M MTN6276.., MTN6172.., Push-button, 4-gang plus System M MTN6278.., MTN6174..
Contents: 1 sheet for every 28 products.

For individual labelling of the System M multi-function push-button with IR receiver.
Accessories from: Push-button, 4-gang plus with IR receiver System M MTN6279.., MTN6175..
Contents: 1 sheet for every 28 products.

Push-button



Protective hood for plaster



Version

Art. no.

MTN627591

For System M.

To protect push-buttons, rockers, room temperature control units and room controllers from contamination from painting and decorating work.

Accessories from: Push-button, 1-gang plus System M MTN6275..., MTN6171..., Push-button, 2-gang plus System M MTN6276..., MTN6172..., Push-button, 4-gang plus System M MTN6278..., MTN6174..., Push-button, 4-gang plus with IR receiver System M MTN6279..., MTN6175..., Push-button 2-gang plus with room temperature control unit System M MTN6212-03.. /-04..., Rocker for 1-gang push-button module System M MTN6191..., MTN6251..., Rocker for 1-gang push-button module with 1/0 imprint System M MTN6254..., MTN6193..., Rocker for 1-gang push-button module with up/down arrow imprint System M MTN6255..., MTN6194..., Rockers for 2-gang push-button module System M MTN6192..., MTN6252..., Rockers for 2-gang push-button module with 1/0 and up/down arrow imprint System M MTN6256..., MTN6195..., Rockers for 2-gang push-button module with up/down arrow and 1/0 imprint System M MTN6257..., MTN6196..., Rockers for 2-gang push-button module with up/down arrow imprint System M MTN6258..., MTN6197..

Note: When the protective hood for plaster is in place, the temperature measurement of the room temperature control unit is restricted.

Push-button



Push-button 2-gang plus with room temperature control unit



Version	Art. no.
<input checked="" type="checkbox"/> white, glossy	MTN6212-0344
<input type="checkbox"/> polar white, glossy	MTN6212-0319
<input type="checkbox"/> active white, glossy	MTN6212-0325
<input checked="" type="checkbox"/> anthracite	MTN6212-0414
<input type="checkbox"/> aluminium	MTN6212-0460

For System M.

Convenient control unit with 4 operating buttons, operating and status display and labelling field. The operating display can also be used as an orientation light.

With room temperature control unit and display.

With 5 red LEDs.

The room temperature control unit can be used for heating and cooling with infinitely adjustable KNX valve drives or to trigger switch actuators and heating actuators. With the white backlit display for showing e.g. the time, date, temperature and operating mode. Menu for setting default operating modes, setpoint value, working/non-working day (external trigger), display mode, time, switching times and brightness of the display.

The push-buttons are freely parameterisable as push-button pairs (dual-surface) or as single push-buttons.

With integrated bus coupler. The bus is connected using a bus connecting terminal.

KNX software functions:

Functions of the push-buttons:

Switching, toggling, dimming, blind control (relative or absolute), pulse edges trigger 1-, 2-, 4- or 8-bit telegrams (distinction between short and long operation), pulse edges with 2-byte telegrams (distinction between short and long operation), 8-bit linear regulator, scene retrieval, scene saving, disable functions, timed control with synchronisation, notification functions, the cyclic reading of external temperature values, fan control, operating modes, move setpoints.

Functions of the room temperature control unit:

Controller type: 2-step control, continuous PI controller, switching PI controller (PWM)

Output: continuous in the range 0 to 100% or switching ON/OFF

Controller mode:

- Heating with one controller output
- Cooling with one controller output
- Heating and cooling with separate controller outputs
- Heating and cooling with one controller output
- 2-step heating with 2 control outputs
- 2-step cooling with 2 control outputs
- 2-step heating and cooling with 4 control outputs

Operating modes: Comfort, comfort extension, standby, night reduction, frost/heat protection

Move all setpoints, save all setpoint temperatures and operating modes when reset, external temperature monitoring, additional output of the control value as 1 byte value on the PWM.

Monitoring function for the actual temperature, valve protection function.

Scene function.

Operation: Menu.

Contents: With bus connecting terminal and supporting plate.

Screw for protection against dismantling.

With protective hood for plaster.

Push-button

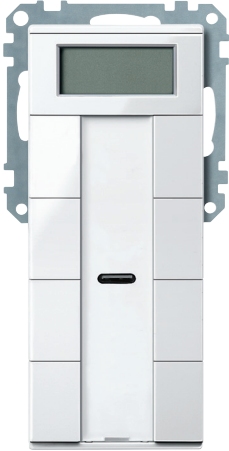

Push-button 4-gang plus with room temperature control unit



Version	Art. no.
<input checked="" type="checkbox"/> white, glossy	MTN6214-0344
<input type="checkbox"/> polar white, glossy	MTN6214-0319
<input type="checkbox"/> active white, glossy	MTN6214-0325
<input checked="" type="checkbox"/> anthracite	MTN6214-0414
<input type="checkbox"/> aluminium	MTN6214-0460

For System M.

Convenient control unit with 8 operating buttons, operating and status display and labelling field. The operating display can also be used as an orientation light.

With room temperature control unit and display.

With integrated piezoelectric buzzer to display alarm states and IR receiver. All functions of the respective buttons can be controlled via IR remote control.

With 9 red LEDs.

The room temperature control unit can be used for heating and cooling with infinitely adjustable KNX valve drives or to trigger switch actuators and heating actuators. With the white backlit display for showing e.g. the time, date, temperature and operating mode. Menu for setting default operating modes, setpoint value, working/non-working day (external trigger), display mode, time, switching times and brightness of the display.

The push-buttons are freely parameterisable as push-button pairs (dual-surface) or as single push-buttons.

With integrated bus coupler. The bus is connected using a bus connecting terminal.

KNX software functions:

Functions of the push-buttons:

Switching, toggling, dimming, blind control (relative or absolute), pulse edges trigger 1-, 2-, 4- or 8-bit telegrams (distinction between short and long operation), pulse edges with 2-byte telegrams (distinction between short and long operation), 8-bit linear regulator, scene retrieval, scene saving, disable functions, timed control with synchronisation, notification functions, the cyclic reading of external temperature values, fan control, operating modes, move setpoints.

Functions of the room temperature control unit:

Controller type: 2-step control, continuous PI controller, switching PI controller (PWM)

Output: continuous in the range 0 to 100% or switching ON/OFF

Controller mode:

- Heating with one controller output
- Cooling with one controller output
- Heating and cooling with separate controller outputs
- Heating and cooling with one controller output
- 2-step heating with 2 control outputs
- 2-step cooling with 2 control outputs
- 2-step heating and cooling with 4 control outputs

Operating modes: Comfort, comfort extension, standby, night reduction, frost/heat protection

Move all setpoints, save all setpoint temperatures and operating modes when reset, external temperature monitoring, additional output of the control value as 1 byte value on the PWM.

Monitoring function for the actual temperature, valve protection function.

Scene function.

Operation: Menu.

Transmitter: IR universal remote control MTN5761-0000

To be completed with: M-Smart frame, 2-gang without central bridge piece MTN4788.., M-Arc frame, 2-gang without central bridge piece MTN4858.., M-Star frame, 2-gang without central bridge piece MTN4668.., MTN4768.., MTN4868.., M-Plan frames, 2-gang without central bridge piece MTN4888.., MTN5158.., Metal frame, 2-gang without central bridge piece M-Elegance MTN4038.., Real glass frame, 2-gang without central bridge piece M-Elegance MTN4048..

Contents: With bus connecting terminal and supporting plate.

Screw for protection against dismantling.

With protective hood for plaster.

Push-button



Rocker for 1-gang push-button module



Version	Art. no.
<input checked="" type="checkbox"/> white, glossy	MTN619144
<input type="checkbox"/> polar white, glossy	MTN619119
<input type="checkbox"/> active white, glossy	MTN619125
<input checked="" type="checkbox"/> anthracite	MTN625114
<input checked="" type="checkbox"/> aluminium	MTN625160

For System M.
The rocker is attached to the 1-gang push-button module.
In KNX, to be completed with: KNX push-button module, 1-gang System M MTN625199
Accessories: Protective hood for plaster System M MTN627591

Rocker for 1-gang push-button module with 1/0 imprint



Version	Art. no.
<input checked="" type="checkbox"/> white, glossy	MTN619344
<input type="checkbox"/> polar white, glossy	MTN619319
<input type="checkbox"/> active white, glossy	MTN619325
<input checked="" type="checkbox"/> anthracite	MTN625414
<input checked="" type="checkbox"/> aluminium	MTN625460

For System M.
The rocker is attached to the 1-gang push-button module.
In KNX, to be completed with: KNX push-button module, 1-gang System M MTN625199
Accessories: Protective hood for plaster System M MTN627591

Rocker for 1-gang push-button module with up/down arrow imprint



Version	Art. no.
<input checked="" type="checkbox"/> white, glossy	MTN619444
<input type="checkbox"/> polar white, glossy	MTN619419
<input type="checkbox"/> active white, glossy	MTN619425
<input checked="" type="checkbox"/> anthracite	MTN625514
<input checked="" type="checkbox"/> aluminium	MTN625560

For System M.
The rocker is attached to the 1-gang push-button module.
In KNX, to be completed with: KNX push-button module, 1-gang System M MTN625199
Accessories: Protective hood for plaster System M MTN627591

KNX push-button module, 1-gang



Version	Art. no.
	MTN625199

For System M.
Push-button module without rocker. With programmable status display.
The device is connected to the bus line with a bus connecting terminal. With integrated bus coupler.
KNX software functions: The push-buttons can be parameterised either as a pair (dual-surface) or individually (single-surface).
Single-surface: Switch ON or switch OFF, dimming, scenes.
Dual-surface: Switch ON or switch OFF, dimming, scenes, blinds.
In KNX, to be completed with: Rocker for 1-gang push-button module System M MTN6191..., MTN6251..., Rocker for 1-gang push-button module with 1/0 imprint System M MTN6254..., MTN6193..., Rocker for 1-gang push-button module with up/down arrow imprint System M MTN6255..., MTN6194..

Push-button



Rockers for 2-gang push-button module



Version	Art. no.
<input checked="" type="checkbox"/> white, glossy	MTN619244
<input type="checkbox"/> polar white, glossy	MTN619219
<input type="checkbox"/> active white, glossy	MTN619225
<input checked="" type="checkbox"/> anthracite	MTN625214
<input type="checkbox"/> aluminium	MTN625260

For System M.
The rockers are attached to the 2-gang push-button module.
To be completed with: Push-button module, 2-gang System M MTN568499
In KNX, to be completed with: KNX push-button module, 2-gang System M MTN625299
Accessories: Protective hood for plaster System M MTN627591

Rockers for 2-gang push-button module with 1/0 and up/down arrow imprint



Version	Art. no.
<input checked="" type="checkbox"/> white, glossy	MTN619544
<input type="checkbox"/> polar white, glossy	MTN619519
<input type="checkbox"/> active white, glossy	MTN619525
<input checked="" type="checkbox"/> anthracite	MTN625614
<input type="checkbox"/> aluminium	MTN625660

For System M.
The rockers are attached to the 2-gang push-button module.
In KNX, to be completed with: KNX push-button module, 2-gang System M MTN625299
Accessories: Protective hood for plaster System M MTN627591



Rockers for 2-gang push-button module with up/down arrow and 1/0 imprint



Version	Art. no.
<input checked="" type="checkbox"/> white, glossy	MTN619644
<input type="checkbox"/> polar white, glossy	MTN619619
<input type="checkbox"/> active white, glossy	MTN619625
<input checked="" type="checkbox"/> anthracite	MTN625714
<input type="checkbox"/> aluminium	MTN625760

For System M.
The rockers are attached to the 2-gang push-button module.
In KNX, to be completed with: KNX push-button module, 2-gang System M MTN625299
Accessories: Protective hood for plaster System M MTN627591

Rockers for 2-gang push-button module with up/down arrow imprint



Version	Art. no.
<input checked="" type="checkbox"/> white, glossy	MTN619744
<input type="checkbox"/> polar white, glossy	MTN619719
<input type="checkbox"/> active white, glossy	MTN619725
<input checked="" type="checkbox"/> anthracite	MTN625814
<input type="checkbox"/> aluminium	MTN625860

For System M.
The rockers are attached to the 2-gang push-button module.
In KNX, to be completed with: KNX push-button module, 2-gang System M MTN625299
Accessories: Protective hood for plaster System M MTN627591

Push-button

KNX push-button module, 2-gang



Version

Art. no.

MTN625299

For System M.

Push-button module without rockers. With programmable status display.

The device is connected to the bus line with a bus connecting terminal. With integrated bus coupler.

KNX software functions: The push-buttons can be parameterised either as a pair (dual-surface) or individually (single-surface).

Single-surface: Switch ON or switch OFF, dimming, scenes.

Dual-surface: Switch ON or switch OFF, dimming, scenes, blinds.

In KNX, to be completed with: Rockers for 2-gang push-button module System M MTN6192..., MTN6252..., Rockers for 2-gang push-button module with 1/0 and up/down arrow imprint System M MTN6256..., MTN6195..., Rockers for 2-gang push-button module with up/down arrow and 1/0 imprint System M MTN6257..., MTN6196..., Rockers for 2-gang push-button module with up/down arrow imprint System M MTN6258..., MTN6197..

Push-button

Push-buttons System Design



KNX Push-button Pro



Version	Art. no.	
Thermoplastic		
<input type="checkbox"/>	lotus white	MTN6180-6035 New
<input checked="" type="checkbox"/>	anthracite	MTN6180-6034 New
<input type="checkbox"/>	sahara	MTN6180-6033 New
<input type="checkbox"/>	stainless steel	MTN6180-6036 New
<input type="checkbox"/>	nickel metallic	MTN6180-6050 New
<input type="checkbox"/>	champagne metallic	MTN6180-6051 New
<input type="checkbox"/>	mocca metallic	MTN6180-6052 New

For System Design.

Push-button with 1 to 4 operating buttons and status displays. In idle state, the surface of the push-button appears as a uniform plane. The inscription of the keys only becomes visible via the backlit symbols following activation. For this, you can use the enclosed prefabricated foils or the individual symbols with various motifs.

The position of the operating buttons varies depending on the selected number of operating buttons.

ETS device functions:

- Behaviour and brightness of the status displays
- Night mode: LEDs light up with reduced brightness
- Proximity function: The LEDs are only activated and the functions only become visible when approached.

With integrated bus coupler. The bus is connected using a bus connecting terminal.

KNX software functions:

2 programming options:

- Express setting: Calls up a pre-set configuration
- Advanced setting: Individual configuration

Switching, toggling, dimming (single/dual-surface), blind (single/dual-surface), pulse edges trigger 1-, 2-, 4- or 8-bit telegrams (distinction between short and long operation), pulse edges with 2-byte telegrams (distinction between short and long operation), 8-bit linear regulator, scene retrieval, scene saving, disable functions.

Accessories: Dismantling protection MTN6270-0000

Foil set for KNX Push-button Pro MTN6270-0011

Fixing frame for 3-module box MTN6270-0015

D-Life frame, 1-gang, for 3-module box MTN6010-65xx

Note: Programmable with ETS4 and higher.

Contents: Device with inserted prefabricated foil.

With bus connecting terminal and supporting plate.

3 prefabricated foils and 24 different individual symbols with 1 carrier foil.

Push-button



KNX Push-button Pro



Version	Art. no.	
<input type="checkbox"/> lotus white	MTN6181-6035	New

For the Danish market.

For System Design.

Push-button with 1 to 4 operating buttons and status displays. In idle state, the surface of the push-button appears as a uniform plane. The inscription of the keys only becomes visible via the backlit symbols following activation. For this, you can use the enclosed prefabricated foils or the individual symbols with various motifs.

The position of the operating buttons varies depending on the selected number of operating buttons.

ETS device functions:

- Behaviour and brightness of the status displays
- Night mode: LEDs light up with reduced brightness
- Proximity function: The LEDs are only activated and the functions only become visible when approached.

With integrated bus coupler. The bus is connected using a bus connecting terminal.

With fixing frame for DK-Fuga wall box.

KNX software functions:

2 programming options:

- Express setting: Calls up a pre-set configuration
 - Advanced setting: Individual configuration
- Switching, toggling, dimming (single/dual-surface), blind (single/dual-surface), pulse edges trigger 1-, 2-, 4- or 8-bit telegrams (distinction between short and long operation), pulse edges with 2-byte telegrams (distinction between short and long operation), 8-bit linear regulator, scene retrieval, scene saving, disable functions.

Accessories: Dismantling protection MTN6270-0000

Foil set for KNX Push-button Pro MTN6270-0011

Note: Programmable with ETS4 and higher.

Contents: With fixing frame for DK-Fuga wall box.

With bus connecting terminal.

Device with inserted prefabricated foil.

3 prefabricated foils and 24 different individual symbols with 1 carrier foil.

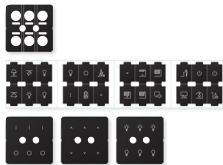

Foil set for KNX Push-button Pro



Version	Art. no.	
	MTN6270-0011	New

Spare part

For System Design.

For individual marking of the KNX Push-button Pros.

In KNX, to be completed with: KNX Push-button Pro System Design MTN6180-60..

System Design MTN6181-6035

Contents: 3 prefabricated foils and 24 different individual symbols with 1 carrier foil.



Dismantling protection



Version	Art. no.	
	MTN6270-0000	New

Prevents the KNX Push-button Pro and the KNX Multi-Touch Pro from being removed easily.

In KNX, to be completed with: KNX Push-button Pro System M MTN6180-04..

System Design MTN6180-60..

System Design MTN6181-6035

KNX Multitouch Pro System M MTN6215-03..

System Design MTN6215-59..

System Design MTN6216-5910

Contents: 2 stainless steel hooks.

Push-button



KNX Multitouch Pro



Version

Art. no.

MTN6215-5910

New

For System Design.

Comfortable room controller for controlling up to 32 room functions and the room temperature. All functions are displayed on a touch screen and are called up using simple finger movements. The user chooses from 3 interface designs that can be freely assigned to the room functions. The room temperature control can be shown in 2 different designs.

With room temperature control unit, display and connection for the remote sensor.

The room temperature control unit can be used for heating and cooling with infinitely adjustable KNX valve drives or to trigger switch actuators and heating actuators.

ETS device functions:

- Switch-on behaviour of the user interface
- Proximity function: The display and the start screen only become visible when approached
- Gesture function: The device recognises a gesture (horizontal or vertical swipe movement) and triggers a function. In this way, the light can be switched on when you enter the room, for example.
- Cleaning mode: For a specific period of time, neither touches nor gestures are detected
- Adjusting the background lighting
- Setting the screen saver

With integrated bus coupler. The bus is connected using a bus connecting terminal.

KNX software functions:

Control unit/push-button:

Switching, toggling, dimming (single/dual-surface), blind (single/dual-surface), pulse edges trigger 1-, 2-, 4- or 8-bit telegrams, pulse edges with 2-byte telegrams, 8-bit linear regulator, scene retrieval, scene saving, signal function, fan control, operating modes, setpoint adjustment

Functions of the room temperature control unit:

Controller type: 2-step controller, continuous-action PI control, switching PI control (PWM)

Output: continuous in the range 0 to 100% or switching ON/OFF

Controller mode:

- Heating with one controller output
- Cooling with one controller output
- Heating and cooling with separate controller outputs
- 2-step heating with 2 control outputs
- 2-step cooling with 2 control outputs
- 2-step heating and cooling with 4 control outputs

Operating modes: Comfort, comfort extension, standby (ECO), night reduction, frost/heat protection

Move all setpoints. Save all setpoint temperatures and operating modes when reset. External temperature monitoring. Additional output of the control value as 1 byte value on the PWM.

Signal function for the actual temperature, valve protection function.

Scene function.

Operation: Touch display

Accessories: Dismantling protection MTN6270-0000

Remote sensor for universal room temperature control unit with touch display MTN5775-0003

Fixing frame for 3-module box MTN6270-0015

D-Life frame, 1-gang, for 3-module box MTN6010-65xx

Note: Programmable with ETS4 and higher.

Contents: With bus connecting terminal and supporting plate.

Push-button



KNX Multitouch Pro



Version	Art. no.
	MTN6216-5910 New

For the Danish market.

For System Design.
 Comfortable room controller for controlling up to 32 room functions and the room temperature. All functions are displayed on a touch screen and are called up using simple finger movements. The user chooses from 3 interface designs that can be freely assigned to the room functions. The room temperature control can be shown in 2 different designs.
 With room temperature control unit, display and connection for the remote sensor.
 The room temperature control unit can be used for heating and cooling with infinitely adjustable KNX valve drives or to trigger switch actuators and heating actuators.

ETS device functions:

- Switch-on behaviour of the user interface
- Proximity function: The display and the start screen only become visible when approached
- Gesture function: The device recognises a gesture (horizontal or vertical swipe movement) and triggers a function. In this way, the light can be switched on when you enter the room, for example.
- Cleaning mode: For a specific period of time, neither touches nor gestures are detected
- Adjusting the background lighting
- Setting the screen saver

With integrated bus coupler. The bus is connected using a bus connecting terminal.
 With fixing frame for DK-Fuga wall box.

KNX software functions:

Control unit/push-button:

Switching, toggling, dimming (single/dual-surface), blind (single/dual-surface), pulse edges trigger 1-, 2-, 4- or 8-bit telegrams, pulse edges with 2-byte telegrams, 8-bit linear regulator, scene retrieval, scene saving, signal function, fan control, operating modes, setpoint adjustment

Functions of the room temperature control unit:

Controller type: 2-step controller, continuous-action PI control, switching PI control (PWM)

Output: continuous in the range 0 to 100% or switching ON/OFF

Controller mode:

- Heating with one controller output
- Cooling with one controller output
- Heating and cooling with separate controller outputs
- 2-step heating with 2 control outputs
- 2-step cooling with 2 control outputs
- 2-step heating and cooling with 4 control outputs

Operating modes: Comfort, comfort extension, standby (ECO), night reduction, frost/heat protection

Move all setpoints. Save all setpoint temperatures and operating modes when reset. External temperature monitoring. Additional output of the control value as 1 byte value on the PWM.

Signal function for the actual temperature, valve protection function.

Scene function.

Operation: Touch display

Accessories: Dismantling protection MTN6270-0000

Remote sensor for universal room temperature control unit with touch display

MTN5775-0003

Note: Programmable with ETS4 and higher.

Contents: With fixing frame for DK-Fuga wall box.

With bus connecting terminal.

Remote sensor for universal room temperature control unit with touch display



Version	Art. no.
	MTN5775-0003 New

For use with underfloor heating systems.

To be completed with: Universal temperature control unit insert with touch display MTN5775-0000

Programmable universal temperature control unit insert with touch display MTN5776-0000

KNX Multitouch Pro System M MTN6215-03..

System Design MTN6215-59..

System Design MTN6216-5910



Push-button



Fixing frame for 3-module box



Version	Art. no.
	MTN6270-0015 New

Fixing frame for 3-module installation boxes.
 Plug the KNX devices together with the D-Life frame, 1-gang, for 3-module box on the fixing frame.
 Suitable for installation on 3-module boxes.
To be completed with: D-Life frame, 1-gang, for 3-module box System Design MTN6010-65xx



D-Life frame, 1-gang, for 3-module box



Version	Art. no.
<input type="checkbox"/> lotus white	MTN6010-6535 New
<input checked="" type="checkbox"/> anthracite	MTN6010-6534 New
<input type="checkbox"/> stainless steel	MTN6010-6536 New

Plug the KNX System Design devices together with the D-Life frame on the fixing frame for 3-module box.
 For horizontal and vertical installation.
To be completed with: Fixing frame for 3-module box MTN6270-0015

Push-button

Push-buttons Altira



KNX push-button 1-gang



Version	Art. no.
white	ALB45150 Discontinued
aluminium	ALB46150 Discontinued

2 modules
In Altira design.
KNX-push-button with 2 buttons and 2 blue status LEDs. The status LED is located under the symbol window which can be taken off.
With integrated bus coupler. The bus is connected using a bus connecting terminal.
KNX software functions: Switching, toggling, dimming (single/dual-surface), blind (single/dual-surface), pulse edges trigger 1-, 2-, 4- or 8-bit telegrams (distinction between short and long operation), pulse edges with 2-byte telegrams (distinction between short and long operation), 8-bit linear regulator, scene retrieval, scene saving, disable functions.
Contents: With set of 10 symbols: 2x symbol with light opening, 1x symbol "1", 1x symbol "0", 2x symbol for dimming, 2x symbol for shutter, 2x symbol (neutral).
With bus connecting terminal.

KNX push-button 2-gang



Version	Art. no.
white	ALB45151 Discontinued
aluminium	ALB46151 Discontinued

2 modules
In Altira design.
KNX-push-button with 4 buttons and 4 blue status LEDs. The status LED is located under the symbol window which can be taken off.
With integrated bus coupler. The bus is connected using a bus connecting terminal.
KNX software functions: Switching, toggling, dimming (single/dual-surface), blind (single/dual-surface), pulse edges trigger 1-, 2-, 4- or 8-bit telegrams (distinction between short and long operation), pulse edges with 2-byte telegrams (distinction between short and long operation), 8-bit linear regulator, scene retrieval, scene saving, disable functions.
Contents: With set of 20 symbols: 4x symbol with light opening, 2x symbol "1", 2x symbol "0", 4x symbol for dimming, 4x symbol for shutter, 4x symbol (neutral).
With bus connecting terminal.

KNX 1-gang push-button with IR receiver



Version	Art. no.
white	ALB45152 Discontinued
aluminium	ALB46152 Discontinued

2 modules
In Altira design.
KNX-push-button with 2 buttons, blue status LED and IR receiver. The status LED is located under the symbol window which can be taken off.
The functions of each of the button can be triggered using an IR remote control.
The push-button is pre-programmed for operation with a Schneider-Electric IR remote control Distance. Many other IR remote controls (e.g. existing TV or CD player remote controls) can be taught into the push-buttons.
With integrated bus coupler. The bus is connected using a bus connecting terminal.
KNX software functions: Switching, toggling, dimming (single/dual-surface), blind (single/dual-surface), pulse edges trigger 1-, 2-, 4- or 8-bit telegrams (distinction between short and long operation), pulse edges with 2-byte telegrams (distinction between short and long operation), 8-bit linear regulator, scene retrieval, scene saving, disable functions.
Transmitter: IR universal remote control MTN5761-0000
Contents: With bus connecting terminal.

Push-buttons Unica

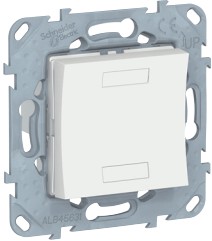

KNX push-button single



Version	Art. no.	
<input type="checkbox"/> white	NU553018	New
<input type="checkbox"/> white, antibacterial	NU553020	New
<input checked="" type="checkbox"/> aluminium	NU553030	New
<input checked="" type="checkbox"/> anthracite	NU553054	New

2 modules

In Unica design.

KNX-push-button with 1 rocker (2 buttons) and 2 blue status LEDs. The status LED is located under the symbol window which can be taken off.

With integrated bus coupler. The bus is connected using a bus connecting terminal.

KNX software functions: Switching, toggling, dimming (single/dual-surface), blind (single/dual-surface), pulse edges trigger 1-, 2-, 4- or 8-bit telegrams (distinction between short and long operation), pulse edges with 2-byte telegrams (distinction between short and long operation), 8-bit linear regulator, scene retrieval, scene saving, disable functions.

Contents: With set of 10 symbols: 2x symbol with light opening, 1x symbol "1", 1x symbol "0", 2x symbol for dimming, 2x symbol for shutter, 2x symbol (neutral).

With bus connecting terminal.



KNX push-button double



Version	Art. no.	
<input type="checkbox"/> white	NU553118	New
<input type="checkbox"/> white, antibacterial	NU553120	New
<input checked="" type="checkbox"/> aluminium	NU553130	New
<input checked="" type="checkbox"/> anthracite	NU553154	New

2 modules

In Unica design.

KNX-push-button with 2 rockers (4 buttons) and 4 blue status LEDs. The status LED is located under the symbol window which can be taken off.

With integrated bus coupler. The bus is connected using a bus connecting terminal.

KNX software functions: Switching, toggling, dimming (single/dual-surface), blind (single/dual-surface), pulse edges trigger 1-, 2-, 4- or 8-bit telegrams (distinction between short and long operation), pulse edges with 2-byte telegrams (distinction between short and long operation), 8-bit linear regulator, scene retrieval, scene saving, disable functions.

Contents: With set of 20 symbols: 4x symbol with light opening, 2x symbol "1", 2x symbol "0", 4x symbol for dimming, 4x symbol for shutter, 4x symbol (neutral).

With bus connecting terminal.

Push-button

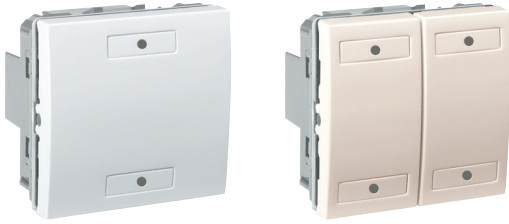

KNX push-button 1-gang



Version	Art. no.
<input type="checkbox"/> white	MGU3.530.18
<input type="checkbox"/> ivory	MGU3.530.25

2 modules
In Unica design.
KNX-push-button with 2 buttons and 2 blue status LEDs. The status LED is located under the symbol window which can be taken off.
With integrated bus coupler. The bus is connected using a bus connecting terminal.
KNX software functions: Switching, toggling, dimming (single/dual-surface), blind (single/dual-surface), pulse edges trigger 1-, 2-, 4- or 8-bit telegrams (distinction between short and long operation), pulse edges with 2-byte telegrams (distinction between short and long operation), 8-bit linear regulator, scene retrieval, scene saving, disable functions.
Contents: With set of 10 symbols: 2x symbol with light opening, 1x symbol "1", 1x symbol "0", 2x symbol for dimming, 2x symbol for shutter, 2x symbol (neutral).
With bus connecting terminal.

KNX push-button 2-gang



Version	Art. no.
<input type="checkbox"/> white	MGU3.531.18
<input type="checkbox"/> ivory	MGU3.531.25

2 modules
In Unica design.
KNX-push-button with 4 buttons and 4 blue status LEDs. The status LED is located under the symbol window which can be taken off.
With integrated bus coupler. The bus is connected using a bus connecting terminal.
KNX software functions: Switching, toggling, dimming (single/dual-surface), blind (single/dual-surface), pulse edges trigger 1-, 2-, 4- or 8-bit telegrams (distinction between short and long operation), pulse edges with 2-byte telegrams (distinction between short and long operation), 8-bit linear regulator, scene retrieval, scene saving, disable functions.
Contents: With set of 20 symbols: 4x symbol with light opening, 2x symbol "1", 2x symbol "0", 4x symbol for dimming, 4x symbol for shutter, 4x symbol (neutral).
With bus connecting terminal.

KNX 1-gang push-button with IR receiver



Version	Art. no.
<input type="checkbox"/> white	MGU3.532.18
<input type="checkbox"/> ivory	MGU3.532.25

2 modules
In Unica design.
KNX-push-button with 2 buttons, blue status LED and IR receiver. The status LED is located under the symbol window which can be taken off.
The functions of each of the button can be triggered using an IR remote control.
The push-button is pre-programmed for operation with a Schneider-Electric IR remote control Distance. Many other IR remote controls (e.g. existing TV or CD player remote controls) can be taught into the push-buttons.
With integrated bus coupler. The bus is connected using a bus connecting terminal.
KNX software functions: Switching, toggling, dimming (single/dual-surface), blind (single/dual-surface), pulse edges trigger 1-, 2-, 4- or 8-bit telegrams (distinction between short and long operation), pulse edges with 2-byte telegrams (distinction between short and long operation), 8-bit linear regulator, scene retrieval, scene saving, disable functions.
Transmitter: IR universal remote control MTN5761-0000
Contents: With bus connecting terminal.

Push-button

Push-buttons Unica Top

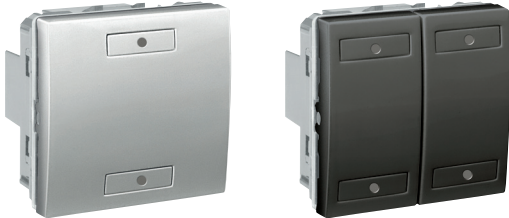

KNX push-button 1-gang



Version	Art. no.
■ aluminium	MGU3.530.30
■ graphite	MGU3.530.12

2 modules
In Unica Top design.
KNX-push-button with 2 buttons and 2 blue status LEDs. The status LED is located under the symbol window which can be taken off.
With integrated bus coupler. The bus is connected using a bus connecting terminal.
KNX software functions: Switching, toggling, dimming (single/dual-surface), blind (single/dual-surface), pulse edges trigger 1-, 2-, 4- or 8-bit telegrams (distinction between short and long operation), pulse edges with 2-byte telegrams (distinction between short and long operation), 8-bit linear regulator, scene retrieval, scene saving, disable functions.
Contents: With set of 10 symbols: 2x symbol with light opening, 1x symbol "1", 1x symbol "0", 2x symbol for dimming, 2x symbol for shutter, 2x symbol (neutral).
With bus connecting terminal.

KNX push-button 2-gang



Version	Art. no.
■ aluminium	MGU3.531.30
■ graphite	MGU3.531.12

2 modules
In Unica Top design.
KNX-push-button with 4 buttons and 4 blue status LEDs. The status LED is located under the symbol window which can be taken off.
With integrated bus coupler. The bus is connected using a bus connecting terminal.
KNX software functions: Switching, toggling, dimming (single/dual-surface), blind (single/dual-surface), pulse edges trigger 1-, 2-, 4- or 8-bit telegrams (distinction between short and long operation), pulse edges with 2-byte telegrams (distinction between short and long operation), 8-bit linear regulator, scene retrieval, scene saving, disable functions.
Contents: With set of 20 symbols: 4x symbol with light opening, 2x symbol "1", 2x symbol "0", 4x symbol for dimming, 4x symbol for shutter, 4x symbol (neutral).
With bus connecting terminal.

KNX 1-gang push-button with IR receiver





Version	Art. no.
■ aluminium	MGU3.532.30
■ graphite	MGU3.532.12

2 modules
In Unica Top design.
KNX-push-button with 2 buttons, blue status LED and IR receiver. The status LED is located under the symbol window which can be taken off.
The functions of each of the button can be triggered using an IR remote control.
The push-button is pre-programmed for operation with a Schneider-Electric IR remote control Distance. Many other IR remote controls (e.g. existing TV or CD player remote controls) can be taught into the push-buttons.
With integrated bus coupler. The bus is connected using a bus connecting terminal.
KNX software functions: Switching, toggling, dimming (single/dual-surface), blind (single/dual-surface), pulse edges trigger 1-, 2-, 4- or 8-bit telegrams (distinction between short and long operation), pulse edges with 2-byte telegrams (distinction between short and long operation), 8-bit linear regulator, scene retrieval, scene saving, disable functions.
Transmitter: IR universal remote control MTN5761-0000
Contents: With bus connecting terminal.

Push-button



KNX

Overview binary inputs

	Push-button interface plus		Binary input REG-K/x10	
				
Article number	MTN670802	MTN670804	MTN644492	MTN644592
Number of channels	2	4	4	8
Outputs	2 (only for low-current LEDs)	4 (only for low-current LEDs)	—	—
Device width	40x30.5x12.5 mm (LxWxH)		2.5 modules	4 modules
Use cases	Connection of conventional push-buttons or floating contacts		Connection of conventional push-buttons or floating contacts	
Installation site	In the vicinity of push-buttons		Cabinet	
Connecting terminal	—		Plug-in screw terminals	
Internally generated voltage	■		■	
Input voltage / Contact voltage	— / 3.5 V		— / 10 V	
Input current / Contact current	— / 2 mA		— / 2 mA	
Thresholds	—		—	
Maximum line length	7.5 m		50 m	
Software				
Toggle	■		■	
Switching	■		■	
Dimming (via one/two inputs)	■		■	
Blind (via one/two inputs)	■		■	
Blind with position values	■		■	
Edges (1 bit, 2 bit, 4 bit, 1 byte, 2 byte)	■		■	
Edges (1 bit, 2 bit, 4 bit, 1 byte, 2 byte) short and long operation	■		■	
8 bit slider	■		■	
Scenes	■		■	
Pulse counter	■		■	
Switch counter	■		■	
Reset counter	■		■	
Cyclical sending (1 bit, 2 bit, 1 byte)	■		■	
Locking function for each channel	■		■	
Locking function	■		■	
■ Adjustable for each channel	■		■	
■ All channels follow the function of a master channel	■		■	

KNX

Overview binary inputs

Binary input REG-K/x24		Binary input REG-K/x230	
			
MTN644892	MTN644792	MTN644992	MTN644692
4	8	4	8
—	—	—	—
2.5 modules	4 modules	2,5 modules	4 modules
Connection of conventional devices with AC / DC 24 V outputs, for example, window contacts, wind sensors, glass break sensors		Connection of conventional devices with AC 230 V outputs	
Cabinet		Cabinet	
Plug-in screw terminals		Plug-in screw terminals	
—		—	
AC/DC 24 V / —		AC 230 V / —	
AC 6 mA, DC 15 mA / —		AC 12 mA / —	
0 signal: $\leq 5\text{ V}$ 1 signal: $\geq 11\text{ V}$		0 signal: $\leq 40\text{ V}$ 1 signal: $\geq 160\text{ V}$	
100 m		100 m	
	■		■
	■		■
	■		■
	■		■
	■		■
	■		■
	■		■
	■		■
	■		■
	■		■
	■		■
	■		■
	■		■
	■		■
	■ ■		■ ■

Binary inputs



Push-button interface, 2-gang plus



Version	Art. no.
polar white	MTN670802

Generates an internal signal voltage for connecting two conventional push-buttons or floating contacts, and for direct connecting two low-current LEDs. The cores are 30 cm long and can be extended to max. 7.5 m. For installation in a conventional 60 mm switch box.

KNX software functions: Switching, dimming or controlling blinds via 1 or 2 inputs, position values for blind control (8-bit), pulse edges with 1-, 2-, 4-, or 8-bit telegrams, differentiation between short and long activation, initialisation telegram, cyclical transmission, pulse edges with 2-byte telegrams, 8-bit linear regulator, scenes, counter, disable function, break contact/ make contact, debounce time. Outputs for connecting control lamps (low-current LEDs) for the status display.

For each input/output object type:

Contact voltage: < 3 V (SELV)

Contact current: < 0.5 mA

Output current: max. 2 mA

Max. cable length: 30 cm unshielded, can be extended up to max. 7.5 m with twisted unshielded cable.

Dimensions: approx. 40x30.5x12.5 mm (LxWxH)



Push-button interface, 4-gang plus



Version	Art. no.
polar white	MTN670804

Generates an internal signal voltage for connecting four conventional push-buttons or floating contacts, and for direct connecting four low-current LEDs. The cores are 30 cm long and can be extended to max. 7.5 m. For installation in a conventional 60 mm switch box.

KNX software functions: Switching, dimming or controlling blinds via 1 or 2 inputs, position values for blind control (8-bit), pulse edges with 1-, 2-, 4-, or 8-bit telegrams, differentiation between short and long activation, initialisation telegram, cyclical transmission, pulse edges with 2-byte telegrams, 8-bit linear regulator, scenes, counter, disable function, break contact/ make contact, debounce time. Outputs for connecting control lamps (low-current LEDs) for the status display.

For each input/output object type:

Contact voltage: < 3 V (SELV)

Contact current: < 0.5 mA

Output current: max. 2 mA

Max. cable length: 30 cm unshielded, can be extended up to max. 7.5 m with twisted unshielded cable.

Dimensions: approx. 40x30.5x12.5 mm (LxWxH)

Binary inputs



Binary input REG-K/4x10



Version	Art. no.
---------	----------

light grey	MTN644492
------------	------------------

For connecting four conventional push-buttons or floating contacts to the KNX. Internally generates a signal voltage SELV, electrically isolated from the bus. With integrated bus coupler and plug-in screw terminals. The input voltage level is displayed at each input with a yellow LED. A green LED indicates that the device is ready for operation once the application has been loaded. For installation on DIN rails TH35 according to EN 60715. The bus is connected using a bus connecting terminal; a data rail is not necessary.

KNX software functions: Switching, dimming or blind control via 1 or 2 inputs. Positioning values for blind control (8-bit). Pulse edges with 1-, 2-, 4-, or 8-bit telegrams. Differentiation between short/long operation. Initialisation telegram. Cyclical sending. Pulse edges with 2-byte telegrams. 8-bit linear regulator. Disable function. Break/make contact. Debounce time.

Inputs: 4
Contact voltage: max. 10 V, clocked
Contact current: max. 2 mA, pulsing
Cable length: max. 50 m
Device width: 2.5 modules = approx. 45 mm
Contents: With bus connecting terminal and cable cover.



Binary input REG-K/8x10



Version	Art. no.
---------	----------

light grey	MTN644592
------------	------------------

For connecting eight conventional push-buttons or floating contacts to the KNX. Internally generates a signal voltage SELV, electrically isolated from the bus. With integrated bus coupler and plug-in screw terminals. The input voltage level is displayed at each input with a yellow LED. A green LED indicates that the device is ready for operation once the application has been loaded. For installation on DIN rails TH35 according to EN 60715. The bus is connected using a bus connecting terminal; a data rail is not necessary.

KNX software functions: Switching, dimming or blind control via 1 or 2 inputs. Positioning values for blind control (8-bit). Pulse edges with 1-, 2-, 4-, or 8-bit telegrams. Differentiation between short/long operation. Initialisation telegram. Cyclical sending. Pulse edges with 2-byte telegrams. 8-bit linear regulator. Disable function. Break/make contact. Debounce time.

Inputs: 8
Contact voltage: max. 10 V, clocked
Contact current: max. 2 mA, pulsing
Cable length: max. 50 m
Device width: 4 modules = approx. 70 mm
Contents: With bus connecting terminal and cable cover.

Binary inputs



Binary input REG-K/4x24



Version	Art. no.
light grey	MTN644892

For connecting four conventional devices with AC/DC 24 V outputs to the KNX. With integrated bus coupler and plug-in screw terminals. The input voltage level is displayed at each input with a yellow LED. A green LED indicates that the device is ready for operation once the application has been loaded. For installation on DIN rails TH35 according to EN 60715. The bus is connected using a bus connecting terminal; a data rail is not necessary.

KNX software functions: Switching, dimming or blind control via 1 or 2 inputs. Positioning values for blind control (8-bit). Pulse edges with 1-, 2-, 4-, or 8-bit telegrams. Differentiation between short/long operation. Initialisation telegram. Cyclical sending. Pulse edges with 2-byte telegrams. 8-bit linear regulator. Disable function. Break/make contact. Debounce time.

Input voltage: AC / DC 24 V
Inputs: 4
Input current: DC 15 mA (30 V), AC 6 mA (27 V)
0 signal: ≤ 5 V
1 signal: ≥ 11 V
Cable length: max. 100 m
Device width: 2.5 modules = approx. 45 mm
Accessories: Power supply REG, 24 V DC / 0.4 A MTN693003, Power supply REG, AC 24 V/1 A MTN663529
Contents: With bus connecting terminal and cable cover.



Binary input REG-K/8x24



Version	Art. no.
light grey	MTN644792

For connecting 8 conventional devices with AC/DC 24 V outputs to KNX. With integrated bus coupler and plug-in screw terminals. The input voltage level is displayed at each input with a yellow LED. A green LED indicates that the device is ready for operation once the application has been loaded. For installation on DIN rails TH35 according to EN 60715. The bus is connected using a bus connecting terminal; a data rail is not necessary.

KNX software functions: Switching, dimming or blind control via 1 or 2 inputs. Positioning values for blind control (8-bit). Pulse edges with 1-, 2-, 4-, or 8-bit telegrams. Differentiation between short/long operation. Initialisation telegram. Cyclical sending. Pulse edges with 2-byte telegrams. 8-bit linear regulator. Disable function. Break/make contact. Debounce time.

Input voltage: AC/DC 24V
Inputs: 8
Input current: DC approx. 15 mA/AC approx. 6 mA
Line length: max. 100 m
Device width: 4 modules = approx. 72 mm
Accessories: Power supply REG, 24 V DC / 0.4 A MTN693003, Power supply REG, AC 24 V/1 A MTN663529
Contents: With bus connecting terminal and cable cover.

Binary inputs



Binary input REG-K/4x230



Version	Art. no.
light grey	MTN644992

For connecting four conventional devices with AC 230 V outputs to the KNX. With integrated bus coupler and plug-in screw terminals. The input voltage level is displayed at each input with a yellow LED. A green LED indicates that the device is ready for operation once the application has been loaded. For installation on DIN rails TH35 according to EN 60715. The bus is connected using a bus connecting terminal; a data rail is not necessary.

KNX software functions: Switching, dimming or blind control via 1 or 2 inputs. Positioning values for blind control (8-bit). Pulse edges with 1-, 2-, 4-, or 8-bit telegrams. Differentiation between short/long operation. Initialisation telegram. Cyclical sending. Pulse edges with 2-byte telegrams. 8-bit linear regulator. Disable function. Break/make contact. Debounce time.

Input voltage: AC 230 V, 50-60Hz
Inputs: 4
Input current: AC 12 mA
0 signal: ≤ 40 V
1 signal: ≥ 160 V
Cable length: max. 100 m
Device width: 2.5 modules = approx. 45 mm
Contents: With bus connecting terminal and cable cover.



Binary input REG-K/8x230



Version	Art. no.
light grey	MTN644692



For connecting eight conventional devices with AC 230 V outputs to the KNX. With integrated bus coupler and plug-in screw terminals. The input voltage level is displayed at each input with a yellow LED. A green LED indicates that the device is ready for operation once the application has been loaded. For installation on DIN rails TH35 according to EN 60715. The bus is connected using a bus connecting terminal; a data rail is not necessary.

KNX software functions: Switching, dimming or blind control via 1 or 2 inputs. Positioning values for blind control (8-bit). Pulse edges with 1-, 2-, 4-, or 8-bit telegrams. Differentiation between short/long operation. Initialisation telegram. Cyclical sending. Pulse edges with 2-byte telegrams. 8-bit linear regulator. Disable function. Break/make contact. Debounce time.

Input voltage: AC 230V, 50-60Hz
Inputs: 8
Input current: AC approx. 7 mA
Line length: max. 100 m
Device width: 4 modules = approx. 72 mm
Contents: With bus connecting terminal and cable cover.

KNX

Overview presence detectors and movement detectors

	KNX ARGUS Presence Basic	KNX ARGUS Presence	KNX ARGUS Presence with light control and IR receiver	
				
Article number	MTN6307..	MTN6308..	MTN6309..	
Design	—	—	—	
Use cases (examples)	Offices, waiting rooms Lighting, heating control	Large offices, waiting rooms, classrooms, private areas, public buildings Lighting, blinds, heating control	Large offices, waiting rooms, classrooms, private areas, public buildings Lighting, blinds, heating control, constant light control	
Installation site	Ceiling mounting, indoor	Ceiling mounting, indoor	Ceiling mounting, indoor	
Protection type	IP 20	IP 20	IP 20	
Recommended mounting height	2.5 m	2.5 m	2.5 m	
Angle of detection	360°	360°	360°	
Range (right, left / front)	7 m radius	7 m radius	7 m radius	
Number of levels	6	6	6	
Number of zones	136	136	136	
Number of switching segments	544	544	544	
Number of movement sensors	4	4	4	
Light sensor	10-2000 Lux	10-2000 Lux	10-2000 Lux	
Staircase timer adjustable on the device	—	—	—	
Staircase timer adjustable in the ETS	1 s - 255 h	1 s - 255 h	1 s - 255 h	
Software				
Light regulation for a permanent desired brightness	—	—	■	
Number of movement/presence blocks	2	5	5+1 (1 for light control)	
Number of functions per block	4	4	4	
Functions per block				
■ Output telegrams 1 bit, 1 byte, 2 byte	■	■	■	
■ Staircase timer	■	■	■	
■ Self-adjusting staircase timer	■	■	■	
■ Sensitivity adjustable	■	■	■	
■ Range adjustable	■	■	■	
■ Brightness threshold	■	■	■	
■ Locking function	■	■	■	
■ Sensitivity and range of the movement sensors sector-specifically adjustable	—	■	■	
Brightness value correction	—	■	■	
Cyclical sending of the determined brightness value	■	■	■	
Cyclical sending of brightness value via 2 bytes object	■	■	■	
Brightness threshold adjustable via object	—	■	■	
Master/Slave function	—	■	■	
Monitoring function (cyclical sending)	—	■	■	
Dead time adjustable (noise reduction)	—	—	—	
IR receiver up to 10 channels				
■ IR functions with KNX telegrams	—	—	■	
■ Configuration of brightness threshold, staircase timer and range	—	—	■	



KNX

Overview presence detectors and movement detectors

	KNX ARGUS Presence 180/2,20 m, flush-mounted	KNX ARGUS 180/2,20 m, flush-mounted	KNX ARGUS 180, flush-mounted	KNX ARGUS 220
	MTN6304.., MTN6306..	MTN6317.., MTN6327..	MTN6316.., MTN6326..	MTN6325..
	System M MTN6302-60.. System Design	System M	System M	—
	Large offices, waiting rooms, classrooms, private areas, public buildings Lighting, blinds, heating control	Corridors, private areas, public buildings Lighting, blinds, heating control	Corridors, private areas, public areas with limited access Lighting, blinds, heating control	Entrance areas, patios, garages, large-scale indoor areas where devices with a protection type higher IP20 are required (working rooms, wellness centres, ...) Lighting
	Flush mounting, indoor	Flush mounting, indoor	Flush mounting, indoor	Surface mounting, outdoor, indoor
	IP 20	IP 20	IP 20	IP 55
	2.2 m oder 1.1 m (halved range)	2.2 m oder 1.1 m (halved range)	1.10 m	2.5 m
	180°	180°	180°	220°, adjustable lense
	8 m right/left, 12 m to the front	8 m right/left, 12 m to the front	8 m radius	14 m right/left, 16 m to the front
	6	6	1	7
	46	46	14	112
	—	—	—	448
	2	2	1	1
	10-2000 Lux	10-2000 Lux	10-2000 Lux	3-2000 Lux
	1 s - 8 min	1 s - 8 min	1 s - 8 min	1 s - 8 min
	1 s - 255 h	1 s - 255 h	1 s - 255 h	1 s - 255 h
	—	—	—	—
	5	5	5	5
	4	4	4	4
				—
		—	—	—
		—	—	—
	—			
	—	—	—	—
	—	—	—	—



KNX

Overview presence detectors and movement detectors

	KNX Movement detector 180	
		
Article number	MGU3.533.18/25	MGU5.533.18/25
Design	Unica	
Use cases (examples)	Corridors, private areas, public areas with limited access Lighting, blinds, heating control	
Installation site	Flush mounting, indoor	
Protection type	IP 20	
Recommended mounting height	1.10 m	
Angle of detection	180°	
Range (right, left / front)	8 m Radius	
Number of levels	1	
Number of zones	14	
Number of switching segments	—	
Number of movement sensors	1	
Light sensor	10-2000 Lux	
Staircase timer adjustable on the device	1 s - 8 min	
Staircase timer adjustable in the ETS	1 s - 255 h	
Software		
Light regulation for a permanent desired brightness	—	
Number of movement/presence blocks	5	
Number of functions per block	4	
Functions per block	<ul style="list-style-type: none"> ■ Output telegrams 1 bit, 1 byte, 2 byte ■ Staircase timer ■ Self-adjusting staircase timer ■ Sensitivity adjustable ■ Range adjustable ■ Brightness treshold ■ Locking function ■ Sensitivity and range of the movement sensors sector-specifically adjustable 	
Brightness value correction	■	
Cyclical sending of the determined brightness value	—	
Cyclical sending of brightness value via 2 bytes object	■	
Brightness threshold adjustable via object	—	
Master/Slave function	■	
Monitoring function (cyclical sending)	■	
Dead time adjustable (noise reduction)	■	
IR receiver up to 10 channels		
<ul style="list-style-type: none"> ■ IR functions with KNX telegrams ■ Configuration of brightness treshold, staircase timer and range 	—	

KNX

Overview presence detectors and movement detectors

KNX Movement detector 180		KNX Movement detector 180	
			
MGU3.533.30/12	MGU5.533.30/12		ALB45153, ALB46153
Unica Top		Altira	
Corridors, private areas, public areas with limited access		Corridors, private areas, public areas with limited access	
Lighting, blinds, heating control		Lighting, blinds, heating control	
Flush mounting, indoor		Flush mounting, indoor	
IP 20		IP 20	
1.10 m		1.10 m	
180°		180°	
8 m Radius		8 m radius	
1		1	
14		14	
—		—	
1		1	
10-2000 Lux		10-2000 Lux	
1 s - 8 min		1 s - 8 min	
1 s - 255 h		1 s - 255 h	
—		—	
5		5	
4		4	
■		■	
■		■	
■		■	
■		■	
■		■	
■		■	
■		■	
■		■	
■		■	
■		■	
■		■	
■		■	
—		—	
—		—	

Movement detector

Movement detectors



KNX ARGUS 220



Version	Art. no.
polar white	MTN632519
dark brazil	MTN632515
aluminium	MTN632569

KNX movement detector for outdoors. 220° surface monitoring for large house fronts and sections of the house. With integrated bus coupler. The physical address is programmed with a magnet.

- 360° short-range zone (approx. 4 m radius).
- Large wiring compartment and plug system.
- Looping is possible.
- LED function display for fast alignment at the installation site.
- Operating elements are protected under the easily accessible cover plate.
- Flexibly adjustable sensor head.
- Possible to blank out individual lens areas.

Can be installed on walls and ceilings without additional accessories. Can be mounted on inner/outer corners and stationary pipes using a mounting bracket.

KNX software functions: Five movement blocks: up to four functions can be triggered per block. Telegrams: 1 bit, 1 byte, 2 bytes.

Normal operation, master, slave, safety pause, disable function. Sensitivity, brightness and staircase timer can be set using the ETS or the potentiometer. Self-adjusting staircase timer.

Angle of detection: 220°

Range: max. 16 m

Number of levels: 7

Number of zones: 112 with 448 switching segments

Light sensor: infinitely variable from approx. 3 - 1000 lux, ∞ lux (infinite: movement detection is independent of the position of the sensor head)

Time: can be set externally from 1 s to approx. 8 min. in 6 levels or via ETS from approx. 3 s to approx. 152 hours

Sensitivity: infinitely adjustable

Possible settings for sensor head:

Wall mounting: 9° up, 24° down, 12° left/right, ±12° axial

Ceiling mounting: 4° up, 29° down, 25° left/right, ±8.5° axial

EC directives: Low-voltage guideline 2006/95/EC and EMC directive 2004/108/EC

Type of protection: IP 55

Accessories: Mounting bracket MTN565291, Programming magnet MTN639190

Contents: With cover plate and segments to limit the area of detection, screws and plugs.



Programming magnet



Version	Art. no.
	MTN639190

Non-contact programming of the physical address of the KNX ARGUS 220.

In KNX, to be completed with: KNX ARGUS 220 MTN6325..

Movement detector

Movement detectors System M

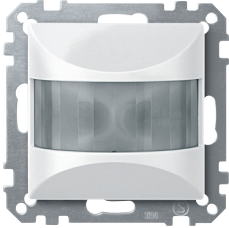

KNX ARGUS 180, flush-mounted



Version	Art. no.
<input checked="" type="checkbox"/> white, glossy	MTN631644
<input type="checkbox"/> polar white, glossy	MTN631619
<input type="checkbox"/> active white, glossy	MTN631625
<input checked="" type="checkbox"/> anthracite	MTN632614
<input checked="" type="checkbox"/> aluminium	MTN632660

For System M.
 Movement detector for indoors.
 When a movement is detected, a data telegram defined by the programming is transmitted.
 With integrated bus coupling unit.
KNX software functions: Five movement blocks: up to four functions can be triggered per block. Telegrams: 1 bit, 1 byte, 2 bytes. Normal operation, master, slave, safety pause, disable function. Sensitivity, brightness and staircase timer can be set using the ETS or the potentiometer. Self-adjusting staircase timer.
Angle of detection: 180°
Range: 8 m (for mounting height of 1.1 m)
Number of levels: 1
Number of zones: 14
Sensitivity: infinitely adjustable (ETS or potentiometer)
Light sensor: infinitely adjustable from approx. 10 to 2000 Lux (ETS or potentiometer)
Time: adjustable in steps from 1 s to 8 min (potentiometer) or adjustable from 1 s to 255 hours (ETS)
EC Directives: Low-voltage guideline 2006/95/EC and EMC guideline 2004/108/EC
Contents: With bus connecting terminal and supporting plate.

KNX ARGUS 180/2.20 m flush-mounted



Version	Art. no.
<input checked="" type="checkbox"/> white, glossy	MTN631744
<input type="checkbox"/> polar white, glossy	MTN631719
<input type="checkbox"/> active white, glossy	MTN631725
<input checked="" type="checkbox"/> anthracite	MTN632714
<input checked="" type="checkbox"/> aluminium	MTN632760

For System M.
 Indoor movement detector with anti-crawl protection.
 When a movement is detected, a data telegram defined by the programming is transmitted.
 With integrated bus coupling unit. For wall mounting in a size 60 mounting box, optimal installation at 2.2 m.
KNX software functions: Five movement blocks: up to four functions can be triggered per block. Telegrams: 1 bit, 1 byte, 2 bytes. Normal operation, master, slave, safety pause, disable function. Sensitivity, brightness and staircase timer can be set using the ETS or the potentiometer. Two movement sensors: the sensitivity and range can be set separately for each sensor. Self-adjusting staircase timer.
Angle of detection: 180°
Range: 8 m right/left, 12 m to the front (for a mounting height of 2.20 m)
Mounting height: 2.2 m or 1.1 m with half the range
Number of levels: 6
Number of zones: 46
Number of movement sensors: 2, sector-orientated, adjustable
Sensitivity: infinitely adjustable (ETS or potentiometer)
Light sensor: infinitely adjustable from approx. 10 to 2000 Lux (ETS or potentiometer)
Time: adjustable in steps from 1 s to 8 min (potentiometer) or adjustable from 1 s to 255 hours (ETS)
EC Directives: Low-voltage guideline 2006/95/EC and EMC guideline 2004/108/EC
Contents: With bus connecting terminal and supporting plate.
 With cover segments to limit the area of detection.

Movement detector

Movement detectors System Design



KNX ARGUS Presence 180/2.20 m flush-mounted



Version	Art. no.
Thermoplastic	
<input type="checkbox"/> lotus white	MTN6302-6035
<input checked="" type="checkbox"/> anthracite	MTN6302-6034
<input type="checkbox"/> sahara	MTN6302-6033
<input type="checkbox"/> stainless steel	MTN6302-6036
<input type="checkbox"/> nickel metallic	MTN6302-6050
<input type="checkbox"/> champagne metallic	MTN6302-6051
<input type="checkbox"/> mocca metallic	MTN6302-6052

For System Design.

Presence detection indoors.

If KNX ARGUS Presence detects smaller movements in the room, data telegrams are transmitted via KNX to control the lighting, blind or heating at the same time.

When the lighting is controlled by brightness-dependent movement detection, the device constantly monitors the brightness in the room. If sufficient natural light is at hand, the device switches the artificial light off even if a person is present. The overshoot time can be adjusted using the ETS.

With integrated bus coupling unit. For wall mounting in a size 60 mounting box, optimal installation at 2.2 m. With anti-crawl protection.

KNX software functions: Five movement/presence blocks: up to four functions can be triggered per block. Telegrams: 1 bit, 1 byte, 2 bytes.

Normal operation, master, slave, monitoring, safety pause, disable function. Two movement sensors: the sensitivity and range can be set separately for each sensor. Self-adjusting staircase timer. Actual brightness value: can be detected via the internal and/or an external light sensor. Actual value correction.

Angle of detection: 180°

Range: 8 m right/left, 12 m to the front (for a mounting height of 2.20 m)

Mounting height: 2.2 m or 1.1 m at half the range

Time: adjustable in steps from 1 s to 8 min (potentiometer) or adjustable from 1 s to 255 hours (ETS)

Number of levels: 6

Number of zones: 46

Number of movement sensors: 2, separately adjustable

Light sensor: internal light sensor infinitely adjustable from approx. 10 to 2000 Lux (ETS); external light sensor via KNX

EC Directives: Low-voltage guideline 2006/95/EC and EMC guideline 2004/108/EC

Accessories: Fixing frame for 3-module box MTN6270-0015

D-Life frame, 1-gang, for 3-module box MTN6010-65xx

Contents: With bus connecting terminal and supporting plate.

With cover segments to limit the area of detection.

Movement detector

Movement detectors Altira



KNX Movement detector 180



Version	Art. no.
<input type="checkbox"/> white	ALB45153
<input type="checkbox"/> aluminium	ALB46153

2 modules

Movement detector for indoors.

When a movement is detected, a data telegram defined by the programming is transmitted. With integrated bus coupler. The bus is connected using a bus connecting terminal.

KNX software functions: Five movement blocks: up to four functions can be triggered per block. Telegrams: 1 bit, 1 byte, 2 bytes.

Normal operation and surveillance operation, master, slave, safety pause, disable function. Sensitivity, brightness and staircase timer can be set using the ETS or the potentiometer. Two movement sensors: the sensitivity and range can be set separately for each sensor. Self-adjusting staircase timer.

Angle of detection: 180°

Number of movement sensors: 2, sector-orientated, adjustable (ETS)

Recommended mounting height: 1 m to 2,5 m

Range: at 2.15 m mounting height: Approx. 9 m on all sides, adjustable in 10 steps (rotary switch or ETS)

Detection brightness: Infinite setting from approx. 10 lux to approx.1000 lux (rotary switch) or from 10 lux to 2000 lux (ETS)

Overshoot time: Adjustable in 6 steps from approx. 1 s to approx. 8 min (rotary switch) or adjustable from 1 s to 255 hours (ETS)

EC guidelines: Low-voltage guideline 2006/95/EEC and EMC guideline 2004/108/EC

Contents: With bus connecting terminal.

Movement detectors Unica



KNX Movement detector 180



Version	Art. no.
<input type="checkbox"/> white	MGU3.533.18
<input type="checkbox"/> ivory	MGU3.533.25

2 modules

In Unica design.

Movement detector for indoors.

When a movement is detected, a data telegram defined by the programming is transmitted. With integrated bus coupler. The bus is connected using a bus connecting terminal.

KNX software functions: Five movement blocks: up to four functions can be triggered per block. Telegrams: 1 bit, 1 byte, 2 bytes.

Normal operation and surveillance operation, master, slave, safety pause, disable function. Sensitivity, brightness and staircase timer can be set using the ETS or the potentiometer. Two movement sensors: the sensitivity and range can be set separately for each sensor. Self-adjusting staircase timer.

Angle of detection: 180°

Number of movement sensors: 2, sector-orientated, adjustable (ETS)

Recommended mounting height: 1 m to 2,5 m

Range: at 2.15 m mounting height: Approx. 9 m on all sides, adjustable in 10 steps (rotary switch or ETS)

Detection brightness: Infinite setting from approx. 10 lux to approx.1000 lux (rotary switch) or from 10 lux to 2000 lux (ETS)

Overshoot time: Adjustable in 6 steps from approx. 1 s to approx. 8 min (rotary switch) or adjustable from 1 s to 255 hours (ETS)

EC guidelines: Low-voltage guideline 2006/95/EEC and EMC guideline 2004/108/EC

Contents: With bus connecting terminal.

Movement detector

Movement detectors Unica Top



KNX Movement detector 180



Version	Art. no.
■ aluminium	MGU3.533.30
■ graphite	MGU3.533.12

2 modules

In Unica Top design.

Movement detector for indoors.

When a movement is detected, a data telegram defined by the programming is transmitted.

With integrated bus coupler. The bus is connected using a bus connecting terminal.

KNX software functions: Five movement blocks: up to four functions can be triggered per block. Telegrams: 1 bit, 1 byte, 2 bytes.

Normal operation and surveillance operation, master, slave, safety pause, disable function.

Sensitivity, brightness and staircase timer can be set using the ETS or the potentiometer. Two movement sensors: the sensitivity and range can be set separately for each sensor. Self-adjusting staircase timer.

Angle of detection: 180°

Number of movement sensors: 2, sector-orientated, adjustable (ETS)

Recommended mounting height: 1 m to 2,5 m

Range: at 2.15 m mounting height: Approx. 9 m on all sides, adjustable in 10 steps (rotary switch or ETS)

Detection brightness: Infinite setting from approx. 10 lux to approx.1000 lux (rotary switch) or from 10 lux to 2000 lux (ETS)

Overshoot time: Adjustable in 6 steps from approx. 1 s to approx. 8 min (rotary switch) or adjustable from 1 s to 255 hours (ETS)

EC guidelines: Low-voltage guideline 2006/95/EEC and EMC guideline 2004/108/EC

Contents: With bus connecting terminal.

Movement detector

KNX presence detector



KNX High Bay presence detector FM



Version	Art. no.
white	MTN6304-0019 New

KNX presence detector for flush-mounted installation in rooms with high ceilings, e.g. high-bay warehouses or sports halls.

The presence detector detects the presence of persons even in the case of small movements. Control of the lighting is carried out dependent on movement (2 channels) or additionally dependent on brightness (1 channel) via KNX telegrams. If there is sufficient daylight, the lighting is switched off or adapted to a detection brightness (constant light regulation).

Devices for heating, ventilation or air conditioning (HVAC) can also be controlled (1 channel).

The presence detector has two detection sensors (passive infrared), a brightness sensor, an IR receiver and an LED to indicate a detected movement, in test mode indication of the activated programming mode.

The presence detector can be used as a single detector or in master-slave mode. The setting is carried out in the ETS.

The presence detector can also be set and tested without the ETS, but with the appropriate remote control (available as an accessory).

Indoor installation on ceiling (IP 20) on flush-mounted housing with two screws.

Optionally, a protective metal basket (available as an accessory) can be installed to protect the lens.

KNX software functions: Movement detection: The detected presence of a person is signalled using a KNX telegram. Lighting control: The room lighting is controlled depending on movement and brightness. If there is sufficient daylight, the lighting is switched off or dimmed to a constant level. Basic lighting: Activates basic lighting after the overtravel time has elapsed, either for a limited time or dependent on the brightness. HVAC control: Devices for heating, ventilation, air conditioning (HVAC) are switched from energy-saving mode to comfort mode dependent on movement. Operating modes: Single detector, Master, Slave, Master in parallel operation. Master: Controls the lighting and HVAC system. Additional detectors as slaves increase the area of detection. Slave: Only detects movement in its area and sends the information to the master. Master in parallel operation: Controls the lighting in its area (can be expanded with additional detectors as slaves). The only master in the installation only controls the HVAC system for the entire area. 2 logic gates

Angle of detection: 360°

Opening angle: 180°

Range: Radius of max. 18 m (tangential)

Mounting height: 4 - 14 m

Optimal mounting height: 12 m

Time setting: 60 s - 255 min.

Sensors: 2 x passive infrared

Number of zones: 1416

Detection brightness: internal light sensor adjustable from approx. 2 to 1000 Lux

IP protection rating: IP 20

EC guidelines: Low voltage directive 2006/95/EC and EMC directive 2004/108/EC

Dimensions: 124 x 78 mm (Ø x H)

Accessories: Remote control for KNX presence detector MTN6300-0002

Protective basket for KNX presence detector MTN6300-0001

Movement detector



KNX Corridor presence detector FM



Version	Art. no.	
white	MTN6305-0019	New

KNX presence detector for flush-mounted installation in long corridors. The presence detector detects the presence of persons even in the case of small movements. Control of the lighting is carried out dependent on movement (2 channels) or additionally dependent on brightness (1 channel) via KNX telegrams. If there is sufficient daylight, the lighting is switched off or adapted to a detection brightness (constant light regulation). Devices for heating, ventilation or air conditioning (HVAC) can also be controlled (1 channel). The presence detector has two detection sensors (passive infrared), a brightness sensor, an IR receiver and an LED to indicate a detected movement, in test mode indication of the activated programming mode. The presence detector can be used as a single detector or in master-slave mode. The setting is carried out in the ETS. The presence detector can also be set and tested without the ETS, but with the appropriate remote control (available as an accessory). Indoor installation on ceiling (IP 20) on flush-mounted housing with two screws.

Optionally, a protective metal basket (available as an accessory) can be installed to protect the lens.

KNX software functions: Movement detection: The detected presence of a person is signalled using a KNX telegram. Lighting control: The room lighting is controlled depending on movement and brightness. If there is sufficient daylight, the lighting is switched off or dimmed to a constant level. Basic lighting: Activates basic lighting after the overtravel time has elapsed, either for a limited time or dependent on the brightness. HVAC control: Devices for heating, ventilation, air conditioning (HVAC) are switched from energy-saving mode to comfort mode dependent on movement. Operating modes: Single detector, Master, Slave, Master in parallel operation. Master: Controls the lighting and HVAC system. Additional detectors as slaves increase the area of detection. Slave: Only detects movement in its area and sends the information to the master. Master in parallel operation: Controls the lighting in its area (can be expanded with additional detectors as slaves). The only master in the installation only controls the HVAC system for the entire area. 2 logic gates

Angle of detection: 360°

Opening angle: 45°

Range: max. 20 x 4 m (tangential)

max. 12 x 4 m (radial)

Mounting height: 2.5 - 5 m

Optimal mounting height: 2.8 m

Time setting: 60 s - 255 min.

Sensors: 2 x passive infrared

Number of zones: 280

Detection brightness: internal light sensor adjustable from approx. 2 to 1000 Lux

Protection rating: IP 20

EC Directives: Low voltage directive 2006/95/EC and EMC directive 2004/108/EC

Dimensions: 124 x 78 mm (Ø x H)

Accessories: Remote control for KNX presence detector MTN6300-0002

Protective basket for KNX presence detector MTN6300-0001

Movement detector



KNX High Bay presence detector



Version	Art. no.	
white	MTN6354-0019	New

KNX presence detector for surface-mounted installation in rooms with high ceilings, e.g. high-bay warehouses or sports halls.

The presence detector detects the presence of persons even in the case of small movements. Control of the lighting is carried out dependent on movement (2 channels) or additionally dependent on brightness (1 channel) via KNX telegrams. If there is sufficient daylight, the lighting is switched off or adapted to a detection brightness (constant light regulation).

Devices for heating, ventilation or air conditioning (HVAC) can also be controlled (1 channel). The presence detector has two detection sensors (passive infrared), a brightness sensor, an IR receiver and an LED to indicate a detected movement, in test mode indication of the activated programming mode.

The presence detector can be used as a single detector or in master-slave mode. The setting is carried out in the ETS.

The presence detector can also be set and tested without the ETS, but with the appropriate remote control (available as an accessory).

Indoor installation on ceiling (IP 54) with surface-mounted housing with two screws and plugs.

Optionally, a protective metal basket (available as an accessory) can be installed to protect the lens.

KNX software functions: Movement detection: The detected presence of a person is signalled using a KNX telegram. Lighting control: The room lighting is controlled depending on movement and brightness. If there is sufficient daylight, the lighting is switched off or dimmed to a constant level. Basic lighting: Activates basic lighting after the overtravel time has elapsed, either for a limited time or dependent on the brightness. HVAC control: Devices for heating, ventilation, air conditioning (HVAC) are switched from energy-saving mode to comfort mode dependent on movement. Operating modes: Single detector, Master, Slave, Master in parallel operation. Master: Controls the lighting and HVAC system. Additional detectors as slaves increase the area of detection. Slave: Only detects movement in its area and sends the information to the master. Master in parallel operation: Controls the lighting in its area (can be expanded with additional detectors as slaves). The only master in the installation only controls the HVAC system for the entire area. 2 logic gates

Angle of detection: 360°

Opening angle: 180°

Range: Radius of max. 18 m (tangential)

Mounting height: 4 - 14 m

Optimal mounting height: 12 m

Time setting: 60 s - 255 min.

Sensors: 2 x passive infrared

Number of zones: 1416

Detection brightness: internal light sensor adjustable from approx. 2 to 1000 Lux

Protection rating: IP 54

EC Directives: Low voltage directive 2006/95/EC and EMC directive 2004/108/EC

Dimensions: 124 x 65 mm (Ø x H)

Accessories: Remote control for KNX presence detector MTN6300-0002

Protective basket for KNX presence detector MTN6300-0001

Movement detector



KNX Corridor presence detector



Version	Art. no.
white	MTN6355-0019 New

KNX presence detector for surface-mounted installation in long corridors. The presence detector detects the presence of persons even in the case of small movements. Control of the lighting is carried out dependent on movement (2 channels) or additionally dependent on brightness (1 channel) via KNX telegrams. If there is sufficient daylight, the lighting is switched off or adapted to a detection brightness (constant light regulation). Devices for heating, ventilation or air conditioning (HVAC) can also be controlled (1 channel). The presence detector has two detection sensors (passive infrared), a brightness sensor, an IR receiver and an LED to indicate a detected movement, in test mode indication of the activated programming mode. The presence detector can be used as a single detector or in master-slave mode. The setting is carried out in the ETS. The presence detector can also be set and tested without the ETS, but with the appropriate remote control (available as an accessory). Indoor installation on ceiling (IP 54) with surface-mounted housing with two screws and plugs.

Optionally, a protective metal basket (available as an accessory) can be installed to protect the lens.

KNX software functions: Movement detection: The detected presence of a person is signalled using a KNX telegram. Lighting control: The room lighting is controlled depending on movement and brightness. If there is sufficient daylight, the lighting is switched off or dimmed to a constant level. Basic lighting: Activates basic lighting after the overtravel time has elapsed, either for a limited time or dependent on the brightness. HVAC control: Devices for heating, ventilation, air conditioning (HVAC) are switched from energy-saving mode to comfort mode dependent on movement. Operating modes: Single detector, Master, Slave, Master in parallel operation. Master: Controls the lighting and HVAC system. Additional detectors as slaves increase the area of detection. Slave: Only detects movement in its area and sends the information to the master. Master in parallel operation: Controls the lighting in its area (can be expanded with additional detectors as slaves). The only master in the installation only controls the HVAC system for the entire area. 2 logic gates

Angle of detection: 360°

Opening angle: 45°

Range: max. 20 x 4 m (tangential)

max. 12 x 4 m (radial)

Mounting height: 2.5 - 5 m

Optimal mounting height: 2.8 m

Time setting: 60 s - 255 min.

Sensors: 2 x passive infrared

Number of zones: 280

Detection brightness: internal light sensor adjustable from approx. 2 to 1000 Lux

Protection rating: IP 54

EC Directives: Low voltage directive 2006/95/EC and EMC directive 2004/108/EC

Dimensions: 124 x 65 mm (Ø x H)

Accessories: Remote control for KNX presence detector MTN6300-0002

Protective basket for KNX presence detector MTN6300-0001

Movement detector



KNX Mini presence detector



Version	Art. no.
white	MTN6303-0019 New

KNX presence detector for inconspicuous installation in suspended ceilings. The presence detector detects the presence of persons even in the case of small movements. Control of the lighting is carried out dependent on movement (4 channels) or additionally dependent on brightness (1 channel) via KNX telegrams. If there is sufficient daylight, the lighting is switched off or adapted to a detection brightness (constant light regulation). Devices for heating, ventilation or air conditioning (HVAC) can also be controlled (1 channel). The presence detector has four detection sensors (passive infrared), a brightness sensor, an IR receiver and an LED to indicate a detected movement, in test mode indication of the activated programming mode.

The presence detector can be used as a single detector or in master-slave mode. The setting is carried out in the ETS.

The presence detector can also be set and tested without the ETS, but with the appropriate remote control (available as an accessory).

Indoor installation in suspended ceilings The detector is installed with a retainer spring in a circular aperture (diameter 35 mm) in a suspended ceiling (e.g. plasterboard). The minimum installation depth is 65 mm.

KNX software functions: Movement detection: The detected presence of a person is signalled using a KNX telegram. Lighting control: The room lighting is controlled depending on movement and brightness. If there is sufficient daylight, the lighting is switched off or dimmed to a constant level. Basic lighting: Activates basic lighting after the overtravel time has elapsed, either for a limited time or dependent on the brightness. HVAC control: Devices for heating, ventilation, air conditioning (HVAC) are switched from energy-saving mode to comfort mode dependent on movement. Operating modes: Single detector, Master, Slave, Master in parallel operation. Master: Controls the lighting and HVAC system. Additional detectors as slaves increase the area of detection. Slave: Only detects movement in its area and sends the information to the master. Master in parallel operation: Controls the lighting in its area (can be expanded with additional detectors as slaves). The only master in the installation only controls the HVAC system for the entire area. 2 logic gates

Angle of detection: 360°
Range: max. 6 x 6 m (tangential)
 max. 4 x 4 m (radial)
Mounting height: 2 - 5 m
Optimal mounting height: 2.8 m
Time setting: 60 s - 255 min.
Sensors: 4 x passive infrared
Detection brightness: internal light sensor adjustable from approx. 2 to 1000 Lux
IP protection rating: IP 20
EC guidelines: Low voltage directive 2006/95/EC and EMC directive 2004/108/EC
Dimensions: 43 x 71 mm (Ø x H)
Accessories: Remote control for KNX presence detector MTN6300-0002

Movement detector



Remote control for KNX presence detector



Version	Art. no.
	MTN6300-0002 New

IR remote control for operating and setting KNX presence detectors.
 The IR remote control can be used to carry out the following functions and settings:

- Activation of KNX programming mode
- Selecting test modes
- Starting and ending test mode
- Calibrating brightness measurement
- Setting the brightness value
- Setting the lighting overtravel time
- Setting switch-on delay for HVAC
- Setting the basic lighting duration

To be completed with: KNX High Bay presence detector FM
 KNX Präsenz Halle AP MTN6354-0019
 KNX Corridor presence detector FM MTN6305-0019
 KNX Präsenz Korridor AP MTN6355-0019
 KNX Mini presence detector
 MTN6303-0019

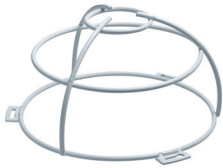

Protective basket for KNX presence detector





Version	Art. no.
	MTN6300-0001 New

Protective grille for movement and presence detectors.
 Surface-mounted installation with screws
To be completed with: KNX High Bay presence detector FM
 KNX Präsenz Halle AP MTN6354-0019
 KNX Corridor presence detector FM MTN6305-0019
 KNX Präsenz Korridor AP MTN6355-0019

Movement detector



KNX ARGUS Presence Basic		KNX ARGUS Presence	
			
Version	Art. no.	Version	Art. no.
polar white	MTN630719	aluminium	MTN630860
aluminium	MTN630760	polar white	MTN630819
<p>Presence detection indoors. If KNX ARGUS Presence detects smaller movements in the room, data telegrams are transmitted via KNX to control the lighting, blind or heating at the same time. When the lighting is controlled by brightness-dependent movement detection, the device constantly monitors the brightness in the room. If sufficient natural light is at hand, the device switches the artificial light off even if a person is present. The overshoot time can be adjusted using the ETS. With integrated bus coupling unit. For ceiling mounting in a size 60 mounting box, optimal installation at 2.5 m. Can also be mounted to ceilings using the surface mounting housing for ARGUS Presence. KNX software functions: Two movement/presence blocks: up to four functions can be triggered per block. Telegrams: 1 bit, 1 byte, 2 bytes. Normal operation (no master/slave), safety pause, disable function. Self-adjusting staircase timer. Actual brightness value: can be specified via the internal and/or an external light sensor. Angle of detection: 360° Range: a radius of max. 7 m (at a mounting height of 2.50 m) Number of levels: 6 Number of zones: 136 with 544 switching segments Number of movement sensors: 4 Light sensor: internal light sensor infinitely adjustable from approx. 10 to 2000 Lux (ETS); external light sensor via KNX EC Directives: Low-voltage guideline 2006/95/EC and EMC guideline 2004/108/EC Accessories: Surface-mounted housing for ARGUS Presence MTN550619 Contents: With bus connecting terminal and supporting plate.</p>		<p>Presence detection indoors. If KNX ARGUS Presence detects smaller movements in the room, data telegrams are transmitted via KNX to control the lighting, blind or heating at the same time. When the lighting is controlled by brightness-dependent movement detection, the device constantly monitors the brightness in the room. If sufficient natural light is at hand, the device switches the artificial light off even if a person is present. The overshoot time can be adjusted using the ETS. With integrated bus coupling unit. For ceiling mounting in a size 60 mounting box, optimal installation at 2.5 m. Can also be mounted to ceilings using the surface mounting housing for ARGUS Presence. KNX software functions: Five movement/presence blocks: up to four functions can be triggered per block. Telegrams: 1 bit, 1 byte, 2 bytes. Normal operation, master, slave, monitoring, safety pause, disable function. Four movement sensors: the sensitivity and range can be set separately for each sensor. Self-adjusting staircase timer. Actual brightness value: can be detected via the internal and/or an external light sensor. Actual value correction. Angle of detection: 360° Range: a radius of max. 7 m (at a mounting height of 2.50 m) Number of levels: 6 Number of zones: 136 with 544 switching segments Number of movement sensors: 4, separately adjustable Light sensor: internal light sensor infinitely adjustable from approx. 10 to 2000 Lux (ETS); external light sensor via KNX EC Directives: Low-voltage guideline 2006/95/EC and EMC guideline 2004/108/EC Accessories: Surface-mounted housing for ARGUS Presence MTN550619 Contents: With bus connecting terminal and supporting plate.</p>	

Movement detector



KNX ARGUS Presence with light control and IR receiver



Version	Art. no.
polar white	MTN630919
aluminium	MTN630960

Presence detection indoors.

If KNX ARGUS Presence detects smaller movements in the room, data telegrams are transmitted via KNX to control the lighting, blind or heating at the same time.

When the lighting is controlled by brightness-dependent movement detection, the device constantly monitors the brightness in the room. If sufficient natural light is at hand, the device switches the artificial light off even if a person is present. The overshoot time can be adjusted using the ETS.

Light control enables the required brightness in a room to be achieved permanently. Dimming and the optional use of a second lighting group maintains a constant brightness.

Individual ARGUS Presence configurations can be changed or other KNX devices can be controlled remotely using the IR receiver.

With integrated bus coupling unit. For ceiling mounting in a size 60 mounting box, optimal installation at 2.5 m. Can also be mounted to ceilings using the surface mounting housing for ARGUS Presence.

KNX software functions: Five movement/presence blocks: up to four functions can be triggered per block. Telegrams: 1 bit, 1 byte, 2 bytes.

An additional light control block: brightness can be maintained constant by dimming and an additional adjustable level.

IR receiver function. IR configuration: setting the brightness threshold, staircase timer factors or range.

Normal operation, master, slave, monitoring, safety pause, disable function. Four movement sensors: the sensitivity and range can be set separately for each sensor. Self-adjusting staircase timer. Actual brightness value: can be detected via the internal and/or an external light sensor. Actual value correction.

Angle of detection: 360°

Range: a radius of max. 7 m (at a mounting height of 2.50 m)

Number of levels: 6

Number of zones: 136 with 544 switching segments

Number of movement sensors: 4, separately adjustable

Light sensor: internal light sensor infinitely adjustable from approx. 10 to 2000 Lux (ETS); external light sensor via KNX

Number of IR channels: 10 for controlling KNX devices, 10 for configuration

EC Directives: Low-voltage guideline 2006/95/EC and EMC guideline 2004/108/EC

Accessories: Surface-mounted housing for ARGUS Presence MTN550619

Transmitter: IR universal remote control MTN5761-0000

Contents: With bus connecting terminal and supporting plate.



Surface-mounted housing for ARGUS Presence



Version	Art. no.
polar white	MTN550619

The surface-mounted housing for ARGUS Presence devices also allows them to be surface mounted.

- for surface-mounting of the LON Multi-Sensor LA-21 (art. no. 42320-104) and ILA-22 (art. no. 42320-105)

- colour: polar white (similar to RAL 9010)

To be completed with: ARGUS Presence MTN550590, ARGUS Presence with IR receiver and for extension unit operation MTN550591, KNX ARGUS Presence Basic MTN6307.., KNX ARGUS Presence MTN6308.., KNX ARGUS Presence with light control and IR receiver MTN6309..

Movement detector



KNX ARGUS Presence 180/2.20 m flush-mounted



Version	Art. no.
<input checked="" type="checkbox"/> white, glossy	MTN630444
<input type="checkbox"/> polar white, glossy	MTN630419
<input type="checkbox"/> active white, glossy	MTN630425
<input checked="" type="checkbox"/> anthracite	MTN630614
<input type="checkbox"/> aluminium	MTN630660

For System M.

Presence detection indoors.

If KNX ARGUS Presence detects smaller movements in the room, data telegrams are transmitted via KNX to control the lighting, blind or heating at the same time.

When the lighting is controlled by brightness-dependent movement detection, the device constantly monitors the brightness in the room. If sufficient natural light is at hand, the device switches the artificial light off even if a person is present. The overshoot time can be adjusted using the ETS.

With integrated bus coupling unit. For wall mounting in a size 60 mounting box, optimal installation at 2.2 m. With anti-crawl protection.

KNX software functions: Five movement/presence blocks: up to four functions can be triggered per block. Telegrams: 1 bit, 1 byte, 2 bytes.

Normal operation, master, slave, monitoring, safety pause, disable function. Two movement sensors: the sensitivity and range can be set separately for each sensor. Self-adjusting staircase timer. Actual brightness value: can be detected via the internal and/or an external light sensor. Actual value correction.

Angle of detection: 180°

Range: 8 m right/left, 12 m to the front (for a mounting height of 2.20 m)

Mounting height: 2.2 m or 1.1 m at half the range

Time: adjustable in steps from 1 s to 8 min (potentiometer) or adjustable from 1 s to 255 hours (ETS)

Number of levels: 6

Number of zones: 46

Number of movement sensors: 2, separately adjustable

Light sensor: internal light sensor infinitely adjustable from approx. 10 to 2000 Lux (ETS); external light sensor via KNX

EC Directives: Low-voltage guideline 2006/95/EC and EMC guideline 2004/108/EC

Contents: With bus connecting terminal and supporting plate.

With cover segments to limit the area of detection.

Other sensors



KNX brightness and temperature sensor



Version	Art. no.
light grey	MTN663991

The sensor records brightness and temperature and transmits these values to the bus. It has a temperature sensor and a brightness sensor.

- 3 universal channels for single tasks or logic operations. Temperature and brightness threshold in any combination.
- Sun protection channel for blinds/roller shutter control. Objects for: twilight threshold, brightness threshold, drive control, automatic sun function, teaching, security.
- Automatic sun protection. Controls the blinds automatically during the day.
- Teaching object. With this, every brightness threshold can be reset by the touch of a key. Suitable for mounting on an outside wall.

With integrated bus coupler. The bus is connected using a bus connecting terminal.

Power consumption: max. 150 mW

Sensors: 2

Temperature measurement range: - 25 °C to + 55 °C (±5 % or ±1 degree)

Brightness measurement range: 1 to 100,000 lux (±20% or ±5 lux)

Type of protection: IP 54 according to DIN EN 60529 for vertical installation with cover

Dimensions: 110 x 72 x 54 mm



KNX CO₂, humidity and temperature sensor AP



Version	Art. no.
polar white	MTN6005-0001

The device is a combined sensor for CO₂, temperature and humidity measurement (relative humidity).

It is used to monitor the air quality in meeting rooms, offices, schools/kindergartens, passive or low-energy houses and living areas without controlled ventilation.

The CO₂ content of the air is a verifiable indicator of the ambient air quality. The higher the CO₂ content, the worse the ambient air is.

KNX software functions: Threshold adjustment range: 500–2550 ppm. Object ""Physical value"": 0-9999 ppm. There are 3 independent measured value thresholds for CO₂ and relative humidity and a threshold for the temperature value. An action is carried out if the thresholds are not reached or if they are exceeded: Send priority. Switching, value. Each threshold has a locking object.

Power supply: bus voltage

Current consumption from bus: max. 10 mA

Ambient temperature: -5 °C ... +45 °C

Measuring range, CO₂: 300 – 9999 ppm

Measuring range, temperature: 0 °C ... +40 °C

Measuring range, humidity: linear 20 % ... 100 %

Type of protection: IP 20 in accordance with DIN EN 60529

Dimensions: 74x74x31 mm

Other sensors



KNX weather station Basic V2



Version	Art. no.
---------	----------

MTN6904-0001

The KNX weather station Basic V2 records weather data, analyses these and can transmit them to the bus. The device has a wind sensor, precipitation sensor, temperature sensor and 3 brightness sensors.

- Self contained outdoor weather station
- For measuring wind, rain, brightness and temperature
- For fully automatic blinds and sun protection control with automatic adjustment of blinds according to position of the sun
- Rain sensor with integrated heating
- The weather station can also be operated without mains supply. The heating of the rain sensor will not function then
- Measurement and evaluation directly on device
- Sun protection for up to three facades via 3 integrated brightness sensors
- 8 sun protection channels
- 4 additional threshold channels for connection of external KNX sensors
- 6 logic channels
- Display of weather data on visualisation

Suitable for mounting on an outside wall or with optional accessories on a corner or on a mast. With integrated bus coupler. The bus is connected using a bus connecting terminal. An additional AC 230 V power supply is required for the heating unit.

KNX software functions:

- Adjustment of slat position according to current position of the sun.
- Sun protection area both horizontal (azimuth) and vertical (elevation) can be set exactly.
- 3 installed brightness sensors at 90° spacing.
- 2 objects for external brightness sensors.
- Shading can be temporarily interrupted via object.
- Universal channels with AND/OR linking of weather parameters.
- Threshold channels with delay with falling below and exceeding.
- Logic channels with 4 input objects + internal link that can be configured with status of the universal and threshold channels.

Power supply: AC 110-230 V, 50-60 Hz

Power consumption: max. 10 mA with bus voltage

Stand-by consumption: < 0.5 W

Measuring range:

Brightness: 1 - 100000 lx

Temperature: - 30 °C ... + 60 °C

Wind speed: 2 - 30 m/s

Ambient temperature: - 20 °C ... + 55 °C

Protection class: II

Type of protection: IP 44

Dimensions: 227x121x108 mm (LxWxH)

Accessories: Mast and corner fastening for KNX weather station Basic V2 MTN6904-0002



Mast and corner fastening for KNX weather station Basic V2



Version	Art. no.
---------	----------

MTN6904-0002

- For corner installation of max. 2 KNX weather stations Basic V2.
- For mast installation of 1 KNX weather station Basic V2.
- Diameter 48–60 mm.

To be completed with: KNX weather station Basic V2 MTN6904-0001

Other sensors



Weather station REG-K/4-gang



Version	Art. no.
light grey	MTN682991

The weather station records and processes analogue sensor signals such as wind speed, brightness, twilight, precipitation and a DCF-77 signal. Up to four analogue sensors and the DCF-77 weather combi-sensor can be connected in any combination.

In connection with the 4-gang analogue input module, 8 analogue inputs are available, to which the connection is made using the sub-bus.

If DCF-77 weather combi-sensors are used, it is possible to access a pre-configured setting in the software.

The measured values are converted by the weather station into 1 byte / 2 byte telegrams (EIS 6/5 value). This enables bus devices (visualisation software, measured value displays) to access the control processes, generate signals or control weather-dependent processes. Programming is performed using the ETS tool for the weather station.

- Two limit values per sensor (not for rain)
- Connection of multiple wind sensors
- 14 signals can be evaluated
- Evaluation of DCF-77 time signal (date and time)
- Astro function
- Logic operation controller for application of limit-value-dependent actions (even external)
- Shading of individual façade segments
- Signal monitoring of the combi-sensors with object for the following protective measures
- Checking the wind signal for conclusiveness with object for the following protective measures
- Selective façade shading (for 4 façades) with adjustment of the basic brightness, façade alignment, angle of opening relative to the sun.
- External objects for intervention in basic brightness, angle of opening and limit values
- Alarm byte
- Continuity monitoring with report on the bus

For installation on DIN rails TH35 according to EN 60715. The bus is connected using a bus connecting terminal; a data rail is not necessary.

Auxiliary voltage: AC 24 V (+/-10 %)

Analogue inputs: 4

Current interface: 0 ... 20 mA, 4 ... 20 mA

Voltage interface: 0 ... 1 V, 0 ... 10 V

Outputs: DC 24 V, 100 mA

Device width: 4 modules = approx. 72 mm

In KNX, to be completed with: Power supply REG, AC 24 V/1 A MTN663529

Accessories: Weather combi-sensor DCF-77 MTN663692, Wind sensor with 0-10 V interface MTN663591, Wind sensor with 0-10 V interface and heating MTN663592, Rain sensor MTN663595, Brightness sensor MTN663593, Twilight sensor MTN663594, Temperature sensor MTN663596

Contents: With bus connecting terminal and cable cover.

Other sensors



Weather combi-sensor DCF-77



Version	Art. no.
black	MTN663692

The weather combi-sensor includes a wind sensor, precipitation sensor, twilight sensor and three brightness sensors (East, South, West). With integral DCF77 receiver, antenna rotatable through 45° and integrated heater (protection against thawing and condensation). Suitable for external installation on a wall or a pole. The sensor is connected to an REG-K 4-gang weather station.

The weather data is evaluated in the weather station. The necessary power supplies are provided by the weather station with connected power supply REG.

Power supply: AC 24 V (+/- 15 %)

Power consumption: max. 600 mA (with heating)

Sensors: 6

Wind speed: 1 ... 40 m/s (≤ 0.5 m/s)

Brightness: 0 ... 110 klux (+/- 10 %)

Twilight: 0 ... 250 lux

Type of protection: IP 65 when installed

Temperature range: - 40 °C ... + 60 °C (non-icing)

Fixing method: Mounting bracket

Dimensions: 130x200 mm (ØxH)

In KNX, to be completed with: Weather station REG-K/4-gang MTN682991



Wind sensor with 0-10 V interface



Version	Art. no.
polar white	MTN663591

The wind sensor evaluates the wind speed and converts it into an analogue 0-10 V output voltage. For external installation and connection to the weather station REG-K/4-gang or the analogue input REG-K/4-gang. These two devices provide the supply voltage necessary to operate the sensor.

Measuring range: 0.7 ... 40 m/s, linear

Output: 0 ... 10 V

External power supply:

Voltage: 24 V DC (18-32 V DC)

Power consumption: approx. 12 mA

General specifications:

Type of protection: IP 65

Load: max. 60 m/s transient

Incoming cable: 3 m, LiYY 6 x 0.25 mm²

Fixing method: Mounting bracket

Mounting position: vertical

In KNX, to be completed with: Weather station REG-K/4-gang MTN682991, Analogue input REG-K 4-gang MTN682191.

Contents: With mounting bracket.

Wind sensor with 0-10 V interface and heating



Version	Art. no.
polar white	MTN663592

The wind sensor evaluates the wind speed and converts it into an analogue 0-10 V output voltage. The integrated heater can be operated via an external power supply of AC 24 V/500 mA for trouble-free operation in frosty weather.

For external installation and connection to the weather station REG-K/4-gang or the analogue input REG-K/4-gang. These two devices provide the supply voltage necessary to operate the sensor.

Measuring range: 0.7 ... 40 m/s, linear

Output: 0 ... 10 V

External power supply:

Voltage: 24 V DC (18-32 V DC)

Power consumption: approx. 12 mA

Heating: 24 V DC/AC PTC element (80° C)

General specifications:

Type of protection: IP 65

Load: max. 60 m/s transient

Incoming cable: 3 m, LiYY 6 x 0.25 mm²

Fixing method: Mounting bracket

Mounting position: vertical





In KNX, to be completed with: Weather station REG-K/4-gang MTN682991, Analogue input REG-K 4-gang MTN682191.

Accessories: Power supply REG, AC 24 V/1 A MTN663529

Contents: With mounting bracket.

Other sensors



Rain sensor		Temperature sensor	
			
Version	Art. no.	Version	Art. no.
	MTN663595	light grey	MTN663596

The rain sensor is used to record and evaluate precipitation and is intended for external mounting. A sensor evaluates the conductivity of the rainwater. The heating is controlled by a microprocessor which supplies an output signal of 0 V or 10 V. The end of the rainfall can be recorded almost immediately with the help of an in-built heater. The heater requires an additional voltage of 24 V AC or DC. For external installation and connection to the weather station REG-K/4-gang or the analogue input REG-K/4-gang. These two devices provide the supply voltage necessary to operate the sensor.

Output: 0 V dry, 10 V rain
External power supply:
Voltage: 24 V DC (15-30 V DC)
Power consumption: approx. 10 mA (without heating)
Heating: 24 V DC/AC max. 4.5 W
General specifications:
Type of protection: IP 65
Incoming cable: 3 m, UYY 5 x 0.25 mm²
Fixing method: Mounting bracket
Mounting position: approx. 45°
In KNX, to be completed with: Weather station REG-K/4-gang MTN682991, Analogue input REG-K 4-gang MTN682191.
Accessories: Power supply REG, AC 24 V/1 A MTN663529
Contents: With holder for installing the sensor on walls and masts.

The temperature is measured with the temperature sensor and converted into an analogue output signal of 0-10 V. For external installation and connection to the weather station REG-K/4-gang or the analogue input REG-K/4-gang. These two devices provide the supply voltage necessary to operate the sensor.

Measuring range: -30° C to +70° C linear
Output: 0 ... 10 V short-circuit-proof
External power supply:
Voltage: 24 V DC (15-30 V DC)
Power consumption: approx. 3 mA
General specifications:
Incoming cable: using PG7 screw fitting
Recommended cable: 3 x 0.25 mm²
Type of protection: IP 65
Dimensions: 58 x 35 x 64 (W x H x D)
In KNX, to be completed with: Weather station REG-K/4-gang MTN682991, Analogue input REG-K 4-gang MTN682191.

Other sensors



Brightness sensor		Twilight sensor	
-------------------	--	-----------------	--



Version	Art. no.	Version	Art. no.
light grey	MTN663593	light grey	MTN663594

The brightness sensor is required for recording and evaluating brightness. Brightness is recorded via a photoelectric diode and electronically converted into an analogue output signal of 0 V - 10 V.

For external installation and connection to the weather station REG-K/4-gang or the analogue input REG-K/4-gang. These two devices provide the supply voltage necessary to operate the sensor.

Measuring range: 0 to 60,000 lux, linear
Output: 0 ... 10 V short-circuit-proof

External power supply:
Voltage: 24 V DC (15-30 V DC)
Power consumption: approx. 5 mA

General specifications:
Incoming cable: using PG7 screw fitting
Recommended cable: 3 x 0.25 mm²
Type of protection: IP 65

Dimensions: 58 x 35 x 64 (W x H x D)
In KNX, to be completed with: Weather station REG-K/4-gang MTN682991, Analogue input REG-K 4-gang MTN682191.

The twilight sensor is required to record and evaluate brightness. Brightness is recorded via a photoelectric diode and electronically converted into an analogue output signal of 0 V - 10 V.

For external installation and connection to the weather station REG-K/4-gang or the analogue input REG-K/4-gang. These two devices provide the supply voltage necessary to operate the sensor.

Measuring range: 0 to 255 lux, linear
Output: 0 ... 10 V short-circuit-proof

External power supply:
Voltage: 24 V DC (15-30 V DC)
Power consumption: approx. 5 mA

General specifications:
Incoming cable: using PG7 screw fitting
Recommended cable: 3 x 0.25 mm²
Type of protection: IP 65

Dimensions: 58 x 35 x 64 (W x H x D)
In KNX, to be completed with: Weather station REG-K/4-gang MTN682991, Analogue input REG-K 4-gang MTN682191.



Analogue input REG-K 4-gang



Version	Art. no.
light grey	MTN682191

The analogue input records and processes analogue sensor signals. Up to four analogue sensors can be connected in any combination. In connection with the analogue input module REG/4-gang, 8 analogue inputs are available, to which the connection is made using the sub-bus.

Evaluation and limit value processing is performed in the analogue input. With continuity checking of the 4 ... 20 mA inputs.

For installation on DIN rails TH35 according to EN 60715. The bus is connected using a bus connecting terminal; a data rail is not necessary.

Auxiliary voltage: AC 24 V (+/-10 %)
Analogue inputs: 4

Current interface: 0 ... 20 mA, 4 ... 20 mA
Voltage interface: 0 ... 1 V, 0 ... 10 V
Outputs: DC 24 V, 100 mA

Continuity checking: 4 ... 20 mA
Device width: 4 modules = approx. 72 mm

In KNX, to be completed with: Power supply REG, AC 24 V/1 A MTN663529
Accessories: Wind sensor with 0-10 V interface MTN663591, Wind sensor with 0-10 V interface and heating MTN663592, Rain sensor MTN663595, Brightness sensor MTN663593, Twilight sensor MTN663594, Temperature sensor MTN663596
Contents: With bus connecting terminal and cable cover.

Time switch

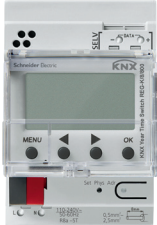

KNX Year Time Switch REG-K/8/800



Version	Art. no.
	MTN6606-0008

8-channel KNX time switch with year and astro program. Time switch with connection option for DCF and GPS antenna. To enable radio-controlled time synchronisation via DCF or GPS, the device needs to be fitted with the relevant antenna. Time and date can be issued on the bus.

The device can be programmed manually on the device itself or on the PC using software. After programming on the PC, all switching times are exported to a memory chip available as an accessory, and transmitted from this into one or more time switches.

- Comprehensive annual clock functions
- 8 channels
- 800 memory switching time locations
- 8 years power reserve (lithium battery)
- Text-oriented user interface in the display
- Display lighting (can be switched off)
- Astronomic switch function (automatic calculation of sunrise and sunset times for the whole year)
- Time synchronisation by connecting an external DCF or GPS antenna; in the case of GPS, additional positioning for astro program
- Time and date synchronisation for other bus devices
- Automatic changeover between summer and winter time
- Switch-off timer
- Holiday program
- 2 random programs
- Integrated operating hours counter
- ON/OFF switching times
- Impulse program
- Cycle program
- Switch preselection
- ON/OFF permanent switching
- PIN coding
- Interface for memory card (PC programming)
- Screwless terminals for 2 lines each

With integrated bus coupler. For installation on DIN rails TH35 according to EN 60715. The bus is connected using a bus connecting terminal; a data rail is not necessary.

Operating voltage: Bus: DC 24 V

Mains: AC 110-240 V

Shortest switching time: 1 s

Accuracy: $\leq \pm 0.5s/day$

Power reserve: 8 years

Type of protection: IP 20

Device width: 3 modules = approx. 54 mm

In KNX, to be completed with: DCF77 Antenna V2 MTN6606-0070, GPS Antenna MTN6606-0071

Accessories: IHP+ programming kit for PC CCT15860, IHP+ key CCT15861

GPS Antenna



Version	Art. no.
	MTN6606-0071

Antenna for receiving the time by GPS radio signal. Connect the antenna to the year time switch.

Worldwide time synchronisation and positioning via GPS satellite signal reception. The antenna is connected using a 2-core cable (max. 100 m).

In KNX, to be completed with: KNX Year Time Switch REG-K/8/800 MTN6606-0008



Other sensors



DCF77 Antenna V2



Version	Art. no.
---------	----------

MTN6606-0070

Antenna for receiving the time by radio signal. Connect the antenna to the year time switch. To get the best reception, the antenna should not be installed in the cellar or the distribution system. It is connected via a separate 2-core, unshielded power line (max. 100 m), to which up to 5 year time switches can be connected. Incorrect polarity, short circuits and breaks in the antenna cable are each displayed visually.

Type of protection: IP 54

In KNX, to be completed with: KNX Year Time Switch REG-K/8/800 MTN6606-0008



IHP+ key



Version	Art. no.
---------	----------

CCT15861

Memory card for saving and duplicating programs for time switches. The program created by the software is loaded to the memory chip and can then be imported to one or more time switches.

For IHP+ 1c/2c, ICAstro 1c/2c, IC100kp+ 1c/2c, IHP 1c 18 mm, IHP+ 1c 18 mm

In KNX, to be completed with: KNX Year Time Switch REG-K/8/800 MTN6606-0008



IHP+ programming kit for PC



Version	Art. no.
---------	----------

CCT15860

For IC Astro and IC 100kp+.

In KNX, to be completed with: KNX Year Time Switch REG-K/8/800 MTN6606-0008

Accessories: IHP+ key CCT15861

Contents: With adapter, memory chip, CD-ROM and 2 m USB cabel.

Other sensors



KNX timer REG-K



Version	Art. no.
light grey	MTN677290

The timer sends time and date to the bus and can be operated with or without a DCF77 antenna.

- Automatic changeover between summer and winter time (can be switched off)
- Own adjustable changeover rule
- The data can be sent periodically or on request
- Lithium cell: time stays the same in the event of loss of bus power

For installation on DIN rails TH35 according to EN 60715. The bus is connected using a bus connecting terminal; a data rail is not necessary.

Accuracy: 1 s/day, the application allows additional adjustment

Reserve power: 10 years

Antenna line length: max. 100 m

Type of protection: IP 20

EC directives: Low-voltage guideline 2006/95/EC and EMC directive 2004/108/EC

Device width: 2 modules = approx. 36 mm

Accessories: DCF77 antenna MTN668091



DCF77 antenna



Version	Art. no.
light grey	MTN668091



Antenna for receiving the time by radio signal. The antenna should be connected to a year time switch REG-K/4/324 DCF-77.

Type of protection: IP 54

In KNX, to be completed with: KNX timer REG-K MTN677290



Contents: With mounting bracket.



Other sensors

	Blind/switch actuator REG-K/ x/x/10 with manual mode		Switch actuator REG-K/8x230/6	Switch actuator REG-K/x230/10 with manual mode			
Article number	 MTN649908 MTN649912		 MTN646808	 MTN649202 MTN649204 MTN649208 MTN649212			
Number of switch contacts	16	24	8	2	4	8	12
Device width	8 TE	12 TE	4 modules	2.5 modules	4 modules	4 modules	6 modules
Manual mode ■ Mechanical ■ Electrical ■ Reset by manual mode triggered actions	— ■ (lockable) —		— — —	— ■ (lockable) —			
Connecting terminal (consumer load)	Plug-in screw terminals		Plug-in screw terminals	Plug-in screw terminals			
Nominal voltage, AC, 50-60 Hz	AC 100-240 V		AC 230 V	AC 230 V			
Nominal current	10 A, $\cos\varphi = 0,6$		6 A, $\cos\varphi = 0.6$	10 A, $\cos\varphi = 1 / 10 A, \cos\varphi = 0.6$			
Connection power max. at AC 230 V ■ Incandescent lamps ■ Halogen lamps ■ Capacitive load ■ Fluorescent lamps	2000 W 1700 W 105 μ F 1800 W uncompensated, 1000 W parallel-compensated		1380 W 1380 W 105 μ F 1000 VA	2000 W 1700 W 105 μ F 1800 W uncompensated, 1000 W parallel-compensated			
DC power supply	not allowed		not allowed	not allowed			
Software							
ON/OFF delay	■		■	■			
Staircase lighting function with/without manual OFF ■ Retriggerable ■ Fix (for all push-buttons the same time) ■ Variable (for all push-buttons different times) ■ Retriggerable and adding ■ Retrigger to the higher time ■ Prewarn	■ ■ — — — ■		■ ■ — — — ■	■ ■ — — — ■			
Flashing	—		■	—			
Make/Break contact adjustable	■		■	■			
Changeover contact adjustable	—		■	—			
Status/Status feedback ■ Active ■ Passive ■ Manual mode: Identify and acknowledge / Reset ■ Delayed per device / Delayed per channel	■ ■ ■ / — — / ■		■ ■ — / — — / —	■ ■ ■ / — — / —			
Behaviour of bus voltage failure / bus voltage recovery	■ / ■		■ / ■	■ / ■			
Scenes ■ Sending delay	5 —		8 —	5 —			
Higher priority functions	■ Disable function ■ Logic function or priority function		■ Disable function ■ Logic function or priority function	■ Disable function ■ Logic function or priority function			
Disable function ■ Behaviour of locking after bus voltage recovery	■		■	■			
Logic function ■ Logic operation ■ Value comparison / logic / gate function / filter / time delay	■ — / — / — / — / —		■ — / — / — / — / —	■ — / — / — / — / —			
Central function ■ Time delay / Save changes	■ — / —		■ — / —	■ — / —			
Safety function	—		—	—			
Line monitoring (sending live signal)	—		—	—			

KNX



Functions overview switch actuators

Switch actuator Basic REG-K/x/16 A with manual mode				Switch actuator REG-K/x230/16 with manual mode				Switch actuator REG-K/x230/16 with manual mode and current detection			
											
MTN6700-0002	MTN6700-0004	MTN6700-0008	MTN6700-0012	MTN647393	MTN647593	MTN647893	MTN648493	MTN647395	MTN647595	MTN647895	MTN648495
2	4	8	12	2	4	8	12	2	4	8	12
2.5 modules	4 modules	8 modules	12 modules	2.5 modules	4 modules	8 modules	12 modules	2.5 modules	4 modules	8 modules	12 modules
■ — —				■ — —				■ — ■			
Screw terminals				Screw terminals				Screw terminals			
AC 100-240 V				AC 100-240 V	AC 230 V	AC 100-240 V	AC 230 V	AC 100-240 V	AC 230 V	AC 100-240 V	AC 100-240 V
16 A, cosφ = 0.6				16 A, cosφ = 0.6				16 A, cosφ = 0.6			
3600 W 2500 W 105 μF 2000 VA				3600 W 2500 W 200 μF 2500 VA				3600 W 2500 W 200 μF 2500 VA			
not allowed				not allowed				Purely resistive loads allowed, DC 12-24 V, +10 %, 0,1 - 16 A			
—				■				■			
■ ■ — — — ■				■ ■ — — — ■				■ ■ ■ ■ ■ ■ ■			
—				■				■			
— (make contact)				■				■			
—				■				—			
■ — — / — — / —				■ ■ — / — — / —				■ ■ ■ / ■ ■ / ■			
■ / ■				■ / ■				■ / ■			
— —				8 —				8 ■			
■ Logic function				■ Disable function ■ Logic function or priority function				■ Logic function ■ Disable function or priority function			
— —				■				■			
■ — / — / — / — / —				■ — / — / — / — / —				■ ■ / ■ / ■ / ■ / ■			
■ — / —				■ — / —				■ ■ / ■			
—				—				■			
—				—				■			

	Blind/switch actuator REG-K/ x/x/10 with manual mode		Switch actuator REG-K/8x230/6	Switch actuator REG-K/x230/10 with manual mode			
							
Article number	MTN649908	MTN649912	MTN646808	MTN649202	MTN649204	MTN649208	MTN649212
Current detection							
<ul style="list-style-type: none"> ■ AC/DC ■ Display energy consumption* ■ Several limit monitorings ■ Switch counter ■ Hours counter ■ Combined counter (Switch and hour counter with limit monitoring) 	—	—	—	—	—	—	—
Heating function							
<ul style="list-style-type: none"> ■ Switching ON/OFF (2-point valve) ■ Continuous (PWM) ■ Cyclic surveillance of control value ■ Locking in summer/winter mode ■ Collected response „All valves closed“ ■ Current detection ■ Valve protection cyclical / with telegram ■ Valve protection feedback / status ■ Behaviour when bus voltage fails / when bus voltage returns 	—	—	—	—	—	—	—
	— / —	— / —	— / —	— / —	— / —	— / —	— / —

KNX

Functions overview switch actuators

Switch actuator Basic REG-K/x/16 A with manual mode				Switch actuator REG-K/x230/16 with manual mode				Switch actuator REG-K/x230/16 with manual mode and current detection			
											
MTN6700-0002	MTN6700-0004	MTN6700-0008	MTN6700-0012	MTN647393	MTN647593	MTN647893	MTN648493	MTN647395	MTN647595	MTN647895	MTN648495
— — — — —				— — — — —				■ ■ ■ ■ ■ ■			
— — — — — — — / — — / — — / —				— — — — — — — / — — / — — / —				■ ■ ■ ■ ■ ■ ■ ■ / ■ ■ / ■ ■ / ■			

Switch actuators



Switch actuator, flush-mounted/230/16



Version	Art. no.
polar white	MTN629993

For switching a load via a make contact. With integrated bus coupler and screw terminals. The device is connected to the bus with a bus connecting terminal. The actuator can be built into a 47 mm ceiling socket with hook or a flush-mounted switch box.

KNX software functions: Operation as break or make contact, delay functions for each channel, staircase lighting function with/without manual OFF function, cut-out warning for staircase lighting function, blocking and additional logic operation or priority control, scenes, status feedback function per channel, central function, comprehensive parameterisation for bus voltage failure and recovery, parameterisable download behaviour.

Nominal voltage: AC 100-240 V $\pm 10\%$

Operating voltage: min. AC 90 V - max. AC 265 V

Mains frequency: 50-60 Hz $\pm 10\%$

Nominal current: 16 A, ohmic load $\cos\phi = 1$
10 A, inductive load $\cos\phi = 0,6$

Nominal load

Incandescent lamps: AC 100 V, max. 1173 W

AC 230 V, max. 2700 W

AC 240 V, max. 2817 W

Halogen lamps: AC 100 V, max. 739 W

AC 230 V, max. 1700 W

AC 240 V, max. 1773 W

Fluorescent lamps: AC 100 V, max. 434 VA

AC 230 V, max. 1000 VA

AC 240 V, max. 1043 VA

parallel-compensated

Capacitive load: AC 230 V, 10 A, max. 105 μF

Dimensions: 51x52x29 mm (WxHxD)

Contents: With bus connecting terminal.

Switch actuators



KNX switch actuator 16 A FM with 2 inputs



Version

Art. no.

MTN6003-0001

1-gang switch actuator with two inputs for installation in a size 60 switch box or ceiling socket-outlet with hook. Floating contacts can be connected to the two inputs.

The first input is assigned to the actuator at the factory, enabling operation without programming.

Connection to 230 V via a flexible cable, approx. 20 cm long. The inputs and the KNX are connected via a 6-core, approx. 30 cm long, connecting cable. The connecting cable for the inputs can be extended to a max. of 5 m.

KNX software functions: Switch actuator functions:

Operation as break contact or make contact. Selection of default position on bus voltage failure/recovery. Switch on and/or off delay. Time switch function. Switching. Status feedback. Logic operation. Disable function or priority control. Status feedback object can be inverted.

Input function:

Free assignment of the switching, dimming, blind and valuator functions. Locking object.

Behaviour when bus voltage recovers.

Switching: two switch objects per input. Command on rising/falling edge (ON, OFF, TOGGLE, no reaction).

Dimming: Single surface and dual-surface operation. Time between dimming and switching and dim step values. Telegram repetition and send stop telegram.

Blinds: Command on rising edge (none, UP, DOWN, TOGGLE). Operation concept (Step - Move - Step or Move - Step). Time between short and long operation. Slat adjustment time.

Valuator and lightscene ext. input: Edge (push-button as make contact, push-button as break contact, switch) and value on edge. Value adjustment via long push-button action for valuator. Lightscene ext. unit with memory function.

Nominal voltage: AC 230 V

Nominal current: 16 A, ohmic load

Switch contact: Make contact, floating relay contact

Nominal output

Incandescent lamps: AC 230 V, max. 2500 W

Halogen lamps: AC 230 V, max. 2200 W

LV halogen lamps: max. 1000 VA, wound transformer

max. 1000 W, electronic transformers

Capacitive load: AC 230 V, 10 A, max. 105 µF

Inputs: 2

Temperature range: -5 °C to 45 °C

Type of protection: IP 20

Dimensions: 53x53x28 (WxHxD)

Note: For installation in a double box or an electronic box (Kaiser). There must be a minimum gap of 4mm between the 230V connection and the connection for the KNX/Inputs (SELV)

Switch actuators

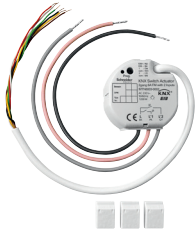

2-gang switch actuator 6 A FM with 2 inputs



Version

Art. no.

MTN6003-0002

2-gang switch actuator with two inputs for installation in a size 60 switch box. Floating contacts can be connected to the two inputs.

The inputs have already been assigned to the corresponding actuators at the factory, enabling operation without programming.

Connection to 230 V via a flexible cable, approx. 20 cm long. The inputs and the KNX are connected via a 6-core, approx. 30 cm long, connecting cable. The connecting cable for the inputs can be extended to a max. of 5 m.

KNX software functions: Switch actuator functions:

Operation as break contact or make contact. Selection of default position on bus voltage failure/recovery. Switch on and/or off delay. Time switch function. Switching. Status feedback. Logic operation. Disable function or priority control. Status feedback object can be inverted.

Input function:

Free assignment of the switching, dimming, blind and valuator functions. Locking object.

Behaviour when bus voltage recovers.

Switching: two switch objects per input. Command on rising/falling edge (ON, OFF, TOGGLE, no reaction).

Dimming: Single surface and dual-surface operation. Time between dimming and switching and dim step values. Telegram repetition and send stop telegram.

Blinds: Command on rising edge (none, UP, DOWN, TOGGLE), Operation concept (Step - Move - Step or Move - Step). Time between short and long operation. Slat adjustment time.

Valuator and Scene ext. input: Edge (push-button as make contact, push-button as break contact, switch) and value on edge. Value adjustment via long push-button action for valuator.

Scene ext. unit with memory function.

Nominal voltage: AC 230 V

Nominal current: 6 A, ohmic load

Switch contacts: 2x make contacts

Nominal output

Incandescent lamps: AC 230 V, max. 1200 W

Halogen lamps: AC 230 V, max. 1200 W

LV halogen lamps: max. 500 VA, wound transformer

max. 500 W, electronic transformers

Capacitive load: AC 230 V, 6 A, max. 14 μ F

Inputs: 2

Temperature range: -5 °C to 45 °C

Type of protection: IP 20

Dimensions: 53x53x28 (WxHxD)

Note: For installation in a double box or an electronic box (Kaiser). There must be a minimum gap of 4mm between the 230V connection and the connection for the KNX/Inputs (SELV)

Switch actuators



Switch actuator REG-K/2x230/10 with manual mode



Version	Art. no.
light grey	MTN649202

For independent switching of up to 2 loads via make contacts. The function of the switching channels is freely configurable. All switching outlets can be operated manually using push-button operation.

Channel status display via LEDs. A green LED indicates readiness for operation.

With integrated bus coupler. For installation on DIN rails TH35 according to EN 60715. The bus is connected using a bus connecting terminal; a data rail is not necessary.

KNX software functions: Operation as break contact/make contact. Programmable behaviour for download. Delay functions for each channel. Staircase lighting function with/without manual OFF function. Cut-out warning for staircase lighting function. Scenes. Central function. Disable function. Logic operation or priority control. Status feedback function for each channel.

Power supply:

Nominal voltage: AC 230 V, 50-60 Hz

For each switch output:

Nominal current: 10 A, $\cos\phi = 1$; 10 A, $\cos\phi = 0.6$

Incandescent lamps: AC 230 V, max. 2000 W

Halogen lamps: AC 230 V, max. 1700 W

Fluorescent lamps: AC 230 V, max. 1800 W, uncompensated

AC 230 V, max. 1000 W with parallel compensation

Capacitive load: AC 230 V, max. 105 μF

Device width: 2.5 modules = approx. 45 mm

Contents: With bus connecting terminal and cable cover.



KNX Switch Actuator Basic REG-K/2x/16 A with manual mode



Version	Art. no.
	MTN6700-0002

For independent switching of 2 loads via make contacts. All switch outputs can be operated with manual switches. With integrated bus coupling unit.

A green LED indicates readiness for operation after the application has been loaded.

For installation on DIN rails TH35 according to EN 60715. The bus is connected using a bus connecting terminal; a data rail is not necessary.

KNX software functions: Staircase lighting function with/without manual OFF function, cut-out warning for staircase lighting function, logic operation, status feedback per channel, central function, parameterisation for bus voltage failure and recovery.

Rated voltage (nominal voltage): AC 100-240 V, 50-60 Hz

Tolerance range: min. AC 90 V - max. AC 265 V

For each switching contact:

Nominal current: 16 A, inductive load $\cos\phi = 0,6$

Nominal load

Incandescent lamps: AC 100 V, max. 1600 W

AC 230 V, max. 3600 W

AC 240 V, max. 3840 W

Halogen lamps: AC 100 V, max. 1080 W

AC 230 V, max. 2500 W

AC 240 V, max. 2500 W

Fluorescent lamps: AC 100 V, max. 900 VA

AC 230 V, max. 2000 VA

AC 240 V, max. 2000 VA

parallel-compensated

Capacitive load: AC 230 V, 16 A, max. 105 μF

Device width: 2.5 modules = approx. 45 mm

Contents: With bus connecting terminal and cable cover.

Switch actuators



Switch actuator REG-K/2x230/16 with manual mode



Version	Art. no.
light grey	MTN647393

For independent switching of two loads via make contacts. With integrated bus coupler and screw terminals. The 230 V switch output can be operated with a manual switch.

A green LED indicates readiness for operation after the application has been loaded.

For installation on DIN rails TH35 according to EN 60715. The bus is connected using a bus connecting terminal; a data rail is not necessary.

KNX software functions: Operation as break or make contact, delay functions for each channel, staircase lighting function with/without manual OFF function, cut-out warning for staircase lighting function, blocking and additional logic operation or priority control, scenes, status feedback function per channel, central function, comprehensive parameterisation for bus voltage failure and recovery, parameterisable download behaviour.

Nominal voltage: AC 100-240 V $\pm 10\%$

Operating voltage: min. AC 90 V - max. AC 265 V

Mains frequency: 50-60 Hz $\pm 10\%$

For each switching contact:

Switching current: 16 A, $\cos\phi = 0.6$

AC1 operation: max. 16 A

AC3 operation: max. 10 A

AC5 operation: max. 16 A

DC current switching capacity: max. 16 A / 24 V DC

Output life endurance:

Mechanical: $>10^6$

AC1/AC3/AC5 operation: $>3 \times 10^4$

230V, 1A resistive: $>8 \times 10^5$

Nominal load

Incandescent lamps: AC 100 V, max. 1600 W

AC 230 V, max. 3600 W

AC 240 V, max. 3840 W

Halogen lamps: AC 100 V, max. 1086 W

AC 230 V, max. 2500 W

AC 240 V, max. 2608 W

Fluorescent lamps: AC 100 V, max. 1086 VA

AC 230 V, max. 2500 VA

AC 240 V, max. 2608 VA

parallel-compensated

Capacitive load: AC 230 V, 16 A, max. 200 μF

Minimum switching performance: 100 mA/12 V AC/DC

Maximum peak inrush-current:

150 μs : 600 A

250 μs : 480 A

600 μs : 300 A

Device width: 2.5 modules = approx. 45 mm

Contents: With bus connecting terminal and cable cover.

Switch actuators



Switch actuator REG-K/2x230/16 with manual mode and current detection

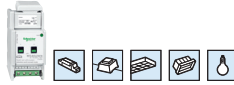

Version	Art. no.
light grey	MTN647395

For independent switching of two loads via make contacts. The actuator has integrated current detection that measures the load current on each channel. All 230 V switch outputs can be operated with manual switches. With integrated bus coupling unit.

A green LED indicates that the device is ready for operation once the application has been loaded. The load is connected with screw terminals.

For installation on DIN rails TH35 according to EN 60715. The bus is connected using a bus connecting terminal; a data rail is not necessary.

KNX software functions: Operation as break contact or make contact. Staircase lighting function with/without manual OFF function and switch-off warning. Delay functions. Scenes. Logic function. Blocking or priority control. Feedback function. Status. Central function with delay. Parameterisation for bus voltage failure and recovery. Behaviour for download.

Current detection function: Behaviour when value exceeds/falls short of the threshold value. Energy, operating and switch on counter with limit value monitoring.

Flash function.

Nominal voltage: AC 100-240 V $\pm 10\%$

DC 12-24 V, 0.1-16 A

Operating voltage: min. AC 90 V - max. AC 265 V

Mains frequency: 50-60 Hz $\pm 10\%$

For each switching contact:

Switching current: 16 A, $\cos\phi = 0.6$

AC1 operation: max. 16 A

AC3 operation: max. 10 A

AC5 operation: max. 16 A

DC current switching capacity: max. 16 A / 24 V DC

Output life endurance:

Mechanical: $>10^6$

AC1/AC3/AC5 operation: $>3 \times 10^4$

230V, 1A resistive: $>8 \times 10^5$

Nominal load

Incandescent lamps: AC 100 V, max. 1600 W

AC 230 V, max. 3600 W

AC 240 V, max. 3840 W

Halogen lamps: AC 100 V, max. 1086 W

AC 230 V, max. 2500 W

AC 240 V, max. 2608 W

Fluorescent lamps: AC 100 V, max. 1086 VA

AC 230 V, max. 2500 VA

AC 240 V, max. 2608 VA

parallel-compensated

Capacitive load: AC 230 V, 16 A, max. 200 μF

Motor load: AC 100 V, max. 434 W

AC 230 V, max. 1000 W

AC 240 V, max. 1043 W

Minimum switching performance: 100 mA/12 V AC/DC

Maximum peak inrush-current:

150 μs : 600 A

250 μs : 480 A

600 μs : 300 A

Current detection (load current):

Detection range: 0.1 A to 16 A (sine effective value or DC)

Sensing accuracy: $\pm 8\%$ of the current value at hand (sine) and ± 100 mA

Frequency: 50/60 Hz, for alternating current (AC)

Description: 100 mA

Device width: 2.5 modules = approx. 45 mm

Contents: With bus connecting terminal and cable cover.

Switch actuators



Switch actuator REG-K/4x230/10 with manual mode



Version	Art. no.
light grey	MTN649204

For independent switching of up to 4 loads via make contacts. The function of the switching channels is freely configurable. All switching outlets can be operated manually using push-button operation.

Channel status display via LEDs. A green LED indicates readiness for operation.

With integrated bus coupler. For installation on DIN rails TH35 according to EN 60715. The bus is connected using a bus connecting terminal; a data rail is not necessary.

KNX software functions: Operation as break contact/make contact. Programmable behaviour for download. Delay functions for each channel. Staircase lighting function with/without manual OFF function. Cut-out warning for staircase lighting function. Scenes. Central function. Disable function. Logic operation or priority control. Status feedback function for each channel.

Power supply:

Nominal voltage: AC 230 V, 50-60 Hz

For each switch output:

Nominal current: 10 A, $\cos\phi = 1$; 10 A, $\cos\phi = 0.6$

Incandescent lamps: AC 230 V, max. 2000 W

Halogen lamps: AC 230 V, max. 1700 W

Fluorescent lamps: AC 230 V, max. 1800 W, uncompensated

AC 230 V, max. 1000 W with parallel compensation

Capacitive load: AC 230 V, max. 105 μF

Device width: 4 modules = approx. 72 mm

Contents: With bus connecting terminal and cable cover.



KNX Switch Actuator Basic REG-K/4x16 A with manual mode



Version	Art. no.
	MTN6700-0004

For independent switching of 4 loads via make contacts. All switch outputs can be operated with manual switches. With integrated bus coupling unit.

A green LED indicates readiness for operation after the application has been loaded.

For installation on DIN rails TH35 according to EN 60715. The bus is connected using a bus connecting terminal; a data rail is not necessary.

KNX software functions: Staircase lighting function with/without manual OFF function, cut-out warning for staircase lighting function, logic operation, status feedback per channel, central function, parameterisation for bus voltage failure and recovery.

Rated voltage (nominal voltage): AC 100-240 V, 50-60 Hz

Tolerance range: min. AC 90 V - max. AC 265 V

For each switching contact:

Nominal current: 16 A, inductive load $\cos\phi = 0,6$

Nominal load

Incandescent lamps: AC 100 V, max. 1600 W

AC 230 V, max. 3600 W

AC 240 V, max. 3840 W

Halogen lamps: AC 100 V, max. 1080 W

AC 230 V, max. 2500 W

AC 240 V, max. 2500 W

Fluorescent lamps: AC 100 V, max. 900 VA

AC 230 V, max. 2000 VA

AC 240 V, max. 2000 VA

parallel-compensated

Capacitive load: AC 230 V, 16 A, max. 105 μF

Device width: 4 modules = approx. 72 mm

Contents: With bus connecting terminal and cable cover.

Switch actuators



Switch actuator REG-K/4x230/16 with manual mode



Version	Art. no.
light grey	MTN647593

For independent switching of four loads via make contacts. With integrated bus coupler 2 and screw terminals. The 230 V switch output can be operated with a manual switch. A green LED indicates readiness for operation after the application has been loaded.

For installation on DIN rails TH35 according to EN 60715. The bus is connected using a bus connecting terminal; a data rail is not necessary.

KNX software functions: Operation as break or make contact, delay functions for each channel, staircase lighting function with/without manual OFF function, cut-out warning for staircase lighting function, blocking and additional logic operation or priority control, scenes, status feedback function per channel, central function, comprehensive parameterisation for bus voltage failure and recovery, parameterisable download behaviour.

Nominal voltage: 230 V AC, 50-60 Hz

For each switching contact: Switching current: 16 A, $\cos\phi=0.6$

AC1 operation: max. 16 A

AC3 operation: max. 10 A

AC5 operation: max. 16 A

DC current switching capacity: max. 16 A / 24 V DC

Output life endurance:

Mechanical: $>10^6$

AC1/AC3/AC5 operation: $>3 \times 10^4$

230V, 1A resistive: $>8 \times 10^5$ **Incandescent lamps:** 230 V AC, max. 3600 W

Halogen lamps: 230 V AC, max. 2500 W

Fluorescent lamps: AC 230 V, max. 2500 VA

Capacitive load: 230 V AC, 16 A, max. 200 μ F

Minimum switching performance: 100 mA/12 V AC/DC

Maximum peak inrush-current:

150 μ s: 600 A

250 μ s: 480 A

600 μ s: 300 A

Device width: 4 modules = approx. 72 mm

Contents: With bus connecting terminal and cable cover.

Switch actuators



Switch actuator REG-K/4x230/16 with manual mode and current detection



Version	Art. no.
light grey	MTN647595

For independent switching of four loads via make contacts. The actuator has integrated current detection that measures the load current on each channel. All 230 V switch outputs can be operated with manual switches. With integrated bus coupling unit.

A green LED indicates that the device is ready for operation once the application has been loaded. The load is connected with screw terminals.

For installation on DIN rails TH35 according to EN 60715. The bus is connected using a bus connecting terminal; a data rail is not necessary.

KNX software functions: Operation as break contact or make contact. Staircase lighting function with/without manual OFF function and switch-off warning. Delay functions. Scenes. Logic function. Blocking or priority control. Feedback function. Status. Central function with delay. Parameterisation for bus voltage failure and recovery. Behaviour for download.

Current detection function: Behaviour when value exceeds/falls short of the threshold value. Energy, operating and switch on counter with limit value monitoring.

Flash function.

Nominal voltage: 230 V AC, 50-60 Hz

DC 12-24 V ±10%, 0.1-16 A

For each switching contact: Switching current: 16 A, cosφ= 0.6

AC1 operation: max. 16 A

AC3 operation: max. 10 A

AC5 operation: max. 16 A

DC current switching capacity: max. 16 A/ 24 V DC

Output life endurance:

Mechanical: >10⁶

AC1/AC3/AC5 operation: >3x10⁴

230V, 1A resistive: >8x10⁵ **Incandescent lamps:** 230 V AC, max. 3600 W

Halogen lamps: 230 V AC, max. 2500 W

Fluorescent lamps: 230 V AC, max. 2500 VA, with parallel compensation

Capacitive load: 230 V AC, 16 A, max. 200 µF

Minimum switching performance: 100 mA/12 V AC/DC

Maximum peak inrush-current:

150µs: 600 A

250µs: 480 A

600µs: 300 A

Current detection load current: Detection range: 0.1 A to 16 A (sine effective value or direct current)

Detection accuracy: +/- 8% of the present current value (sine) and +/- 100 mA

Frequency: 50/60 Hz with alternating voltage

Display: 100 mA

Device width: 4 modules = approx. 72 mm

Contents: With bus connecting terminal and cable cover.

Switch actuators



Switch actuator REG-K/8x230/6

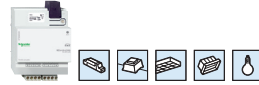

Version	Art. no.
light grey	MTN646808

For independent switching of eight loads via make contacts. With integrated bus coupler and plug-in screw terminals.

A green LED indicates readiness for operation after the application has been loaded.

For installation on DIN rails TH35 according to EN 60715. The bus is connected using a bus connecting terminal; a data rail is not necessary.

KNX software functions: Operation as break or make contact, delay functions for each channel, staircase lighting function with/without manual OFF function, cut-out warning for staircase lighting function, blocking and additional logic operation or priority control, scenes, status feedback function per channel, central function, comprehensive parameterisation for bus voltage failure and recovery, parameterisable download behaviour.

Nominal voltage: AC 230 V, 50-60 Hz

For each switching contact:

Nominal current: 6 A, $\cos\phi = 0.6$

Incandescent lamps: AC 230 V, max. 1380 W

Halogen lamps: AC 230 V, max. 1380 W

Fluorescent lamps: AC 230 V, max. 1000 VA

Capacitive load: AC 230 V, 6 A, max. 105 μF

Device width: 4 modules = approx. 72 mm

Contents: With bus connecting terminal and cable cover.



Switch actuator REG-K/8x230/10 with manual mode



Version	Art. no.
light grey	MTN649208

For independent switching of up to 8 loads via make contacts. The function of the switching channels is freely configurable. All switching outlets can be operated manually using push-button operation.

Channel status display via LEDs. A green LED indicates readiness for operation.

With integrated bus coupler. For installation on DIN rails TH35 according to EN 60715. The bus is connected using a bus connecting terminal; a data rail is not necessary.

KNX software functions: Operation as break contact/make contact. Programmable behaviour for download. Delay functions for each channel. Staircase lighting function with/without manual OFF function. Cut-out warning for staircase lighting function. Scenes. Central function. Disable function. Logic operation or priority control. Status feedback function for each channel.

Power supply:

Nominal voltage: AC 230 V, 50-60 Hz

For each switch output:

Nominal current: 10 A, $\cos\phi = 1$; 10 A, $\cos\phi = 0.6$

Incandescent lamps: AC 230 V, max. 2000 W

Halogen lamps: AC 230 V, max. 1700 W

Fluorescent lamps: AC 230 V, max. 1800 W, uncompensated

AC 230 V, max. 1000 W with parallel compensation

Capacitive load: AC 230 V, max. 105 μF

Device width: 4 modules = approx. 72 mm

Contents: With bus connecting terminal and cable cover.

Switch actuators



KNX Switch Actuator Basic REG-K/8x/16 A with manual mode



Version

Art. no.

MTN6700-0008

For independent switching of 8 loads via make contacts. All switch outputs can be operated with manual switches. With integrated bus coupler.

A green LED indicates readiness for operation after the application has been loaded.

For installation on DIN rails TH35 according to EN 60715. The bus is connected using a bus connecting terminal; a data rail is not necessary.

KNX software functions: Staircase lighting function with/without OFF function, cut-out warning for staircase lighting function, logic operation, status feedback per channel, central function, parameterisation for bus voltage failure and recovery.

Rated voltage (nominal voltage): AC 100-240 V, 50-60 Hz

Tolerance range: min. AC 90 V - max. AC 265 V

For each switching contact:

Nominal current: 16 A, inductive load $\cos\phi = 0,6$

Nominal load

Incandescent lamps: AC 100 V, max. 1600 W

AC 230 V, max. 3600 W

AC 240 V, max. 3840 W

Halogen lamps: AC 100 V, max. 1080 W

AC 230 V, max. 2500 W

AC 240 V, max. 2500 W

Fluorescent lamps: AC 100 V, max. 900 VA

AC 230 V, max. 2000 VA

AC 240 V, max. 2000 VA

parallel-compensated

Capacitive load: AC 230 V, 16 A, max. 105 μF

Device width: 8 modules = approx. 144 mm

Contents: With bus connecting terminal and cable cover.

Switch actuators



Switch actuator REG-K/8x230/16 with manual mode



Version	Art. no.
light grey	MTN647893

For independent switching of 8 loads via make contacts. All 230 V switch outputs can be operated with manual switches. With integrated bus coupler.

The device is connected to the mains via screw terminals; every second L connection is bridged internally. A green LED indicates readiness for operation after the application has been loaded.

For installation on DIN rails TH35 according to EN 60715. The bus is connected using a bus connecting terminal; a data rail is not necessary.

KNX software functions: Operation as break or make contact, delay functions for each channel, staircase lighting function with/without manual OFF function, cut-out warning for staircase lighting function, blocking and additional logic operation or priority control, scenes, status feedback function per channel, central function, comprehensive parameterisation for bus voltage failure and recovery, parameterisable download behaviour.

Nominal voltage: AC 100-240 V $\pm 10\%$

Operating voltage: min. AC 90 V - max. AC 265 V

Mains frequency: 50-60 Hz $\pm 10\%$

For each switching contact:

Switching current: 16 A, $\cos\phi = 0.6$

AC1 operation: max. 16 A

AC3 operation: max. 10 A

AC5 operation: max. 16 A

DC current switching capacity: max. 16 A / 24 V DC

Output life endurance:

Mechanical: $>10^6$

AC1/AC3/AC5 operation: $>3 \times 10^4$

230V, 1A resistive: $>8 \times 10^5$

Nominal load

Incandescent lamps: AC 100 V, max. 1600 W

AC 230 V, max. 3600 W

AC 240 V, max. 3840 W

Halogen lamps: AC 100 V, max. 1086 W

AC 230 V, max. 2500 W

AC 240 V, max. 2608 W

Fluorescent lamps: AC 100 V, max. 1086 VA

AC 230 V, max. 2500 VA

AC 240 V, max. 2608 VA

parallel-compensated

Capacitive load: AC 230 V, 16 A, max. 200 μF

Minimum switching performance: 100 mA/12 V AC/DC

Maximum peak inrush-current:

150 μs : 600 A

250 μs : 480 A

600 μs : 300 A

Device width: 8 modules = approx. 144 mm

Contents: With bus connecting terminal and cable cover.

Switch actuators



Switch actuator REG-K/8x230/16 with manual mode and current detection



Version	Art. no.
light grey	MTN647895

For independently switching 8 loads via make contacts. The actuator has integrated current detection that measures the load current on each channel. All 230 V switch outputs can be operated with manual switches. With integrated bus coupling unit.

A green LED indicates that the device is ready for operation once the application has been loaded. The load is connected with screw terminals.

For installation on DIN rails TH35 according to EN 60715. The bus is connected using a bus connecting terminal; a data rail is not necessary.

KNX software functions: Operation as break contact or make contact. Staircase lighting function with/without manual OFF function and switch-off warning. Delay functions. Scenes. Logic function. Blocking or priority control. Feedback function. Status. Central function with delay. Parameterisation for bus voltage failure and recovery. Behaviour for download.

Current detection function: Behaviour when value exceeds/falls short of the threshold value. Energy, operating and switch on counter with limit value monitoring.

Flash function.

Nominal voltage: AC 100-240 V $\pm 10\%$

DC 12-24 V, 0.1-16 A

Operating voltage: min. AC 90 V - max. AC 265 V

Mains frequency: 50-60 Hz $\pm 10\%$

For each switching contact:

Switching current: 16 A, $\cos\phi = 0.6$

AC1 operation: max. 16 A

AC3 operation: max. 10 A

AC5 operation: max. 16 A

DC current switching capacity: max. 16 A / 24 V DC

Output life endurance:

Mechanical: $>10^6$

AC1/AC3/AC5 operation: $>3 \times 10^4$

230V, 1A resistive: $>8 \times 10^5$

Nominal load

Incandescent lamps: AC 100 V, max. 1600 W

AC 230 V, max. 3600 W

AC 240 V, max. 3840 W

Halogen lamps: AC 100 V, max. 1086 W

AC 230 V, max. 2500 W

AC 240 V, max. 2608 W

Fluorescent lamps: AC 100 V, max. 1086 VA

AC 230 V, max. 2500 VA

AC 240 V, max. 2608 VA

parallel-compensated

Capacitive load: AC 230 V, 16 A, max. 200 μF

Motor load: AC 100 V, max. 434 W

AC 230 V, max. 1000 W

AC 240 V, max. 1043 W

Minimum switching performance: 100 mA/12 V AC/DC

Maximum peak inrush-current:

150 μs : 600 A

250 μs : 480 A

600 μs : 300 A

Current detection (load current):

Detection range: 0.1 A to 16 A (sine effective value or DC)

Sensing accuracy: $\pm 8\%$ of the current value at hand (sine) and ± 100 mA

Frequency: 50/60 Hz, for alternating current (AC)

Description: 100 mA

Device width: 8 modules = approx. 144 mm

Contents: With bus connecting terminal and cable cover.

Switch actuators

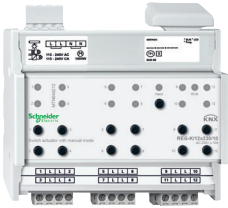

Switch actuator REG-K/12x230/10 with manual mode

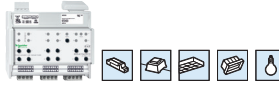

Version	Art. no.
light grey	MTN649212

For independent switching of up to 12 loads via make contacts. The function of the switching channels is freely configurable. All switching outlets can be operated manually using push-button operation.

Channel status display via LEDs. A green LED indicates readiness for operation. With integrated bus coupler. For installation on DIN rails TH35 according to EN 60715. The bus is connected using a bus connecting terminal; a data rail is not necessary.

KNX software functions: Operation as break contact/make contact. Programmable behaviour for download. Delay functions for each channel. Staircase lighting function with/without manual OFF function. Cut-out warning for staircase lighting function. Scenes. Central function. Disable function. Logic operation or priority control. Status feedback function for each channel.

Power supply:

Nominal voltage: AC 230 V, 50 - 60 Hz

External auxiliary voltage (optional): AC 110 - 240 V, 50 - 60 Hz, max. 2 VA

For each switch output:

Nominal current: 10 A, $\cos\phi = 1$; 10 A, $\cos\phi = 0.6$

Incandescent lamps: AC 230 V, max. 2000 W

Halogen lamps: AC 230 V, max. 1700 W

Fluorescent lamps: AC 230 V, max. 1800 W, uncompensated

AC 230 V, max. 1000 W parallel-compensated

Capacitive load: AC 230 V, max. 105 μF

Device width: 6 modules = approx. 108 mm

Contents: With bus connecting terminal and cable cover.



KNX Switch Actuator Basic REG-K/12x/16 A with manual mode



Version	Art. no.
	MTN6700-0012

For independent switching of 12 loads via make contacts. All switch outputs can be operated with manual switches. With integrated bus coupler.

A green LED indicates readiness for operation after the application has been loaded.

For installation on DIN rails TH35 according to EN 60715. The bus is connected using a bus connecting terminal; a data rail is not necessary.

KNX software functions: Staircase lighting function with/without manual OFF function, cut-out warning for staircase lighting function, logic operation, status feedback per channel, central function, parameterisation for bus voltage failure and recovery.

Rated voltage (nominal voltage): AC 100-240 V, 50-60 Hz

Tolerance range: min. AC 90 V - max. AC 265 V

For each switching contact:

Nominal current: 16 A, inductive load $\cos\phi = 0.6$

Nominal load

Incandescent lamps: AC 100 V, max. 1600 W

AC 230 V, max. 3600 W

AC 240 V, max. 3840 W

Halogen lamps: AC 100 V, max. 1080 W

AC 230 V, max. 2500 W

AC 240 V, max. 2500 W

Fluorescent lamps: AC 100 V, max. 900 VA

AC 230 V, max. 2000 VA

AC 240 V, max. 2000 VA

parallel-compensated

Capacitive load: AC 230 V, 16 A, max. 105 μF

Device width: 12 modules = approx. 216 mm

Contents: With bus connecting terminal and cable cover.

Switch actuators



Switch actuator REG-K/12x230/16 with manual mode



Version	Art. no.
light grey	MTN648493

For independent switching of 12 loads via make contacts. All 230 V switch outputs can be operated with manual switches. With integrated bus coupler.

The device is connected to the mains via screw terminals; every second L connection is bridged internally. A green LED indicates readiness for operation after the application has been loaded.

For installation on DIN rails TH35 according to EN 60715. The bus is connected using a bus connecting terminal; a data rail is not necessary.

KNX software functions: Operation as break or make contact, delay functions for each channel, staircase lighting function with/without manual OFF function, cut-out warning for staircase lighting function, blocking and additional logic operation or priority control, scenes, status feedback function per channel, central function, comprehensive parameterisation for bus voltage failure and recovery, parameterisable download behaviour.

Nominal voltage: 230 V AC, 50-60 Hz

For each switching contact: Switching current: 16 A, $\cos\phi=0.6$

AC1 operation: max. 16 A

AC3 operation: max. 10 A

AC5 operation: max. 16 A

DC current switching capacity: max. 16 A/ 24 V DC

Output life endurance:

Mechanical: $>10^6$

AC1/AC3/AC5 operation: $>3 \times 10^4$

230V, 1A resistive: $>8 \times 10^5$ **Incandescent lamps:** 230 V AC, max. 3600 W

Halogen lamps: 230 V AC, max. 2500 W

Fluorescent lamps: AC 230 V, max. 2500 VA

Capacitive load: 230 V AC, 16 A, max. 200 μ F

Minimum switching performance: 100 mA/12 V AC/DC

Maximum peak inrush-current:

150 μ s: 600 A

250 μ s: 480 A

600 μ s: 300 A

Device width: 12 modules = approx. 216 mm

Contents: With bus connecting terminal and cable cover.

Switch actuators



Switch actuator REG-K/12x230/16 with manual mode and current detection



Version	Art. no.
---------	----------

light grey

MTN648495

For independently switching 12 loads via make contacts. The actuator has integrated current detection that measures the load current on each channel. All 230 V switch outputs can be operated with manual switches. With integrated bus coupling unit.

A green LED indicates that the device is ready for operation once the application has been loaded. The load is connected with screw terminals.

For installation on DIN rails TH35 according to EN 60715. The bus is connected using a bus connecting terminal; a data rail is not necessary.

KNX software functions: Operation as break contact or make contact. Staircase lighting function with/without manual OFF function and switch-off warning. Delay functions. Scenes. Logic function. Blocking or priority control. Feedback function. Status. Central function with delay. Parameterisation for bus voltage failure and recovery. Behaviour for download.

Current detection function: Behaviour when value exceeds/falls short of the threshold value. Energy, operating and switch on counter with limit value monitoring.

Flash function.

Nominal voltage: AC 100-240 V $\pm 10\%$

DC 12-24 V, 0.1-16 A

Operating voltage: min. AC 90 V - max. AC 265 V

Mains frequency: 50-60 Hz $\pm 10\%$

For each switching contact:

Switching current: 16 A, $\cos\phi = 0.6$

AC1 operation: max. 16 A

AC3 operation: max. 10 A

AC5 operation: max. 16 A

DC current switching capacity: max. 16 A / 24 V DC

Output life endurance:

Mechanical: $>10^6$

AC1/AC3/AC5 operation: $>3 \times 10^4$

230V, 1A resistive: $>8 \times 10^5$

Nominal load

Incandescent lamps: AC 100 V, max. 1600 W

AC 230 V, max. 3600 W

AC 240 V, max. 3840 W

Halogen lamps: AC 100 V, max. 1086 W

AC 230 V, max. 2500 W

AC 240 V, max. 2608 W

Fluorescent lamps: AC 100 V, max. 1086 VA

AC 230 V, max. 2500 VA

AC 240 V, max. 2608 VA

parallel-compensated

Capacitive load: AC 230 V, 16 A, max. 200 μF

Motor load: AC 100 V, max. 434 W

AC 230 V, max. 1000 W

AC 240 V, max. 1043 W

Minimum switching performance: 100 mA/12 V AC/DC

Maximum peak inrush-current:

150 μs : 600 A

250 μs : 480 A

600 μs : 300 A

Current detection (load current):

Detection range: 0.1 A to 16 A (sine effective value or DC)

Sensing accuracy: $\pm 8\%$ of the current value at hand (sine) and ± 100 mA

Frequency: 50/60 Hz, for alternating current (AC)

Description: 100 mA



Device width: 12 modules = approx. 216 mm

Contents: With bus connecting terminal and cable cover.

KNX



Overview rail mounted devices

blind actuators

	Blind actuator REG-K/4x/6	Blind actuator REG-K/4x24/6 with manual mode	Roller shutter actuator REG-K/4x/10 with manual mode	
				
Article number	MTN646704	MTN648704	MTN649704	
Number of channels	4	4	4	
Device width	4 modules	4 modules	4 modules	
Manual mode push-buttons	—	■	■	
Connecting terminal (consumer load)	Plug-in screw terminals	Plug-in screw terminals	Plug-in screw terminals	
Nominal voltage, AC, 50-60 Hz	AC 230 V	—	AC 100-240 V	
Nominal voltage, DC	—	DC 24 V, ±10 %	—	
Nominal current	6 A, cosφ = 0,6	6 A	10 A, cosφ = 0,6	
Auxiliary power (optional)	—	—	—	
Software				
Configuration switching or blind	—	—	—	
Defining blind type	■	■	—	
Slat functionality	■	■	—	
Calibration (reference movement)	■	■	■	
Movement range limit	■	■	■	
Pause on reverse on change in direction	■	■	■	
Extended drive parameters	■	■	■	
Control by				
■ manual mode via the push-buttons of the actuator	—	■	■	
■ automatic objects or preset objects	■	■	■	
■ manual operation via objects	■	■	■	
Manual mode enable/disable when bus voltage fails	—	—	—	
Locking manual operation via objects	■	■	■	
Weather alarm functions				
■ Wind alarm	3	3	3	
■ Rain alarm	1	1	1	
■ Frost alarm	1	1	1	
■ Set the order of priority	■	■	■	
■ Behaviour at start/end of the wether alarm	■	■	■	
Alarm functions				
■ Behavior at the start/end of the alarm	■	■	■	
Set the order of priority for higher-level functions (alarm, weather alarm, locking, movement range)	■	■	■	
Scenes	4	5	5	
Disable function				
■ Behavior at the start/end of the locking	■	■	■	
Behaviour of bus voltage failure / bus voltage recovery / download	■ / ■ / ■	■ / ■ / ■	■ / ■ / ■	
Status messages				
■ Hight	■	■	■	
■ Slat	■	■	—	
■ Automatic	■	■	■	
■ Drive locking or movement range limit	■	■	■	

KNX

Overview rail mounted devices blind actuators

	Blind actuator REG-K/x/10 with manual mode	Blind actuator REG-K/8x/10 with manual mode	Blind/switch actuator REG-K/x/x/10 with manual mode
	 MTN649802	 MTN649808	 MTN649908
	2	8	8
	4	8	12
	4 modules	8 modules	8 modules 12 modules
	■	■	■
	Plug-in screw terminals	Plug-in screw terminals	Plug-in screw terminals
	AC 100-240 V	AC 230 V	AC 100-240 V
	—	—	—
	10 A, cosφ = 0,6	10 A, cosφ = 0,6	10 A, cosφ = 0,6
	—	AC 110-240 V, 50-60 Hz, max. 2 VA	AC 110-240 V, 50-60 Hz, max. 2 VA
	—	—	■
	■	■	■
	■	■	■
	■	■	■
	■	■	—
	■	■	■
	■	■	■
	■	■	■
	■	■	■
	■	■	■
	■	■	■
	■	■	■
	■	■	■
	■	■	■
	■	■	■
	■	■	■
	■	■ (Precondition: auxiliary power)	■ (Precondition: auxiliary power)
	■	■	—
	3	3	1
	1	1	1
	1	1	—
	■	■	■
	■	■	■
	■	■	—
	■	■	—
	5	5	5
	■	■	—
	■ / ■ / ■	■ / ■ / ■	■ / ■ / ■
	■	■	■
	■	■	■
	■	■	■
	■	■	—

Blind/switch actuators



Blind/switch actuator REG-K/8x/16x/10 with manual mode

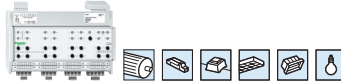

Version	Art. no.
---------	----------

light grey	MTN649908
------------	------------------

For independent control of up to 8 blind/roller shutter drives or for switching up to 16 loads via make contacts. The function of the blind or switching channels is freely configurable. All blind/switch outputs can be operated manually using push-buttons.

The bus is connected using a bus connecting terminal; a data rail is not necessary. Channel status display via LEDs. A green LED indicates readiness for operation.

With integrated bus coupler. For installation on DIN rails TH35 according to EN 60715. The bus is connected using a bus connecting terminal; a data rail is not necessary.

KNX software functions: Blind functions: Blind type. Running time. Idle time. Step interval. Weather alarm. 8-bit positioning for height and slats. Scenes. Status and feedback function.

Switch actuator functions: Operation as break contact/make contact. Programmable behaviour for download. Delay functions for each channel. Staircase lighting function with/without manual OFF function. Cut-out warning for staircase lighting function. Scenes. Central function. Disable function. Logic operation or priority control. Status feedback function for each channel.

Nominal voltage: AC 100-240 V $\pm 10\%$

Operating voltage: min. AC 90 V - max. AC 265 V

Mains frequency: 50-60 Hz $\pm 10\%$

For each blind output:

Nominal current: 10 A, inductive load $\cos\phi = 0.6$

Motor load: AC 100 V, max. 434 W

AC 230 V, max. 1000 W

AC 240 V, max. 1043 W

For each switch output:

Nominal current: 10 A, ohmic load $\cos\phi = 1$

10 A, inductive load $\cos\phi = 0.6$

Nominal load

Incandescent lamps: AC 100 V, max. 869 W

AC 230 V, max. 2000 W

AC 240 V, max. 2086 W

Halogen lamps: AC 100 V, max. 739 W

AC 230 V, max. 1700 W

AC 240 V, max. 1773 W

Fluorescent lamps: AC 100 V, max. 434 VA

AC 230 V, max. 1000 VA

AC 240 V, max. 1043 VA

parallel-compensated

Capacitive load: AC 230 V, 10 A, max. 105 μF

External auxiliary voltage (optional):

Nominal voltage: AC 110-240 V $\pm 10\%$

Operating voltage: min. AC 92 V - max. AC 265 V

Device width: 8 modules = approx. 144 mm

Note: The blind actuator/switch actuator cannot be used in conjunction with the weather-dependent automatic functions of the weather combi-sensor/DCF77 art. no. MTN663692. If you require these functions then use the blind actuators art. no. MTN6498...

Contents: With bus connecting terminal and cable cover.

Blind/switch actuators



Blind / switch actuator REG-K/12x/24x/10 with manual mode



Version	Art. no.
light grey	MTN649912

For independent control of up to 12 blind/roller shutter drives or for switching up to 24 loads via make contacts. The function of the blind or switching channels is freely configurable. All blind/switch outputs can be operated manually using push-buttons.

Channel status display via LEDs. A green LED indicates readiness for operation.

With integrated bus coupler. For installation on DIN rails TH35 according to EN 60715. The bus is connected using a bus connecting terminal; a data rail is not necessary.

KNX software functions: **Blind functions:** Blind type. Running time. Idle time. Step interval. Weather alarm. 8-bit positioning for height and slats. Scenes. Status and feedback function.

Switch actuator functions: Operation as break contact/make contact. Programmable behaviour for download. Delay functions for each channel. Staircase lighting function with/without manual OFF function. Cut-out warning for staircase lighting function. Scenes. Central function. Disable function. Logic operation or priority control. Status feedback function for each channel.

Nominal voltage: AC 100-240 V $\pm 10\%$

Operating voltage: min. AC 90 V - max. AC 265 V

Mains frequency: 50-60 Hz $\pm 10\%$

For each blind output:

Nominal current: 10 A, inductive load $\cos\phi = 0.6$

Motor load: AC 100 V, max. 434 W

AC 230 V, max. 1000 W

AC 240 V, max. 1043 W

For each switch output:

Nominal current: 10 A, ohmic load $\cos\phi = 1$

10 A, inductive load $\cos\phi = 0.6$

Nominal load

Incandescent lamps: AC 100 V, max. 869 W

AC 230 V, max. 2000 W

AC 240 V, max. 2086 W

Halogen lamps: AC 100 V, max. 739 W

AC 230 V, max. 1700 W

AC 240 V, max. 1773 W

Fluorescent lamps: AC 100 V, max. 434 VA

AC 230 V, max. 1000 VA

AC 240 V, max. 1043 VA

parallel-compensated

Capacitive load: AC 230 V, 10 A, max. 105 μF

External auxiliary voltage (optional):

Nominal voltage: AC 110-240 V $\pm 10\%$

Operating voltage: min. AC 92 V - max. AC 265 V

Device width: 12 modules = approx. 216 mm

Note: The blind actuator/switch actuator cannot be used in conjunction with the weather-dependent automatic functions of the weather combi-sensor/DCF77 art. no. MTN663692. If you require these functions then use the blind actuators art. no. MTN6498...

Contents: With bus connecting terminal and cable cover.

Blind actuators



Blind actuator REG-K/2x/10 with manual mode



Version	Art. no.
light grey	MTN649802

For independent control of 2 blind/roller shutter drives. The function of the blind channels is freely configurable. All blind outputs can be operated manually using push-button operation. Channel status display via LEDs. A green LED indicates readiness for operation. With integrated bus coupler. For installation on DIN rails TH35 according to EN 60715. The bus is connected using a bus connecting terminal; a data rail is not necessary.

KNX software functions: Blind functions: Blind type. Running time. Idle time. Step interval. Differentiated disable functions and weather alarms. 8-bit positioning for height and slat. Scenes. Manual/automatic mode. Differentiated status and status feedback functions.

For each blind output:
Nominal voltage: AC 100-240 V $\pm 10\%$
Operating voltage: min. AC 90 V - max. AC 265 V
Mains frequency: 50-60 Hz $\pm 10\%$
Nominal current: 10 A, inductive load $\cos\phi = 0.6$
Motor load: AC 100 V, max. 434 W
 AC 230 V, max. 1000 W
 AC 240 V, max. 1043 W
Device width: 4 modules = approx. 72 mm
Contents: With bus connecting terminal and cable cover.



Blind actuator REG-K/4x24/6 with manual mode



Version	Art. no.
light grey	MTN648704

For independent control of 4 blind/roller shutter drives. The function of the blind channels is freely configurable. All blind outputs can be operated manually using push-button operation. Channel status display via LEDs. A green LED indicates readiness for operation. With integrated bus coupler. For installation on DIN rails TH35 according to EN 60715. The bus is connected using a bus connecting terminal; a data rail is not necessary.

KNX software functions: Blind functions: Blind type. Running time. Idle time. Step interval. Differentiated disable functions and weather alarms. 8-bit positioning for height and slat. Scenes. Manual/automatic mode. Differentiated status and status feedback functions.

For each blind output:
Nominal voltage: DC 24 V $\pm 10\%$
Nominal current: 6 A
Load types: 24 V direct current drives
Device width: 4 modules = approx. 72 mm
Contents: With bus connecting terminal and cable cover.

Blind actuators



Blind actuator REG-K/4x/6



Version	Art. no.
light grey	MTN646704

For independent control of 4 blind/roller shutter drives. With integrated bus coupler and plug-in screw terminals.

A green LED indicates readiness for operation after the application has been loaded.

For installation on DIN rails TH35 according to EN 60715. The bus is connected using a bus connecting terminal; a data rail is not necessary.

KNX software functions: Blind functions: Blind type. Running time. Idle time. Step interval. Weather alarms. 8-bit positioning for height and slats. Scenes. Automatic function. Differentiated status and feedback functions.

For each blind output:

Nominal voltage: AC 230 V, 50-60 Hz

Nominal current: 6 A, $\cos\phi = 0.6$

Motor load: AC 230 V, max. 1000 W

Device width: 4 modules = approx. 72 mm

Contents: With bus connecting terminal and cable cover.



Roller shutter actuator REG-K/4x/10 with manual mode



Version	Art. no.
light grey	MTN649704

For independent control of 4 roller shutter drives. The function of the roller shutter channels is freely configurable. All roller shutter outputs can be operated manually using push-button operation.

Channel status display via LEDs. A green LED indicates readiness for operation.

With integrated bus coupler. For installation on DIN rails TH35 according to EN 60715. The bus is connected using a bus connecting terminal; a data rail is not necessary.

KNX software functions: Roller shutter functions: Running time. Idle time. Differentiated disable functions and weather alarms. 8-bit positioning for height. Scenes. Manual/automatic function. Differentiated status and status feedback functions.

For each roller shutter output:

Nominal voltage: AC 100-240 V $\pm 10\%$

Operating voltage: min. AC 90 V - max. AC 265 V

Mains frequency: 50-60 Hz $\pm 10\%$

Nominal current: 10 A, inductive load $\cos\phi = 0.6$

Motor load: AC 100 V, max. 434 W

AC 230 V, max. 1000 W

AC 240 V, max. 1043 W

Device width: 4 modules = approx. 72 mm

Contents: With bus connecting terminal and cable cover.

Blind actuators



Blind actuator REG-K/4x/10 with manual mode



Version	Art. no.
light grey	MTN649804

For independent control of 4 blind/roller shutter drives. The functions of the blind channels is freely configurable. All blind outputs can be operated manually using push-button operation. Channel status display via LEDs. A green LED indicates readiness for operation. With integrated bus coupler. For installation on DIN rails TH35 according to EN 60715. The bus is connected using a bus connecting terminal; a data rail is not necessary.
KNX software functions: Blind functions: Blind type. Running time. Idle time. Step interval. Differentiated disable functions and weather alarms. 8-bit positioning for height and slat. Scenes. Manual/automatic mode. Differentiated status and status feedback functions.

For each blind output:
Nominal voltage: AC 100-240 V $\pm 10\%$
Operating voltage: min. AC 90 V - max. AC 265 V
Mains frequency: 50-60 Hz $\pm 10\%$
Nominal current: 10 A, inductive load $\cos\phi = 0.6$
Motor load: AC 100 V, max. 434 W
 AC 230 V, max. 1000 W
 AC 240 V, max. 1043 W
Device width: 4 modules = approx. 72 mm
Contents: With bus connecting terminal and cable cover.

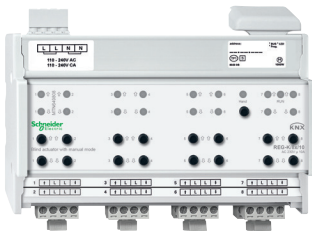

Blind actuator REG-K/8x/10 with manual mode



Version	Art. no.
light grey	MTN649808

For independent control of 8 blind/roller shutter drives. The functions of the blind channels is freely configurable. All blind outputs can be operated manually using push-buttons. Channel status display via LEDs. A green LED indicates readiness for operation. With integrated bus coupler. For installation on DIN rails TH35 according to EN 60715. The bus is connected using a bus connecting terminal; a data rail is not necessary.
KNX software functions: Blind functions: Blind type. Running time. Idle time. Step interval. Differentiated disable functions and weather alarms. 8-bit positioning for height and slat. Scenes. Manual/automatic mode. Differentiated status and status feedback functions.

For each blind output:
Nominal voltage: AC 230 V, 50 - 60 Hz
Nominal current: 10 A, $\cos\phi = 0.6$
Motor load: AC 230 V, max. 1000 W
External auxiliary voltage (optional): AC 110-240 V, 50-60 Hz, max. 2 VA
Device width: 8 modules = approx. 144 mm
Contents: With bus connecting terminal and cable cover.

Blind actuators

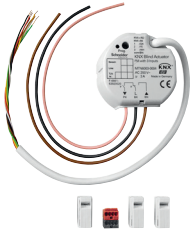

KNX blind actuator FM with 3 inputs



Version

Art. no.

MTN6003-0004

1-gang blind actuator with three inputs for installation in a size 60 switch box. Floating contacts can be connected to the three inputs.

The inputs have already been assigned to the actuator at the factory, enabling operation without programming.

Connection to 230 V via a flexible cable, approx. 20 cm long. The inputs and the KNX are connected via a 6-core, approx. 30 cm long, connecting cable. The connecting cable for the inputs can be extended to a max. of 5 m.

KNX software functions: Blind actuator function:

Operation mode: Blinds, roller shutters, awnings or ventilation flaps. Raising or lowering times with extension for the upper limit position. Status feedback of the position or of the slat position. Active/passive status feedback, cycl. status feedback function. Up to 5 safety functions (3 wind alarms, 1 rain alarm, 1 frost alarm). Cycl. monitoring. Sun protection function with fixed and variable positions. Shading controls with heating/cooling automatic mode and presence function. Behaviour when bus voltage fails/recovers. Status feedback delay after bus voltage recovery. Priority function. 8 Scene function. Memory function for scenes.

Input function:

Free assignment of the switching, dimming, blind and valuator functions. Locking object.

Behaviour when bus voltage recovers.

Switching: two switch objects per input. Command on rising/falling edge (ON, OFF, TOGGLE, no reaction).

Dimming: Single surface and dual-surface operation. Time between dimming and switching and dim step values. Telegram repetition and send stop telegram.

Blinds: Command on rising edge (none, UP, DOWN, TOGGLE). Operation concept (Step - Move - Step or Move - Step). Time between short and long operation. Slat adjustment time.

Valuator and Scene ext. input: Edge (push-button as make contact, push-button as break contact, switch) and value on edge. Value adjustment via long push-button action for valuator. Scene ext. unit with memory function.

Nominal voltage: AC 230 V, 50/60 Hz

Switching current: 3 A, AC1

Nominal output

Motor: AC 230 V, 600 VA

Inputs: 3

Temperature range: -5 °C to 45 °C

Type of protection: IP 20

Dimensions: 53x53x28 (WxHxD)

Note: For installation in a double box or an electronic box (Kaiser). There must be a minimum gap of 4mm between the 230V connection and the connection for the KNX/Inputs (SELV)

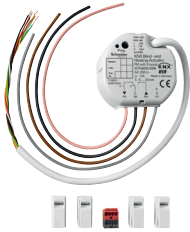

KNX blind and heating actuator with 3 inputs



Version

Art. no.

MTN6003-0006

1-gang blind actuator and 1-gang heating actuator with three inputs for installation in a size 60 switch box. Floating contacts can be connected to the inputs.

The inputs have already been assigned to the actuator at the factory, enabling operation without programming.

Connection to 230 V via a flexible cable, approx. 20 cm long. The inputs and the KNX are connected via a 6-core, approx. 30 cm long, connecting cable. The connecting cable for the inputs can be extended to a max. of 5 m.

KNX software functions: Blind actuator function:

Operation mode: Blinds, roller shutters, awnings or ventilation flaps. Raising or lowering times with extension for the upper limit position. Status feedback of the position or of the slat position. Active/passive status feedback, cycl. status feedback function. Up to 5 safety functions (3 wind alarms, 1 rain alarm, 1 frost alarm). Cycl. monitoring. Sun protection function with fixed and variable positions. Shading controls with heating/cooling automatic mode and presence function. Behaviour when bus voltage fails/recovers. Status feedback delay after bus voltage recovery. Priority function. 8 Scene function. Memory function for scenes.

Heating actuator function:

Can be controlled by a control value (1 bit or 1 byte). Status indication (1 bit or 1 byte). Valve control (de-energised open/closed). Summer or winter mode can be selected. Cyclical monitoring of control value. Emergency mode and alarm signal. Priority control (forced setting for summer and winter mode with different values). Behaviour when bus voltage recovers and fails. Overload or short circuit signal. Control of the valve drives (switching or via PWM). Function to protect valves from sticking.

Input function:

Free assignment of the switching, dimming, blind and valuator functions. Locking object.

Behaviour when bus voltage recovers.

Switching: two switch objects per input. Command on rising/falling edge (ON, OFF, TOGGLE, no reaction).

Dimming: Single surface and dual-surface operation. Time between dimming and switching and dim step values. Telegram repetition and send stop telegram.

Blinds: Command on rising edge (none, UP, DOWN, TOGGLE), Operation concept (Step - Move - Step or Move - Step). Time between short and long operation. Slat adjustment time.

Valuator and Scene ext. input: Edge (push-button as make contact, push-button as break contact, switch) and value on edge. Value adjustment via long push-button action for valuator.

Scene ext. unit with memory function.

Nominal voltage: AC 230 V, 50/60 Hz

Blind output

Switching current: 3 A, AC1

Nominal output

Motor: AC 230 V, 600 VA

Heating output

Switch contact: Triac

Nominal current: 5 to 25 mA, max. 2 valve drives

Inputs: 3



Temperature range: -5 °C to 45 °C

Type of protection: IP 20

Dimensions: 53x53x28 (WxHxD)





















Note: For installation in a double box or an electronic box (Kaiser). There must be a minimum gap of 4mm between the 230V connection and the connection for the KNX/Inputs (SELV)

Functions overview dimming actuators

	KNX univers. dimming actuator LL REG-K/2x230/300 W	KNX univers. dimming actuator LL REG-K/4x230/250 W	
			
Article number	MTN6710-0002	MTN6710-0004	
Number of channels	2	4	
Device width	4 modules	8 modules	
Manual operation push-buttons	■	■	
Connecting terminal (consumer load)	Plug-in screw terminals	Plug-in screw terminals	
Nominal voltage	AC 110 - 130 V AC 220 - 230 V 50/60 Hz	AC 110 - 130 V AC 220 - 230 V 50/60 Hz	
Halogen load at 230 V			
<ul style="list-style-type: none"> ■ Configuration of 4 channels ■ Configuration of 3 channels ■ Configuration of 2 channels ■ Configuration of 1 channel 	— — 2x300 W/VA (230V), 2x150 W/VA (110V) 1x400 W/VA (230V), 1x200 W/VA (110V)	4 x 250 W/VA 1 x 350 W/VA, 2 x 250 W/VA 2x350 W/VA (230V) 1x350 W/VA (230V)	
Minimum resistive load	4 W	4 W	
Minimum resistive-inductive load	25 VA	25 VA	
Minimum resistive-capacitive load	4 W	4 W	
Automatic load detection / leading edge (RL-LED, ESL, CFL)	■ / ■	■ / ■	
Connection of different Phases	■	■	
Relay for load separation	■	■	
Input for extension unit operation, lockable (switching, staircase lighting function)	—	—	
Software			
Manual operation enable/disable via bus	■	■	
Dimming function			
<ul style="list-style-type: none"> ■ Minimum dimming value / Maximum dimming value ■ Starting behaviour / Memory function / 50% brightness (ESL/CFL) ■ Dimming object switches channel ■ Value object switches channel ■ Same dimming time at central function and scenes ■ Delay times for ON and OFF ■ Base dimming curve with 3 thresholds ■ Dimming time reduction via object ■ 4 preconfigured dimming sets for the dimming time reduction* 	■ / ■ ■ / ■ / ■ ■ ■ ■ ■ ■ ■ ■ ■	■ / ■ ■ / ■ / ■ ■ ■ ■ ■ ■ ■ ■ ■	
Staircase lighting function with/without manual OFF	■	■	
<ul style="list-style-type: none"> ■ Retriggerable ■ Not retriggerable ■ Time addable ■ Prewarn 	■ ■ ■ ■	■ ■ ■ ■	
Scenes (1 byte)	8	8	
Central function	■	■	
Higher priority function	■ Disable function ■ Logic operation or priority function	■ Disable function ■ Logic operation or priority function	
Logic operation			
<ul style="list-style-type: none"> ■ AND, OR ■ Switch object has an inverted impact to the logic operation 	■ ■	■ ■	
Disable function			
<ul style="list-style-type: none"> ■ Behaviour of locking after bus voltage recovery ■ Behavior at the start/end of the locking 	■ ■	■ ■	
Behaviour of main voltage recovery / bus voltage recovery / download / bus voltage failure	■ / ■ / ■ / —	■ / ■ / ■ / —	
Status messages			
<ul style="list-style-type: none"> ■ Switch ■ Brightness value ■ Error 	■ ■ ■	■ ■ ■	

4 switchable speed sets with 6 values. This corresponds to 24 storable dimming speeds for: Switch on, switch off staircase timer, dim, values, scenes, higher priority functions.

Functions overview dimming actuators

Universal dimming actuator REG-K/4x230/150 W	Universal dimming actuator REG-K/230/500 W	Universal dimming actuator REG-K/230/1000 W
 MTN649315	 MTN649350	 MTN649310
4	1	1
6 modules	4 modules	4 modules
■	■	■
Plug-in screw terminals	Plug-in screw terminals	Plug-in screw terminals
AC 220-230 V, 50/60 Hz	AC 220-230 V, 50/60 Hz	AC 110-230 V, 50/60 Hz; 0.22-4.3 A 110 V, 50 Hz: 24-480 VA 230V, 50 Hz: 50-1000 VA 110 V, 60 Hz: 24-400 VA 230V, 60 Hz: 50-850 VA
4 x 150 W/VA 1x300 W/VA, 2x150 W/VA 2x300 W/VA 1x300 W/VA	— — — 1x500 W/VA	— — — 1x1000 W/VA
25 W	25 W	25 W
50 VA	50 VA	50 VA
50 VA	50 VA	50 VA
■ / —	■ / —	■ / —
—	—	—
—	—	—
AC 230 V, 50/60 Hz, for mechanical push-buttons	AC 230 V, 50/60 Hz, for mechanical push-buttons	AC 110-230 V, 50/60 Hz, for mechanical push-buttons
■	■	■
		
		
8	8	8
		
		
		
— / ■ / ■ / —	— / ■ / ■ / —	— / ■ / ■ / —
		

Dimming actuators



KNX universal dimming actuator LL REG-K/2x230/300 W

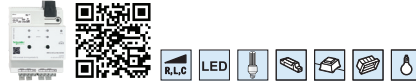

Version	Art. no.
light grey	MTN6710-0002

LED/ESL/CFL dimmer

For switching and dimming **dimmable LED lamps**, incandescent lamps, HV halogen lamps, LV halogen lamps using dimmable wound transformers or electronic transformers or dimmable compact fluorescent lamps.

(leading and trailing-edge phases)

With integral bus coupler, screw terminals, short-circuit, open circuit and excess temperature protection with soft start lamp start.

Different phases can be connected.

The dimmer actuator automatically recognises the connected load. This happens in the background when switching on. Combinations of ohmic and inductive, or ohmic and capacitive loads can also be connected. Combinations of inductive and capacitive loads must not be connected. No flickering of LEDs in switched-off state.

For installation on DIN rails TH35 according to EN 60715. The bus is connected using a bus connecting terminal.

KNX software functions: Dimming operation by KNX, dimming and emergency operation by manual switch, enable/block manual mode by bus, automatic dimming operating mode or leading edge phase for certain LED/ESL/CFL lamps, load separation possible in OFF state, various dimming curves and dimming rates, same dimming time, minimum/maximum dimming value, starting behaviour, memory function, 50% brightness when starting ESL/CFL lamp, dimming/value object switches channel, ON/OFF delay, staircase lighting function (with/without manual OFF function, non-/retriggerable, time accumulating, warning function), scenes (up to 8 internally stored brightness values can be retrieved), central function, logic operations (AND/OR) or priority control, disable function (behaviour of locking), status feedback (switching state, brightness value, fault), behaviour on mains voltage recovery/bus voltage recovery/download.

Nominal voltage: AC 110 - 130 V / AC 220 - 230 V, 50/60 Hz

Channels: 2 (different phases possible)

Nominal power: 2 x 300 W/VA (230 V), 2 x 150 W/VA (110 V)

1 channel: 1 x 400 W/VA (230 V), 1 x 200 W/VA (110 V)

Minimum load/channel: 4 W (ohmic)

4 W (ohmic-capacitive)

25 VA (ohmic-inductive)

Device width: 4 HP = approx. 72 mm

Note: Information about the "Dimming LED lamps" can be obtained on the Internet at "Schneider-Electric dimmer test". <http://schneider-electric.dimmer-test.com>

Contents: With bus connecting terminal and cable cover.

Dimming actuators/control units



KNX universal dimming actuator LL REG-K/4x230/250 W



Version	Art. no.
light grey	MTN6710-0004

LED/ESL/CFL dimmer
 For switching and dimming **dimnable LED lamps**, incandescent lamps, HV halogen lamps, LV halogen lamps using dimmable wound transformers or electronic transformers or dimmable compact fluorescent lamps.
(leading and trailing-edge phases)
 With integral bus coupler, screw terminals, short-circuit, open circuit and excess temperature protection with soft start lamp start.
 Different phases can be connected.
 The dimmer actuator automatically recognises the connected load. This happens in the background when switching on. Combinations of ohmic and inductive, or ohmic and capacitive loads can also be connected. Combinations of inductive and capacitive loads must not be connected. No flickering of LEDs in switched-off state.
 For installation on DIN rails TH35 according to EN 60715. The bus is connected using a bus connecting terminal.
KNX software functions: Dimming operation by KNX, dimming and emergency operation by manual switch, enable/block manual mode by bus, automatic dimming operating mode or leading edge phase for certain LED/ESL/CFL lamps, load separation possible in OFF state, various dimming curves and dimming rates, same dimming time, minimum/maximum dimming value, starting behaviour, memory function, 50% brightness when starting ESL/CFL lamp, dimming/value object switches channel, ON/OFF delay, staircase lighting function (with/without manual OFF function, non-/retriggerable, time accumulating, warning function), scenes (up to 8 internally stored brightness values can be retrieved), central function, logic operations (AND/OR) or priority control, disable function (behaviour of locking), status feedback (switching state, brightness value, fault), behaviour on mains voltage recovery/bus voltage recovery/download.
Nominal voltage: AC 110 - 130 V / AC 220 - 230 V, 50/60 Hz
Channels: 4 (different phases possible)
Nominal power: 4 x 250 W/VA (230 V), 4 x 125 W/VA (110 V)
 3 channels: 1 x 350 W/VA and 2 x 250 W/VA (230 V), 1 x 175 W/VA and 2 x 125 W/VA (110 V)
 2 channels: 2 x 350 W/VA (230 V), 2 x 175 W/VA (110 V)
Minimum load/channel: 4 W (ohmic)
 4 W (ohmic-capacitive)
 25 VA (ohmic-inductive)
Device width: 8 HP = approx. 144 mm
Note: Information about the "Dimming LED lamps" can be obtained on the Internet at "Schneider-Electric dimmer test". <http://schneider-electric.dimmer-test.com>
Contents: With bus connecting terminal and cable cover.

Dimming actuators/control units



Universal dimming actuator REG-K/4x230/150 W



Version	Art. no.
light grey	MTN649315

AC 230 V, 50-60 Hz
 For switching and dimming incandescent lamps, HV halogen lamps and LV halogen lamps using dimmable wound transformers or electronic transformers.
(Phase control and phase alignment)
 With integral bus coupler, screw terminals, short-circuit, open-circuit and excess temperature protection with soft start function.
 The dimming actuator automatically recognises the connected load. Combinations of ohmic and inductive, or ohmic and capacitive loads can also be connected. Combinations of inductive and capacitive loads must not be connected.
 For installation on DIN rails TH35 according to EN 60715. The bus is connected using a bus connecting terminal; a data rail is not necessary.
KNX software functions: Dimming operation via KNX, extension units and on the device, different dimming curves and dimming speeds, the same dimming time, memory function, ON/OFF delay, staircase time function with/without manual OFF function, scenes (up to eight stored brightness values can be retrieved), central function, logic operation or priority control, blocking function, status feedback.
Nominal voltage: AC 220 - 230 V, 50/60 Hz
Nominal power/channel: max. 150 W/VA
 25 W minimum load (ohmic)
 50 VA minimum load (ohmic/inductive/capacitive)
Input (extension unit operation): AC 230 V, 50/60 Hz (same phase as the dimming channels)
Device width: 6 modules = approx. 105 mm
Extension unit operation: Extension TELE insert MTN573998
Contents: With bus connecting terminal and cable cover.



Universal dimming actuator REG-K/230/500 W



Version	Art. no.
light grey	MTN649350

AC 230 V, 50-60 Hz
 For switching and dimming incandescent lamps, HV halogen lamps and LV halogen lamps using dimmable wound transformers or electronic transformers.
(Phase control and phase alignment)
 With integral bus coupler, screw terminals, short-circuit, open-circuit and excess temperature protection with soft start function.
 The dimming actuator automatically recognises the connected load. Combinations of ohmic and inductive, or ohmic and capacitive loads can also be connected. Combinations of inductive and capacitive loads must not be connected.
 For installation on DIN rails TH35 according to EN 60715. The bus is connected using a bus connecting terminal; a data rail is not necessary.
KNX software functions: Dimming operation via KNX, extension units and on the device, different dimming curves and dimming speeds, the same dimming time, memory function, ON/OFF delay, staircase time function with/without manual OFF function, scenes (up to eight stored brightness values can be retrieved), central function, logic operation or priority control, blocking function, status feedback.
Nominal voltage: AC 220 - 230 V, 50/60 Hz
Nominal power/channel: max. 500 W/VA
 25 W minimum load (ohmic)
 50 VA minimum load (ohmic/inductive/capacitive)
Input (extension unit operation): AC 230 V, 50/60 Hz (same phase as the dimming channel)
Device width: 4 modules = approx. 72 mm
Extension unit operation: Extension TELE insert MTN573998
Contents: With bus connecting terminal and cable cover.

Dimming actuators/control units



Universal dimming actuator REG-K/230/1000 W



Version	Art. no.
light grey	MTN649310

AC 230 V, 50-60 Hz

For switching and dimming incandescent lamps, HV halogen lamps and LV halogen lamps using dimmable wound transformers or electronic transformers.

(Phase control and phase alignment)

With integral bus coupler, screw terminals, short-circuit, open-circuit and excess temperature protection with soft start function.

The dimming actuator automatically recognises the connected load. Combinations of ohmic and inductive, or ohmic and capacitive loads can also be connected. Combinations of inductive and capacitive loads must not be connected.

For installation on DIN rails TH35 according to EN 60715. The bus is connected using a bus connecting terminal; a data rail is not necessary.

KNX software functions: Dimming operation via KNX, extension units and on the device, different dimming curves and dimming speeds, the same dimming time, memory function, ON/OFF delay, staircase time function with/without manual OFF function, scenes (up to eight stored brightness values can be retrieved), central function, logic operation or priority control, blocking function, status feedback.

Nominal voltage: AC 110-230 V ±10%

Operating voltage: min. AC 92 V - max. AC 253 V

Mains frequency: 50/60 Hz ±2%

Nominal load

Ohmic loads: AC 110 V /50 Hz, 14-480 W

AC 230 V /50 Hz, 30-1000 W

AC 110 V /60 Hz, 14-400 W

AC 230 V /60 Hz, 30-850 W

Inductive/capacitive loads: AC 110 V /50 Hz, 24-480 VA

AC 230 V /50 Hz, 50-1000 VA

AC 110 V /60 Hz, 24-400 VA

AC 230 V /60 Hz, 50-850 VA

Input (extension unit operation): AC 110-230 V, 50/60 Hz (same phase as the dimming channel)

Device width: 4 modules = approx. 72 mm

Extension unit operation: Extension TELE insert MTN573998

Contents: With bus connecting terminal and cable cover.

Dimming actuators/control units



KNX universal dimming actuator FM 50-210 W/VA with 2 inputs



Version	Art. no.
---------	----------

MTN6003-0003

1-gang universal dimming actuator with two inputs for installation in a size 60 switch box. Floating contacts can be connected to the two inputs. The inputs have already been assigned to the actuator at the factory, enabling operation without programming. Connection to 230 V via a flexible cable, approx. 20 cm long. The inputs and the KNX are connected via a 6-core, approx. 30 cm long, connecting cable. The connecting cable for the inputs can be extended to a max. of 5 m.

KNX software functions: Dimming actuator function:
 Switching and dimming lamps. Switch on and dimming behaviour can be adjusted. Feedback of the switching state and the brightness value. "Soft ON", "Soft OFF" and time dimmer. Dimming or jumping to brightness values. Time-delayed switch off when a switch off brightness is not reached. Short circuit and load failure signal. Scene operation. Blocked operation via an object with parameterisable brightness value at the beginning and the end of blocking. Behaviour of the dimming actuator after bus voltage recovery.

Input function:
 Free assignment of the switching, dimming, blind and valuator functions. Locking object. Behaviour when bus voltage recovers. Switching: two switch objects per input. Command on rising/falling edge (ON, OFF, TOGGLE, no reaction). Dimming: Single surface and dual-surface operation. Time between dimming and switching and dim step values. Telegram repetition and send stop telegram. Blinds: Command on rising edge (none, UP, DOWN, TOGGLE), Operation concept (Step - Move - Step or Move - Step). Time between short and long operation. Slat adjustment time. Valuator and Scene ext. input: Edge (push-button as make contact, push-button as break contact, switch) and value on edge. Value adjustment via long push-button action for valuator. Scene ext. unit with memory function.

Nominal voltage: AC 230 V, 50/60 Hz
Connected load
Ohmic load: AC 230 V, 50 to 210 W
Incandescent lamps: AC 230 V, 50 to 210 W
Halogen lamps: AC 230 V, 50 to 210 W
LV halogen lamps: 50 to 210 W/VA, wound transformer
 50 to 210 W, electronic transformers
Inputs: 2
Type of protection: IP 20
Dimensions: 53x53x28 (WxHxD)
Note: For installation in a double box or an electronic box (Kaiser). There must be a minimum gap of 4mm between the 230V connection and the connection for the KNX/Inputs (SELV)

Control units 1-10 V



Control unit 0-10 V REG-K/1-gang with manual mode



Version	Art. no.
light grey	MTN647091

For connecting devices with 0-10 V interface to KNX. With integrated bus coupler and screw terminals (230 V) or plug-in screw terminals (0-10 V). Each individual 230 V switch output can be operated manually with a manual switch.

For installation on DIN rails TH35 according to EN 60715. The bus is connected using a bus connecting terminal; a data rail is not necessary.

KNX software functions: Different dimming curves and dimming speeds, the same dimming time, memory function, ON/OFF delay, staircase time function with/without manual OFF function, scenes (up to eight stored brightness values can be retrieved), central function, logic operation or priority control, blocking function, status feedback, behaviour on bus voltage recovery.

Switch contact: for switching the electronic ballasts/transformers

Nominal voltage: AC 100-240 V $\pm 10\%$

Operating voltage: min. AC 90 V - max. AC 265 V

Mains frequency: 50-60 Hz $\pm 10\%$

Nominal current: 16 A, inductive load $\cos\phi = 0.6$

Nominal load

Incandescent lamps: AC 100 V, max. 1600 W

AC 230 V, max. 3600 W

AC 240 V, max. 3840 W

Halogen lamps: AC 100 V, max. 1086 W

AC 230 V, max. 2500 W

AC 240 V, max. 2608 W

Fluorescent lamps: AC 100 V, max. 1086 VA

AC 230 V, max. 2500 VA

AC 240 V, max. 2608 VA

parallel-compensated

Capacitive load: AC 100 V, max. 1600 W, 200 μF

AC 230 V, max. 3600 W, 200 μF

AC 240 V, max. 3840 W, 200 μF

0-10 V interface: 0.12-100 mA

Voltage range: DC 0-10 V

Device width: 2.5 HP = approx. 45 mm

Contents: With bus connecting terminal and cable cover.

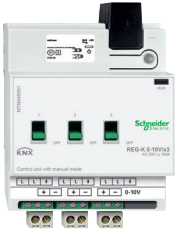

Control unit 0-10 V REG-K/3-gang with manual mode



Version	Art. no.
light grey	MTN646991

For connecting devices with 0-10 V interface to KNX. With integrated bus coupler and screw terminals (230 V) or plug-in screw terminals (0-10 V). Each individual 230 V switch output can be operated manually with a manual switch.

For installation on DIN rails TH35 according to EN 60715. The bus is connected using a bus connecting terminal; a data rail is not necessary.

KNX software functions: Different dimming curves and dimming speeds, the same dimming time, memory function, ON/OFF delay, staircase time function with/without manual OFF function, scenes (up to eight stored brightness values can be retrieved), central function, logic operation or priority control, blocking function, status feedback, behaviour on bus voltage recovery.

Switch contact: for switching the electronic ballasts/transformers

Nominal voltage: AC 230 V, 50-60 Hz

Nominal current: 16 A, $\cos\varphi = 0.6$

Switching capacity: AC 230 V, 3600 W, $\cos\varphi = 1$

Capacitive load: AC 230 V, 16 A, 200 μF

Incandescent lamps: AC 230 V, max. 3600 W

Halogen lamps: AC 230 V, max. 2500 W

Fluorescent lamps:

AC 230 V, max. 3600 VA, uncompensated

AC 230 V, max. 2500 VA, with parallel compensation

LV- halogen lamps with wound transformer: max. 2000 VA

0-10 V interface: 0.12-100 mA

Voltage range: DC 0-10 V

Device width: 4 HP = ca. 72 mm

Contents: With bus connecting terminal and cable cover.

DALI gateways

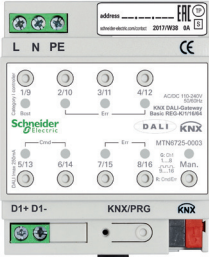

KNX DALI Gateway Basic REG-K/1/16/64



Version	Art. no.
	MTN6725-0003 New

The KNX DALI Gateway connects the KNX bus to 1 DALI output. The gateway is a category I DALI control device with an integrated DALI power supply for the ECGs. The device is a Single-Master Controller according to EN 62386 ed/1 and ed/2. It is able to control DALI ECGs ed/1 and ed/2 -also mixed- but according to single-master controller it cannot support DALI-2 sensors like movement- and presence detectors, switches etc. It supports the switching and dimming of up to 64 ECGs in 16 groups and the control of more than 16 scenes.

Different colour commands (e.g. white tone control, RGB, XY and HSV) can be interpreted by KNX push-buttons, for example, and DALI DT8 lights can be activated accordingly.

The operating hours meter logs the operating hours for the groups. Error messages from individual ECGs and groups can be transmitted via the KNX and visualised.

A colour control module allows up to 16 time switch functions for brightness and colour on a weekly basis, provided that the device is connected to a time update system. The up to 16 time programmes with up to 300 commands per DALI output can be enabled or disabled using KNX objects. DALI commissioning and configuration, group allocation and scene set-up can be carried out using the ETS application and an ETS app (DCA).

With integrated bus coupler. For installation on DIN rails TH35 according to EN 60715. The bus is connected using a bus connecting terminal; a data rail is not necessary.

KNX software functions: Switching, dimming, value and colour objects per group, plus switching, value and colour objects for broadcast control. Staircase timer function with dimmed lights, also for advance warning and normal, continuous, night and panic modes. Differentiated error analysis per EB and group. Scenes with brightness and colour. Energy saving thanks to reduction in EB standby losses due to additional KNX switching actuator. The colour control module can be used to control brightnesses and colours based on a weekly time switch.

(Requirement: weekday and time synchronisation) Any time interval possible, up to 90 s.

The up to 16 time programmes can be controlled using KNX objects. Operating hours can be recorded and reset by group, and transmitted by group as an alarm if a threshold value is exceeded. The firmware can be updated using an FAT32-formatted Micro-SD card.

Supply voltage: AC/DC 100-240 V, 50/60 Hz

Outputs: 1x DALI D+, D-, DC 16-18 V (basic insulation, not SELV), max. 250 mA, short circuit-proof

Interfaces: KNX, DALI

Type: DALI category I control device (single master)

Wire range: Mains supply or DALI: 1.5 - 2.5 mm²

IP protection rating: IP20

Housing width: 4 HP = approx. 69 mm

Contents: With bus connecting terminal.

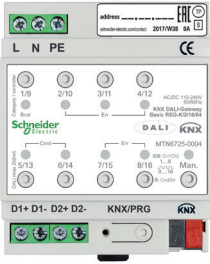

KNX DALI Gateway Basic REG-K/2/16/64



Version	Art. no.
	MTN6725-0004 New

The KNX DALI Gateway connects the KNX bus to **2 DALI outputs**. The gateway is a category I DALI control device with an integrated DALI power supply for the ECGs. The device is a Single-Master Controller according to EN 62386 ed/1 and ed/2. It is able to control DALI ECGs ed/1 and ed/2 -also mixed- but according to single-master controller it cannot support DALI-2 sensors like movement- and presence detectors, switches etc. For each DALI output, it supports the switching and dimming of up to 64 ECGs in 16 groups and the control of more than 16 scenes.

Different colour commands (e.g. white tone control, RGB, XY and HSV) can be interpreted by KNX push-buttons, for example, and DALI DT8 lights can be activated accordingly.

The operating hours meter logs the operating hours for the groups. Error messages from individual ECGs and groups can be transmitted via the KNX and visualised.

A colour control module allows up to 16 time switch functions for brightness and colour on a weekly basis, provided that the device is connected to a time update system. The up to 16 time programmes with up to 300 commands per DALI output can be enabled or disabled using KNX objects. DALI commissioning and configuration, group allocation and scene set-up can be carried out using the ETS application and an ETS app (DCA).

With integrated bus coupler. For installation on DIN rails TH35 according to EN 60715. The bus is connected using a bus connecting terminal; a data rail is not necessary.

KNX software functions: Switching, dimming, value and colour objects per group, plus switching, value and colour objects for broadcast control. Staircase timer function with dimmed lights, also for advance warning and normal, continuous, night and panic modes. Differentiated error analysis per EB and group. Scenes with brightness and colour. Energy saving thanks to reduction in EB standby losses due to additional KNX switching actuator. The colour control module can be used to control brightnesses and colours based on a weekly time switch. (Requirement: weekday and time synchronisation) Any time interval possible, up to 90 s.

The up to 16 time programmes can be controlled using KNX objects. Operating hours can be recorded and reset by group, and transmitted by group as an alarm if a threshold value is exceeded. The firmware can be updated using an FAT32-formatted Micro-SD card.

Supply voltage: AC/DC 100-240 V, 50/60 Hz

Outputs: 2x DALI D+, D-, DC 16-18 V (basic insulation, not SELV), max. 250 mA, short circuit-proof

Interfaces: KNX, DALI

Type: DALI category I control device (single master)

Wire range: Mains supply or DALI: 1.5 - 2.5 mm²

IP protection rating: IP20

Housing width: 4 HP = approx. 69 mm



KNX DALI gateway REG-K/1/16(64)/64/IP1



Version

Art. no.

MTN6725-0001

The KNX DALI gateway connects KNX to the DALI bus. The gateway is a category I control device with an integrated DALI power supply for the ECGs (electronic ballasts / electronic control gear). The device is a Single-Master Controller according to EN 62386 ed/1 and ed/2. It is able to control DALI ECGs ed/1 and ed/2 -also mixed- but according to single-master controller it cannot support DALI-2 sensors like movement- and presence detectors, switches etc. It supports the switching and dimming of up to 64 ECGs in 16 groups and the control up to 16 scenes. The 64 ECGs can be controlled individually or in groups. Error messages of individual ECGs or each connected lamp can be transmitted to the KNX and visualised.

DALI commissioning and configuration, as well as group assignment and scene setting, can be carried out using:

- the device (display and operating buttons which can be optionally disabled)
- the integrated Web server

Web server functions:

Access via the LAN network using a PC, PDA or web panel. Commissioning is also made easier using a WLAN adapter. The internal web pages can be used to start up the device, and to configure, operate and display all important functions.

- Two separate user profiles with their own password
- Effect module with 16 effects and a total of up to 500 commands
- Configuring: scenes, effects, service, maintenance, burn-in, operating hours
- Operating: device, ECGs and groups
- Displays: Status and error messages

New improvements with version 0D: (available 2016)

- DT8-Colour control on the DALI side, up to 16 colour templates with up to 300 commands basing on a weekly timer
- DALI-scenes with brightness and colour values
- Tunable white control to improve the environment for human beings. Colour control i.e. product presentation
- Possibility to avoid the password protection or lock the Admin role for the web server access

Remark: The colour control can be used with devices (from version 0B) after a software upgrade. For details discover the new application description.

With integrated bus coupler. For installation on DIN rails TH35 according to EN 60715. The bus is connected using a bus connecting terminal; a data rail is not necessary.

KNX software functions: Switching, dimming and value object per group or EB. Staircase timer function, status objects, delays between status feedbacks. Detailed error messages per EB and group. Test of DALI ECGs for emergency lighting with central battery or built-in battery with selectable test intervals. Parallel broadcast triggering of all ECGs, switch-on/switch-off. Dimming speeds for relative dimming and dimming values. Dimming value max./min. Various modes (normal, permanent, night, panic). Operating hours counter and automatic burn-in per EB.

Supply voltage: AC/DC 100-240 V, 50/60 Hz

Outputs: DALI D+, D-, DC 16-18 V (basic insulation, not SELV), max. 128 mA, short circuit-proof

Interfaces: KNX, Ethernet RJ-45, DALI

Type: Category I control device (single master)

Wire range: Supply or DALI: 1.5-2.5 mm²

Type of protection: IP 20

Device width: 4 modules = approx. 72 mm

Contents: With bus connecting terminal.

Other actuators

■ The devices have protection type IP 20 and can only be used indoors. Devices with a different type of protection are labelled separately.



Analogue actuator REG-K/4-gang



Version	Art. no.
light grey	MTN682291

The output channels can be parameterised for different current and voltage signals to control different analogue variables (e.g. servomotors). The actuator has four analogue outputs. For use in connection with the analogue actuator module REG/4-gang, 8 analogue outputs are provided. Connections are made using the sub-bus.

With continuity checking of the current outputs.
For installation on DIN rails TH35 according to EN 60715. The bus is connected using a bus connecting terminal; a data rail is not necessary.

Auxiliary voltage: AC 24 V (+/-10 %)

Analogue outputs: 4

Current signals: 0 ... 20 mA, 4 ... 20 mA

Voltage signals: 0 ... 1 V, 0.. 10 V

Continuity checking: 4 ... 20 mA

Outputs: DC 24 V, 100 mA (total)

Device width: 4 modules = approx. 72 mm

In KNX, to be completed with: Power supply REG, AC 24 V/1 A MTN663529

Contents: With bus connecting terminal and cable cover.

Room temperature control unit System M

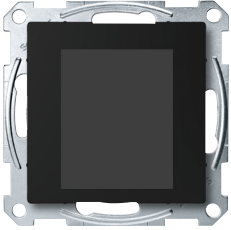

KNX Multitouch Pro



Version

Art. no.

MTN6215-0310

New

For System M.

Comfortable room controller for controlling up to 32 room functions and the room temperature. All functions are displayed on a touch screen and are called up using simple finger movements. The user chooses from 3 interface designs that can be freely assigned to the room functions. The room temperature control can be shown in 2 different designs.

With room temperature control unit, display and connection for the remote sensor.

The room temperature control unit can be used for heating and cooling with infinitely adjustable KNX valve drives or to trigger switch actuators and heating actuators.

ETS device functions:

- Switch-on behaviour of the user interface
- Proximity function: The display and the start screen only become visible when approached
- Gesture function: The device recognises a gesture (horizontal or vertical swipe movement) and triggers a function. In this way, the light can be switched on when you enter the room, for example.
- Cleaning mode: For a specific period of time, neither touches nor gestures are detected
- Adjusting the background lighting
- Setting the screen saver

With integrated bus coupler. The bus is connected using a bus connecting terminal.

KNX software functions:**Control unit/push-button:**

Switching, toggling, dimming (single/dual-surface), blind (single/dual-surface), pulse edges trigger 1-, 2-, 4- or 8-bit telegrams, pulse edges with 2-byte telegrams, 8-bit linear regulator, scene retrieval, scene saving, signal function, fan control, operating modes, setpoint adjustment

Functions of the room temperature control unit:

Controller type: 2-step controller, continuous-action PI control, switching PI control (PWM)

Output: continuous in the range 0 to 100% or switching ON/OFF

Controller mode:

- Heating with one controller output
- Cooling with one controller output
- Heating and cooling with separate controller outputs
- 2-step heating with 2 control outputs
- 2-step cooling with 2 control outputs
- 2-step heating and cooling with 4 control outputs

Operating modes: Comfort, comfort extension, standby (ECO), night reduction, frost/heat protection

Move all setpoints. Save all setpoint temperatures and operating modes when reset. External temperature monitoring. Additional output of the control value as 1 byte value on the PWM.

Signal function for the actual temperature, valve protection function.

Scene function.

Operation: Touch display

Accessories: Dismantling protection MTN6270-0000

Remote sensor for universal room temperature control unit with touch display MTN5775-0003

Note: Programmable with ETS4 and higher.

Contents: With bus connecting terminal and supporting plate.



Push-button 2-gang plus with room temperature control unit



Version	Art. no.
<input checked="" type="checkbox"/> white, glossy	MTN6212-0344
<input type="checkbox"/> polar white, glossy	MTN6212-0319
<input type="checkbox"/> active white, glossy	MTN6212-0325
<input checked="" type="checkbox"/> anthracite	MTN6212-0414
<input type="checkbox"/> aluminium	MTN6212-0460

For System M.

Convenient control unit with 4 operating buttons, operating and status display and labelling field. The operating display can also be used as an orientation light.

With room temperature control unit and display.

With 5 red LEDs.

The room temperature control unit can be used for heating and cooling with infinitely adjustable KNX valve drives or to trigger switch actuators and heating actuators. With the white backlit display for showing e.g. the time, date, temperature and operating mode. Menu for setting default operating modes, setpoint value, working/non-working day (external trigger), display mode, time, switching times and brightness of the display.

The push-buttons are freely parameterisable as push-button pairs (dual-surface) or as single push-buttons.

With integrated bus coupler. The bus is connected using a bus connecting terminal.

KNX software functions:

Functions of the push-buttons:

Switching, toggling, dimming, blind control (relative or absolute), pulse edges trigger 1-, 2-, 4- or 8-bit telegrams (distinction between short and long operation), pulse edges with 2-byte telegrams (distinction between short and long operation), 8-bit linear regulator, scene retrieval, scene saving, disable functions, timed control with synchronisation, notification functions, the cyclic reading of external temperature values, fan control, operating modes, move setpoints.

Functions of the room temperature control unit:

Controller type: 2-step control, continuous PI controller, switching PI controller (PWM)

Output: continuous in the range 0 to 100% or switching ON/OFF

Controller mode:

- Heating with one controller output
- Cooling with one controller output
- Heating and cooling with separate controller outputs
- Heating and cooling with one controller output
- 2-step heating with 2 control outputs
- 2-step cooling with 2 control outputs
- 2-step heating and cooling with 4 control outputs

Operating modes: Comfort, comfort extension, standby, night reduction, frost/heat protection

Move all setpoints, save all setpoint temperatures and operating modes when reset, external temperature monitoring, additional output of the control value as 1 byte value on the PWM.

Monitoring function for the actual temperature, valve protection function.

Scene function.

Operation: Menu.

Contents: With bus connecting terminal and supporting plate.

Screw for protection against dismantling.

With protective hood for plaster.



Push-button 4-gang plus with room temperature control unit



Version	Art. no.
<input checked="" type="checkbox"/> white, glossy	MTN6214-0344
<input type="checkbox"/> polar white, glossy	MTN6214-0319
<input type="checkbox"/> active white, glossy	MTN6214-0325
<input checked="" type="checkbox"/> anthracite	MTN6214-0414
<input type="checkbox"/> aluminium	MTN6214-0460

For System M.

Convenient control unit with 8 operating buttons, operating and status display and labelling field. The operating display can also be used as an orientation light.

With room temperature control unit and display.

With integrated piezoelectric buzzer to display alarm states and IR receiver. All functions of the respective buttons can be controlled via IR remote control.

With 9 red LEDs.

The room temperature control unit can be used for heating and cooling with infinitely adjustable KNX valve drives or to trigger switch actuators and heating actuators. With the white backlit display for showing e.g. the time, date, temperature and operating mode. Menu for setting default operating modes, setpoint value, working/non-working day (external trigger), display mode, time, switching times and brightness of the display.

The push-buttons are freely parameterisable as push-button pairs (dual-surface) or as single push-buttons.

With integrated bus coupler. The bus is connected using a bus connecting terminal.

KNX software functions:

Functions of the push-buttons:

Switching, toggling, dimming, blind control (relative or absolute), pulse edges trigger 1-, 2-, 4- or 8-bit telegrams (distinction between short and long operation), pulse edges with 2-byte telegrams (distinction between short and long operation), 8-bit linear regulator, scene retrieval, scene saving, disable functions, timed control with synchronisation, notification functions, the cyclic reading of external temperature values, fan control, operating modes, move setpoints.

Functions of the room temperature control unit:

Controller type: 2-step control, continuous PI controller, switching PI controller (PWM)

Output: continuous in the range 0 to 100% or switching ON/OFF

Controller mode:

- Heating with one controller output
- Cooling with one controller output
- Heating and cooling with separate controller outputs
- Heating and cooling with one controller output
- 2-step heating with 2 control outputs
- 2-step cooling with 2 control outputs
- 2-step heating and cooling with 4 control outputs

Operating modes: Comfort, comfort extension, standby, night reduction, frost/heat protection

Move all setpoints, save all setpoint temperatures and operating modes when reset, external temperature monitoring, additional output of the control value as 1 byte value on the PWM.

Monitoring function for the actual temperature, valve protection function.

Scene function.

Operation: Menu.

Transmitter: IR universal remote control MTN5761-0000

To be completed with: M-Smart frame, 2-gang without central bridge piece MTN4788.., M-Arc frame, 2-gang without central bridge piece MTN4858.., M-Star frame, 2-gang without central bridge piece MTN4668.., MTN4768.., MTN4868.., M-Plan frames, 2-gang without central bridge piece MTN4888.., MTN5158.., Metal frame, 2-gang without central bridge piece M-Elegance MTN4038.., Real glass frame, 2-gang without central bridge piece M-Elegance MTN4048..

Contents: With bus connecting terminal and supporting plate.

Screw for protection against dismantling.

With protective hood for plaster.

Room temperature control units



Room temperature control unit with display



Version	Art. no.
<input checked="" type="checkbox"/> white, glossy	MTN6241-0344
<input type="checkbox"/> polar white, glossy	MTN6241-0319
<input type="checkbox"/> active white, glossy	MTN6241-0325
<input checked="" type="checkbox"/> anthracite	MTN6241-0414
<input type="checkbox"/> aluminium	MTN6241-0460

For System M.

KNX Room temperature control unit with display, labelling field, operation and status LED. The 4 buttons allow to shift set values and change operation modes.

With 5 red LEDs.

The room temperature control unit can be used for heating and cooling with infinitely adjustable KNX valve drives or to trigger switch actuators and heating actuators. With the white backlit display for showing e.g. the time, date, temperature and operating mode. Menu for setting default operating modes, setpoint value, working/non-working day (external trigger), display mode, time, switching times and brightness of the display.

With integrated bus coupler. The bus is connected using a bus connecting terminal.

KNX software functions:

Functions of the room temperature control unit:

Controller type: 2-step control, continuous PI controller, switching PI controller (PWM)

Output: continuous in the range 0 to 100% or switching ON/OFF

Controller mode:

- Heating with one controller output
- Cooling with one controller output
- Heating and cooling with separate controller outputs
- Heating and cooling with one controller output
- 2-step heating with 2 control outputs
- 2-step cooling with 2 control outputs
- 2-step heating and cooling with 4 control outputs

Operating modes: Comfort, comfort extension, standby, night reduction, frost/heat protection

Move all setpoints, save all setpoint temperatures and operating modes when reset, external temperature monitoring, additional output of the control value as 1 byte value on the PWM.

Monitoring function for the actual temperature, valve protection function.

Functions of the push-buttons:

Selection of 1- 4 operating modes each push-button. Move setpoint.

Accessories: Protective hood for plaster System M MTN627591

Contents: With bus connecting terminal and supporting plate.

Screw for protection against dismantling.

With protective hood for plaster.

Room temperature control units



KNX Room temperature control unit, flush-mounted/PI with 4-gang push-button interface



Version	Art. no.
<input checked="" type="checkbox"/> white, glossy	MTN616744
<input type="checkbox"/> polar white, glossy	MTN616719
<input type="checkbox"/> active white, glossy	MTN616725
<input checked="" type="checkbox"/> anthracite	MTN616814
<input checked="" type="checkbox"/> aluminium	MTN616860

For System M.

The device is a room temperature control unit and a binary input. Depending on the operating mode, the current temperature setpoint value and the room temperature, a control value for the heating or cooling control unit is transmitted to the KNX. The temperature can either be recorded by the internal or the external temperature sensor which must be connected to the push-button interface.

The push-button interface generates an internal signal voltage for connecting max. four conventional push-buttons or floating contacts. Of these, two inputs can be used to connect low current LEDs.

With integrated bus coupler. The bus is connected using a bus connecting terminal.

KNX software functions:

Functions of the room temperature control unit:

Controller type: 2-step control, continuous PI control, switching PI control (PWM)

Output: continuous in the range 0 to 100% or switching ON/OFF

Controller mode:

- Heating with one controller output
- Cooling with one controller output
- Heating and cooling with separate controller outputs
- Heating and cooling with one controller output
- 2-step heating with 2 control outputs
- 2-step cooling with 2 control outputs

Operating modes: comfort, comfort extension, standby, night economy, frost/heat protection

Operation: Setpoint adjustment can be parameterised in the range with adjusting wheel; presence push-button functions can be parameterised/switched off

Valve protection, controller disable

Push-button interface functions:

Switching, dimming, external blinds, valuator (dimming valuator, extension unit for light scenes with/without memory function, temperature valuator, brightness valuator).

Push-button interface: up to 4 inputs, 2 of which can be used as outputs and one for connecting the remote sensor.

Output voltage: 5 V (SELV)

Output current: max. 0.8 mA

Max. cable length: Inputs/outputs max. 5 m, remote sensor max. 50 m

Accessories: Remote sensor for room temperature control unit UP/PI MTN616790



Remote sensor for room temperature control unit UP/PI



Version	Art. no.
black	MTN616790

Temperature sensor the floor/room temperature measurement

Cable length: 4 m (2 x 0.75 mm²)

To be completed with: KNX Room temperature control unit, flush-mounted/PI with 4-gang push-button interface

System M MTN6167..., MTN6168..

Room temperature control units



Room temperature control unit for properties



Version	Art. no.
<input checked="" type="checkbox"/> white, glossy	MTN6221-0344
<input type="checkbox"/> polar white, glossy	MTN6221-0319
<input type="checkbox"/> active white, glossy	MTN6221-0325
<input checked="" type="checkbox"/> anthracite	MTN6221-0414
<input type="checkbox"/> aluminium	MTN6221-0460

For System M.

KNX room temperature control unit for properties with integrated bus coupler. Depending on the operating mode, the current temperature setpoint value and the actual room temperature, a control value for the heating or cooling control unit is transmitted to the KNX. The temperature can optionally be measured by the internal or by an external bus temperature sensor. The room temperature control unit can be used for heating and cooling with infinitely adjustable KNX valve drives or to trigger switch actuators and heating actuators. Operating mode, nominal value, control function settings made only via the bus. The device does not have any operating and display elements.

With integrated bus coupler. The bus is connected using a bus connecting terminal.

KNX software functions:

Functions of the room temperature control unit:

Controller type: 2-step control, continuous PI controller, switching PI controller (PWM)

Output: continuous in the range 0 to 100% or switching ON/OFF

Controller mode:

- Heating with one controller output
- Cooling with one controller output
- Heating and cooling with separate controller outputs
- Heating and cooling with one controller output
- 2-step heating with 2 control outputs
- 2-step cooling with 2 control outputs
- 2-step heating and cooling with 4 control outputs

Operating modes: Comfort, comfort extension, standby, night reduction, frost/heat protection

Move all setpoints, save all setpoint temperatures and operating modes when reset, external temperature monitoring, additional output of the control value as 1 byte value on the PWM.

Monitoring function for the actual temperature, valve protection function.

Operation: only via bus telegrams.

Contents: With bus connecting terminal and supporting plate.

With protective hood for plaster.

Room temperature control unit System Design



KNX Multitouch Pro



Version

Art. no.

MTN6215-5910

New

For System Design.

Comfortable room controller for controlling up to 32 room functions and the room temperature. All functions are displayed on a touch screen and are called up using simple finger movements. The user chooses from 3 interface designs that can be freely assigned to the room functions. The room temperature control can be shown in 2 different designs.

With room temperature control unit, display and connection for the remote sensor.

The room temperature control unit can be used for heating and cooling with infinitely adjustable KNX valve drives or to trigger switch actuators and heating actuators.

ETS device functions:

- Switch-on behaviour of the user interface
- Proximity function: The display and the start screen only become visible when approached
- Gesture function: The device recognises a gesture (horizontal or vertical swipe movement) and triggers a function. In this way, the light can be switched on when you enter the room, for example.
- Cleaning mode: For a specific period of time, neither touches nor gestures are detected
- Adjusting the background lighting
- Setting the screen saver

With integrated bus coupler. The bus is connected using a bus connecting terminal.

KNX software functions:**Control unit/push-button:**

Switching, toggling, dimming (single/dual-surface), blind (single/dual-surface), pulse edges trigger 1-, 2-, 4- or 8-bit telegrams, pulse edges with 2-byte telegrams, 8-bit linear regulator, scene retrieval, scene saving, signal function, fan control, operating modes, setpoint adjustment

Functions of the room temperature control unit:

Controller type: 2-step controller, continuous-action PI control, switching PI control (PWM)

Output: continuous in the range 0 to 100% or switching ON/OFF

Controller mode:

- Heating with one controller output
- Cooling with one controller output
- Heating and cooling with separate controller outputs
- 2-step heating with 2 control outputs
- 2-step cooling with 2 control outputs
- 2-step heating and cooling with 4 control outputs

Operating modes: Comfort, comfort extension, standby (ECO), night reduction, frost/heat protection

Move all setpoints. Save all setpoint temperatures and operating modes when reset. External temperature monitoring. Additional output of the control value as 1 byte value on the PWM.

Signal function for the actual temperature, valve protection function.

Scene function.

Operation: Touch display

Accessories: Dismantling protection MTN6270-0000

Remote sensor for universal room temperature control unit with touch display MTN5775-0003

Fixing frame for 3-module box MTN6270-0015

D-Life frame, 1-gang, for 3-module box MTN6010-65xx

Note: Programmable with ETS4 and higher.

Contents: With bus connecting terminal and supporting plate.

Room temperature control units



Remote sensor for room temperature control unit UP/PI



Version	Art. no.
black	MTN616790



Temperature sensor for the floor/room temperature measurement
Cable length: 4 m (2 x 0.75 mm²)
To be completed with: KNX Room temperature control unit, flush-mounted/PI with 4-gang push-button interface
 System M MTN6167..., MTN6168..

Room temperature control unit Altira



KNX Room temperature control unit with display



Version	Art. no.	
 white	ALB45154	Discontinued
 aluminium	ALB46154	Discontinued

2 modules
 In Altira design.
 KNX Room temperature control unit with display and 4 buttons. 2 buttons allow to shift set values and change operation modes, the other 2 buttons are used for navigation in the menu. The room temperature control unit can be used for heating and cooling with infinitely adjustable KNX valve drives or to trigger switch actuators and heating actuators. With the white backlit display for showing e.g. the time, date, temperature and operating mode. Menu for setting default operating modes, setpoint value, working/non-working day (external trigger), display mode, time, switching times and brightness of the display.
 With integrated bus coupler. The bus is connected using a bus connecting terminal.

KNX software functions:

Functions of the room temperature control unit:

Controller type: 2-step control, continuous PI controller, switching PI controller (PWM)

Output: continuous in the range 0 to 100% or switching ON/OFF

Controller mode:

- Heating with one controller output
- Cooling with one controller output
- Heating and cooling with separate controller outputs
- Heating and cooling with one controller output
- 2-step heating with 2 control outputs
- 2-step cooling with 2 control outputs
- 2-step heating and cooling with 4 control outputs

Operating modes: Comfort, comfort extension, standby, night reduction, frost/heat protection

Move all setpoints, save all setpoint temperatures and operating modes when reset, external temperature monitoring, additional output of the control value as 1 byte value on the PWM.

Monitoring function for the actual temperature, valve protection function.

Functions of the push-buttons:

Selection of 1- 4 operating modes each push-button. Move setpoint.

Contents: With bus connecting terminal.

Room temperature control unit Unica



KNX Room temperature control unit with display



Version	Art. no.
<input type="checkbox"/> white	MGU3.534.18
<input type="checkbox"/> ivory	MGU3.534.25

2 modules

In Unica design.

KNX Room temperature control unit with display and 4 buttons. 2 buttons allow to shift set values and change operation modes, the other 2 buttons are used for navigation in the menu. The room temperature control unit can be used for heating and cooling with infinitely adjustable KNX valve drives or to trigger switch actuators and heating actuators. With the white backlit display for showing e.g. the time, date, temperature and operating mode. Menu for setting default operating modes, setpoint value, working/non-working day (external trigger), display mode, time, switching times and brightness of the display.

With integrated bus coupler. The bus is connected using a bus connecting terminal.

KNX software functions:

Functions of the room temperature control unit:

Controller type: 2-step control, continuous PI controller, switching PI controller (PWM)

Output: continuous in the range 0 to 100% or switching ON/OFF

Controller mode:

- Heating with one controller output
- Cooling with one controller output
- Heating and cooling with separate controller outputs
- Heating and cooling with one controller output
- 2-step heating with 2 control outputs
- 2-step cooling with 2 control outputs
- 2-step heating and cooling with 4 control outputs

Operating modes: Comfort, comfort extension, standby, night reduction, frost/heat protection

Move all setpoints, save all setpoint temperatures and operating modes when reset, external temperature monitoring, additional output of the control value as 1 byte value on the PWM.

Monitoring function for the actual temperature, valve protection function.

Functions of the push-buttons:

Selection of 1- 4 operating modes each push-button. Move setpoint.

Contents: With bus connecting terminal.

Room temperature control unit Unica Top



KNX Room temperature control unit with display



Version	Art. no.
■ aluminium	MGU3.534.30
■ graphite	MGU3.534.12

2 modules

In Unica Top design.

KNX Room temperature control unit with display and 4 buttons. 2 buttons allow to shift set values and change operation modes, the other 2 buttons are used for navigation in the menu. The room temperature control unit can be used for heating and cooling with infinitely adjustable KNX valve drives or to trigger switch actuators and heating actuators. With the white backlit display for showing e.g. the time, date, temperature and operating mode. Menu for setting default operating modes, setpoint value, working/non-working day (external trigger), display mode, time, switching times and brightness of the display.

With integrated bus coupler. The bus is connected using a bus connecting terminal.

KNX software functions:

Functions of the room temperature control unit:

Controller type: 2-step control, continuous PI controller, switching PI controller (PWM)

Output: continuous in the range 0 to 100% or switching ON/OFF

Controller mode:

- Heating with one controller output
- Cooling with one controller output
- Heating and cooling with separate controller outputs
- Heating and cooling with one controller output
- 2-step heating with 2 control outputs
- 2-step cooling with 2 control outputs
- 2-step heating and cooling with 4 control outputs

Operating modes: Comfort, comfort extension, standby, night reduction, frost/heat protection

Move all setpoints, save all setpoint temperatures and operating modes when reset, external temperature monitoring, additional output of the control value as 1 byte value on the PWM.

Monitoring function for the actual temperature, valve protection function.

Functions of the push-buttons:

Selection of 1- 4 operating modes each push-button. Move setpoint.

Contents: With bus connecting terminal.

Devices for individual room temperature control



KNX valve drive with status LED and 2 inputs



Version	Art. no.
	MTN6921-0001

EMO valve drive for heating valves. The device has 2 inputs for window contacts or presence detectors for instance.

Valve lift display via red LEDs. With automatic valve lift detection. The valve drive can be connected directly to the KNX. A separate power supply is not required. With integrated bus coupler.

Power consumption: max. 10 mA

Lift: max. 7,5 mm

Positioning force: 120 N

Type of protection: IP 21

Protection class: III as per EN 60730

Installation: Snaps onto the valve adapter

Dimensions: (H x Wx D) 82 x 50 x 65 mm

Contents: With 2 valve adapters (VA10/VA78).

Note: New Version (B) is available in Halogen and PVC free cable and housing.

KNX fan coil actuator REG-K



Version	Art. no.
light grey	MTN645094

For heating, ventilation and air conditioning control. For controlling fan convectors with up to three speeds, as well as for controlling three-step motor drives (continuous/pulse-width-modulated) or two-step thermal drives. The actuator supports 2-pipe and 4-pipe systems.

Two floating binary inputs for window contact and level contact for condensed water container, for example. Connection of 1-speed to 3-speed fans. The push-button plus with room temperature control can be used to activate the fan coil actuator.

With integrated bus coupler. For installation on DIN rails TH35 according to EN 60715. The bus is connected using a bus connecting terminal; a data rail is not necessary.

KNX software functions: Fan control:

In automatic mode, the fan speeds are controlled dependently by the control value of the push-button plus. The three fan speeds and automatic mode can be switched via EIB telegram. The fan can be controlled either directly or via actuators / suitable dimming actuators. Fan speed feedback is possible via corresponding status feedback objects e.g. status LED of the push-button. The fan speed as well as the automatic status "Auto" can be displayed on the display of the push-button plus with TCU.

Valve control:

Type of controller: PI controller (PWM and continuous).

Controller mode: Heating and/or cooling with common or separate valve outputs.

Operating modes: The operating mode is selected in the push-button plus with TCU.

Power supply: AC 230 V ±10 %, 50/60 Hz

Power consumption: max. 3 VA

Outputs: 3 floating contacts (fan coil), 2 semi-conductor switches (valve connections)

Switching capacity for valves: 0.5 A, AC 24V - 230 V

Additional relay switching capacity: 16 A

Fan relay switching capacity: 8 A

Inputs: 2, max. cable length 5 m

Operation: Key for fan levels and heating/cooling mode

Displays: 9 status LEDs

Device width: 4 modules = approx. 72 mm

Accessories: Thermoelectric valve drive 230 V MTN639125, Thermoelectric valve drive 24 V MTN639126, Push-button 2-gang plus with room temperature control unit System M MTN6212-03.. /-04.., Push-button 4-gang plus with room temperature control unit System M MTN6214-03.. /-04..

Room temperature control units



Heating actuator REG-K/6x24/230/0.16A



Version	Art. no.
	MTN6730-0001

For actuation of thermoelectric valve drives for heating or cooling ceilings. The heating actuator has 6 electronic outputs. Up to 4 valve drives can be connected to each output. The outputs are either switch activated (1 bit) or PWM signal (1 byte) activated. Each output is overload-protected and short-circuit-protected.

All outputs can be operated manually using push-button operation. Building site operation is possible.

For installation on DIN rails TH35 according to EN 60715. The bus is connected using a bus connecting terminal.

KNX software functions: Characteristics of valve drive (de-energised open/closed), PWM cycle time per channel, valve protection function per channel, cyclical monitoring of the control value per channel, operating hours counter, status indication per channel (nominal value, short circuit, overload, valve protection active, service mode, manual operation active, priority control active), summer and winter mode, locking each output in a forced position, behaviour on bus voltage failure and recovery, mains failure signal, group feedback, transmission of the largest 1 byte variable value.

Nominal voltage: AC 110-230 V, 50/60 Hz

Outputs: 6, electronic AC 24 V / 230 V

Nominal current: 0.05 ... 0.16 A, ohmic

Switch-on current: max. 1.5 A (2 s)

Minimum load per used output: 1 valve drive

Number of valve drives: max. 4 per output (230 V drives)
max. 2 per output (24 V drives)

Device width: 4 modules = approx. 72 mm

Accessories: Thermoelectric valve drive 230 V MTN639125

Thermoelectric valve drive 24 V MTN639126

Contents: With bus connecting terminal and cable cover.

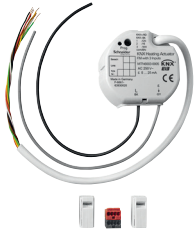

KNX heating actuator FM with 3 inputs

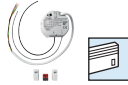

Version

Art. no.

MTN6003-0005

1-gang heating actuator with three inputs for installation in a size 60 switch box. Floating contacts can be connected to the inputs.

Connection to 230 V via a flexible cable, approx. 20 cm long. The inputs and the KNX are connected via a 6-core, approx. 30 cm long, connecting cable. The connecting cable for the inputs can be extended to a max. of 5 m.

KNX software functions: Heating actuator function:

Can be controlled by a control value (1 bit or 1 byte). Status indication (1 bit or 1 byte). Valve control (de-energised open/closed). Summer or winter mode can be selected. Cyclical monitoring of control value. Emergency mode and alarm signal. Priority control (forced setting for summer and winter mode with different values). Behaviour when bus voltage recovers and fails. Overload or short circuit signal. Control of the valve drives (switching or via PWM). Function to protect valves from sticking.

Input function:

Free assignment of the switching, dimming, blind and valuator functions. Locking object.

Behaviour when bus voltage recovers.

Switching: two switch objects per input. Command on rising/falling edge (ON, OFF, TOGGLE, no reaction).

Dimming: Single surface and dual-surface operation. Time between dimming and switching and dim step values. Telegram repetition and send stop telegram.

Blinds: Command on rising edge (none, UP, DOWN, TOGGLE), Operation concept (Step - Move - Step or Move - Step). Time between short and long operation. Slat adjustment time.

Valuator and Scene ext. input: Edge (push-button as make contact, push-button as break contact, switch) and value on edge. Value adjustment via long push-button action for valuator.

Scene ext. unit with memory function.

Nominal voltage: AC 230 V, 50/60 Hz

Switch contact: Triac

Nominal current: 5 to 25 mA, max. 2 valve drives

Inputs: 3

Temperature range: -5 °C to 45 °C

Type of protection: IP 20

Dimensions: 53x53x28 (WxHxD)

Note: For installation in a double box or an electronic box (Kaiser). There must be a minimum gap of 4mm between the 230V connection and the connection for the KNX/Inputs (SELV)

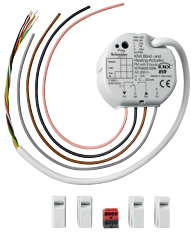

KNX blind and heating actuator with 3 inputs



Version

Art. no.

MTN6003-0006

1-gang blind actuator and 1-gang heating actuator with three inputs for installation in a size 60 switch box. Floating contacts can be connected to the inputs.

The inputs have already been assigned to the actuator at the factory, enabling operation without programming.

Connection to 230 V via a flexible cable, approx. 20 cm long. The inputs and the KNX are connected via a 6-core, approx. 30 cm long, connecting cable. The connecting cable for the inputs can be extended to a max. of 5 m.

KNX software functions: Blind actuator function:

Operation mode: Blinds, roller shutters, awnings or ventilation flaps. Raising or lowering times with extension for the upper limit position. Status feedback of the position or of the slat position. Active/passive status feedback, cycl. status feedback function. Up to 5 safety functions (3 wind alarms, 1 rain alarm, 1 frost alarm). Cycl. monitoring. Sun protection function with fixed and variable positions. Shading controls with heating/cooling automatic mode and presence function. Behaviour when bus voltage fails/recovers. Status feedback delay after bus voltage recovery. Priority function. 8 Scene function. Memory function for scenes.

Heating actuator function:

Can be controlled by a control value (1 bit or 1 byte). Status indication (1 bit or 1 byte). Valve control (de-energised open/closed). Summer or winter mode can be selected. Cyclical monitoring of control value. Emergency mode and alarm signal. Priority control (forced setting for summer and winter mode with different values). Behaviour when bus voltage recovers and fails. Overload or short circuit signal. Control of the valve drives (switching or via PWM). Function to protect valves from sticking.

Input function:

Free assignment of the switching, dimming, blind and valuator functions. Locking object.

Behaviour when bus voltage recovers.

Switching: two switch objects per input. Command on rising/falling edge (ON, OFF, TOGGLE, no reaction).

Dimming: Single surface and dual-surface operation. Time between dimming and switching and dim step values. Telegram repetition and send stop telegram.

Blinds: Command on rising edge (none, UP, DOWN, TOGGLE), Operation concept (Step - Move - Step or Move - Step). Time between short and long operation. Slat adjustment time.

Valuator and Scene ext. input: Edge (push-button as make contact, push-button as break contact, switch) and value on edge. Value adjustment via long push-button action for valuator. Scene ext. unit with memory function.

Nominal voltage: AC 230 V, 50/60 Hz

Blind output

Switching current: 3 A, AC1

Nominal output

Motor: AC 230 V, 600 VA

Heating output

Switch contact: Triac

Nominal current: 5 to 25 mA, max. 2 valve drives

Inputs: 3

Temperature range: -5 °C to 45 °C

Type of protection: IP 20

Dimensions: 53x53x28 (WxHxD)

Note: For installation in a double box or an electronic box (Kaiser). There must be a minimum gap of 4mm between the 230V connection and the connection for the KNX/Inputs (SELV)

Room temperature control units



Thermoelectric valve drive 230 V



Version	Art. no.
polar white	MTN639125

Thermoelectric valve drive for opening and closing valves. For 2-step or PWM control of heating, air conditioning and ventilation systems, individual room control of surface heaters, control of heating circuit distributors, radiators, convector heaters, cooling ceilings. Operation is carried out by the heating actuator REG-K/6x24/230/0.16A, fan coil actuator REG-K or a room temperature control unit (230 V) with 2-step or PWM output. Valve adapters permit compatibility with a variety of valve bodies and heating circuit distributors.

- First-open function: The drive is factory-set to de-energised open. This allows the heating to be operated during the building shell phase.
- De-energised closed
- Functional display (open, closed, intermediate settings)
- Adjustment control
- Plug-in connecting cable
- Plug-in assembly

Supply voltage: AC 230 V, 50/60 Hz

Starting current: max. 350 mA for max. 100 ms

Power consumption: 1 W

Lift: approx. 4 mm

Running time: 3.5 min for 4 mm

Positioning force: 100 N ± 5 %

Circulating medium temperature: 0-100°C

Type of protection: IP 54 / II, in all installation positions

Connecting cable: 1 m, 2x0.75 mm² pluggable

Dimensions: 59.2x44.3x56 mm (HxWxD)

To be completed with: Room temperature control insert with switch MTN536302/04

In KNX, to be completed with: Heating actuator REG-K/6x24/230/0.16A MTN6730-0001

KNX fan coil actuator REG-K MTN645094

KNX heating actuator FM with 3 inputs MTN6003-0005

KNX blind and heating actuator with 3 inputs MTN6003-0006

Accessories: Valve adapter VA50 for thermoelectric valve drive MTN639150

Valve adapter VA78 for thermoelectric valve drive MTN639178

Valve adapter VA80 for thermoelectric valve drive MTN639180

Room temperature control units



Thermoelectric valve drive 24 V



Version	Art. no.
polar white	MTN639126

Thermoelectric valve drive for opening and closing valves. For 2-step or PWM control of heating, air conditioning and ventilation systems, individual room control of surface heaters, control of heating circuit distributors, radiators, convector heaters, cooling ceilings. Operation is carried out by the heating actuator REG-K/6x24/230/0.16A, fan coil controller REG-K or a room temperature control unit (24 V) with 2-step or PWM output. Valve adapters permit compatibility with a variety of valve bodies and heating circuit distributors.

- First-open function: The drive is factory-set to de-energised open. This allows the heating to be operated during the building shell phase.
- De-energised closed
- Functional display (open, closed, intermediate settings)
- Adjustment control
- Plug-in connecting cable
- Plug-in assembly

Supply voltage: AC/DC 24 V +20%/-10%, 0-60 Hz

Starting current: < 300 mA for max. 2 min

Power consumption: 1 W

Lift: approx. 4 mm

Running time: 3.5 min for 4 mm

Positioning force: 100 N ± 5%

Medium temperature: 0-100°C

Type of protection/protection class: IP 54 / II, in all installation positions

Connecting cable: 1 m, 2x0.75 mm² pluggable

Dimensions: 59.2 x 44.3 x 56 mm (HxWxD)

To be completed with: Room temperature control insert with switch MTN536302/04

Power supply REG, AC 24 V/1 A MTN663529

In KNX, to be completed with: Heating actuator REG-K/6x24/230/0.16A MTN6730-0001

KNX fan coil actuator REG-K MTN645094

Power supply REG, AC 24 V/1 A MTN663529

Accessories: Valve adapter VA50 for thermoelectric valve drive MTN639150

Valve adapter VA78 for thermoelectric valve drive MTN639178

Valve adapter VA80 for thermoelectric valve drive MTN639180



Valve adapter VA50 for thermoelectric valve drive



Version	Art. no.
	MTN639150

For Honeywell+Braukmann, Reich, Landis+Gyr, MNG, Cazzagniga. Valve adapters permit compatibility with a variety of valve bodies and heating circuit distributors

To be completed with: Thermoelectric valve drive 230 V MTN639125, Thermoelectric valve drive 24 V MTN639126

Valve adapter VA78 for thermoelectric valve drive



Version	Art. no.
	MTN639178

For Danfoss RA. Valve adapters permit compatibility with a variety of valve bodies and heating circuit distributors

To be completed with: Thermoelectric valve drive 230 V MTN639125, Thermoelectric valve drive 24 V MTN639126



Valve adapter VA80 for thermoelectric valve drive



Version	Art. no.
	MTN639180

For Heimeier, Herb, Onda, Schlösser (from 1993), Oventrop M30x1.5, TeSa. Valve adapters permit compatibility with a variety of valve bodies and heating circuit distributors

To be completed with: Thermoelectric valve drive 230 V MTN639125, Thermoelectric valve drive 24 V MTN639126

Power supplies



Power supply REG, 24 V DC / 0.4 A



Version	Art. no.
light grey	MTN693003

Power supply for 24 V binary inputs.
 For installation onto DIN rails EN 50022.
 With integrated overload and short-circuit protection.
 For installation on DIN rails TH35 according to EN 60715.

Primary supply: AC 230 V, 48-63 Hz

Output voltage: DC 24 V +/- 3 %

Output current: max. 0.4 A

Output power: max. 10 W

Device width: 1 module = approx. 18 mm

For supplying power to: Binary input REG-K/4x24 MTN644892, Binary input REG-K/8x24 MTN644792, KNX/IP router REG-K MTN680329

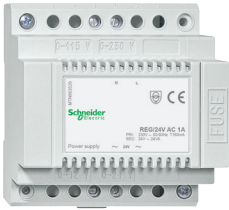

Power supply REG, AC 24 V/1 A



Version	Art. no.
light grey	MTN663529

Power supply for 24 V binary inputs, weather station REG-K/4-gang, analogue input module REG-K/4-gang, rain sensor, wind sensor with 0 - 10 V interface and heating, KNX/IP router REG-K.

With fuse.

For installation on DIN rails TH35 according to EN 60715.

Primary supply: AC 230 V, +/- 10 %, 50-60 Hz

Output voltage: AC 24 V

Output current: max. 1 A

Fuse: 5x20 mm, 250 V, T 160 mA

Device width: 5 modules = approx. 90 mm

For supplying power to: Binary input REG-K/8x24 MTN644792, Weather station REG-K/4-gang MTN682991, Rain sensor MTN663595, Wind sensor with 0-10 V interface and heating MTN663592, KNX/IP router REG-K MTN680329, Thermoelectric valve drive 24 V MTN639126

Contents: With spare fuse.

ALB45150	75	MTN6180-6050	70	MTN6270-5007	51	MTN616744	161	MTN625860	68
ALB45151	75	MTN6180-6051	70	MTN6270-5008	52	MTN616790		MTN627514	62
ALB45152	75	MTN6180-6052	70	MTN6270-5009	52		161, 164	MTN627560	62
ALB45153	93	MTN6181-6035	71	MTN6300-0001	100	MTN616814	161	MTN627591	64
ALB45154	164	MTN6212-0319	65,	MTN6300-0002	100	MTN616860	161	MTN627614	62
ALB46150	75		158	MTN6302-6033	92	MTN617119	62	MTN627660	62
ALB46151	75	MTN6212-0325	65,	MTN6302-6034	92	MTN617125	62	MTN627814	63
ALB46152	75		158	MTN6302-6035	92	MTN617144	62	MTN627860	63
ALB46153	93	MTN6212-0344	65,	MTN6302-6036	92	MTN617219	62	MTN627914	63
ALB46154	164		158	MTN6302-6050	92	MTN617225	62	MTN627960	63
CCT15860	111	MTN6212-0414	65,	MTN6302-6051	92	MTN617244	62	MTN629993	118
CCT15861	111		158	MTN6302-6052	92	MTN617419	63	MTN630419	103
LSS100100	37	MTN6212-0460	65,	MTN6303-0019	99	MTN617425	63	MTN630425	103
LSS100200	39		158	MTN6304-0019	95	MTN617444	63	MTN630444	103
LSS900100	25	MTN6214-0319	66,	MTN6305-0019	96	MTN617519	63	MTN630614	103
MGU3.530.12	78		159	MTN6354-0019	97	MTN617525	63	MTN630660	103
MGU3.530.18	77	MTN6214-0325	66,	MTN6355-0019	98	MTN617544	63	MTN630719	101
MGU3.530.25	77		159	MTN6500-0113	54	MTN618319	63	MTN630760	101
MGU3.530.30	78	MTN6214-0344	66,	MTN6501-0001	44	MTN618320	63	MTN630819	101
MGU3.531.12	78		159	MTN6501-0002	45	MTN618419	63	MTN630860	101
MGU3.531.18	77	MTN6214-0414	66,	MTN6503-0201	34	MTN618420	63	MTN630919	102
MGU3.531.25	77		159	MTN6600-0603	33	MTN619119	67	MTN630960	102
MGU3.531.30	78	MTN6214-0460	66,	MTN6606-0008	110	MTN619125	67	MTN631619	91
MGU3.532.12	78		159	MTN6606-0070	111	MTN619144	67	MTN631625	91
MGU3.532.18	77	MTN6215-0310	55,	MTN6606-0071	110	MTN619219	68	MTN631644	91
MGU3.532.25	77		61, 157	MTN6700-0002	121	MTN619225	68	MTN631719	91
MGU3.532.30	78	MTN6215-5910	56,	MTN6700-0004	124	MTN619244	68	MTN631725	91
MGU3.533.12	94		72, 163	MTN6700-0008	128	MTN619319	67	MTN631744	91
MGU3.533.18	93	MTN6216-5910	57,	MTN6700-0012	131	MTN619325	67	MTN632515	90
MGU3.533.25	93		73	MTN6710-0002	146	MTN619344	67	MTN632519	90
MGU3.533.30	94	MTN6221-0319	162	MTN6710-0004	147	MTN619419	67	MTN632569	90
MGU3.534.12	166	MTN6221-0325	162	MTN6725-0001	155	MTN619425	67	MTN632614	91
MGU3.534.18	165	MTN6221-0344	162	MTN6725-0003	153	MTN619444	67	MTN632660	91
MGU3.534.25	165	MTN6221-0414	162	MTN6725-0004	154	MTN619519	68	MTN632714	91
MGU3.534.30	166	MTN6221-0460	162	MTN6730-0001	168	MTN619525	68	MTN632760	91
MTN5761-0000	31	MTN6241-0319	160	MTN6903-6014	58	MTN619544	68	MTN639125	171
MTN5775-0003	57,	MTN6241-0325	160	MTN6903-6019	58	MTN619619	68	MTN639126	172
	61, 73	MTN6241-0344	160	MTN6903-6060	58	MTN619625	68	MTN639150	172
MTN6003-0001	119	MTN6241-0414	160	MTN6903-6114	59	MTN619644	68	MTN639178	172
MTN6003-0002	120	MTN6241-0460	160	MTN6903-6119	59	MTN619719	68	MTN639180	172
MTN6003-0003	150	MTN6260-0307	48	MTN6903-6160	59	MTN619725	68	MTN639190	90
MTN6003-0004	141	MTN6260-0310	49	MTN6903-6214	59	MTN619744	68	MTN644492	83
MTN6003-0005	169	MTN6260-0315	50	MTN6903-6219	59	MTN625114	67	MTN644592	83
MTN6003-0006		MTN6260-0410	46	MTN6903-6260	59	MTN625160	67	MTN644692	85
	142, 170	MTN6260-0415	47	MTN6903-6300	58	MTN625199	67	MTN644792	84
MTN6005-0001	104	MTN6270-0000	56,	MTN6903-6301	58	MTN625214	68	MTN644892	84
MTN6010-6534	74		62, 71	MTN6904-0001	105	MTN625260	68	MTN644992	85
MTN6010-6535	74	MTN6270-0010	60	MTN6904-0002	105	MTN625299	69	MTN645094	167
MTN6010-6536	74	MTN6270-0011	71	MTN6921-0001	167	MTN625414	67	MTN646704	139
MTN6180-0319	60	MTN6270-0015	74	MTN296019	35	MTN625460	67	MTN646808	127
MTN6180-0325	60	MTN6270-4060	52	MTN296025	35	MTN625514	67	MTN646991	152
MTN6180-0414	60	MTN6270-4160	53	MTN296044	35	MTN625560	67	MTN647091	151
MTN6180-0460	60	MTN6270-4260	53	MTN297914	35	MTN625614	68	MTN647393	122
MTN6180-6033	70	MTN6270-5001	51	MTN297960	35	MTN625660	68	MTN647395	123
MTN6180-6034	70	MTN6270-5004	51	MTN550619	102	MTN625714	68	MTN647593	125
MTN6180-6035	70	MTN6270-5005	51	MTN616719	161	MTN625760	68	MTN647595	126
MTN6180-6036	70	MTN6270-5006	52	MTN616725	161	MTN625814	68	MTN647893	129

MTN647895	130
MTN648493	132
MTN648495	133
MTN648704	138
MTN649202	121
MTN649204	124
MTN649208	127
MTN649212	131
MTN649310	149
MTN649315	148
MTN649350	148
MTN649704	139
MTN649802	138
MTN649804	140
MTN649808	140
MTN649908	136
MTN649912	137
MTN663529	173
MTN663591	107
MTN663592	107
MTN663593	109
MTN663594	109
MTN663595	108
MTN663596	108
MTN663692	107
MTN663991	104
MTN668091	112
MTN668990	29
MTN668991	29
MTN670802	82
MTN670804	82
MTN676090	32
MTN677290	112
MTN680204	30
MTN680329	30
MTN681799	35
MTN681829	35
MTN682191	109
MTN682291	156
MTN682991	106
MTN683832	27
MTN683890	28
MTN683901	29
MTN684032	27
MTN684064	28
MTN689701	31
MTN689702	31
MTN693003	173
NU553018	76
NU553020	76
NU553030	76
NU553054	76
NU553118	76
NU553120	76
NU553130	76
NU553154	76

* Make the most of your energy

Schneider Electric Industries SAS
35 rue Joseph Monier
92500 Rueil-Malmaison
France
www.schneider-electric.com

As standards, specifications and designs change from time to time, please ask for confirmation of the information given in this publication.



*This document has been printed
on ecological paper*

Publishing: Schneider Electric Industries SAS
Design: Breitbanddesign AG
Illustrations: Breitbanddesign AG
Photos: Constantin Meyer Photographie, Divis
Photo location: Office Kassel & Residential Cologne, Germany
Printing: